

Smart Ration Card and Automatic Ration Material Distribution System Using IOT

Sneha Ingale¹, Payal Paigude², Sneha Gaikwad³, Reshama Ade⁴, Prof. Rupali.M.Dalvi⁵

^{1, 2, 3, 4} Student's, Department of Computer Engineering, MMCOE, Karve-Nagar, Pune, India.

⁵ Professor, Department of Computer Engineering, MMCOE, Karve-Nagar, Pune, India.

Abstract: An accurate, automated and efficient RFID based technology used for distribution of ration using AADHAR card number which is an advanced methodology in PDS. PDS is also called as ration distribution system, which is one of the commonly disputable issue which is involved in malpractices. The on-going ration distribution system is having corruption in high level such as material theft, large waiting time and inaccurate measurement of goods in ration shop. Also to handle crowd is not easy while distribution of ration.

In this paper we are replacing the manual work done in the distribution centers by smart measuring automated electronic device with the help of ARM microcontroller which measures the goods accurately and updates it in data base periodically about the availability of goods and information regarding the transactions done in a digitalized manner. Here, to have access to the information and data regarding the stock a main data base is created which can be access by the government main stream invigilators for distribution centers from their head office. Therefore, this paper ensures corruption free ration centers working system which will also enhance the direct communication of the consumers with the government and will defiantly provide transparency.

Keywords: Embedded System, IOT, RFID, MYSql, Eclipse.

I. INTRODUCTION

RFID based programmed rationing shop is novel approach out in the PDS valuable for more effective, precise and mechanized method of distribution of ration. The present PDS framework has disadvantages like low processing speed, imprecise quantity of goods, material theft, large waiting time in rationing shop. The proposed rationing system replaces the manual work in the existing rationing shop. The main goal of the proposed system is automatic distribution of ration to give straightforwardness.

The proposed automated rationing system depends on RFID innovation that replaces regular ration cards. RFID tag is given rather than ration cards. Customer's database is already saved in microcontroller which is given by Government Authority. Customer has to scan the RFID tag to RFID card reader and after that microcontroller checks detail of customer which are stored already in the system to distribute material in rationing shop. After effective check, customer has enter material type and also amount of material with the help keypad. In the wake of conveying appropriate material to customer, the microcontroller sends that data to consumer.

Each customer has provided a RFID tag which goes about as the ration card. This RFID tag has all the data of the customer, required for taking the ration in required quantity from the rationing shops. The customer needs to demonstrate this RFID tag to the RFID reader, which is connected to a microcontroller, which peruses the data in the tag and in like manner instruct the consumer to give required amount of ration to the card holder.

II. MOTIVATION

Civil Supply distribution system in today's scenario faces loads of challenges as lots of controversial issues like illegal smuggling of goods, corruption and adulterations in goods happens here in the distribution centers in both rural and urban parts of India. Now a day's IOT is an emerging technology. So with the help of IOT and embedded system PDS can be directly connect the consumer to government to solve the issue of corruption in ration distribution centers.

III. GOALS AND OBJECTIVES

A. Goals

- 1) Main goal of this framework is to reduce corruption.
- 2) Proper ration distribution.
- 3) Transparency.

IV.OBJECTIVES

- 1) Planned approach towards working
- 2) Accuracy.
- 3) Immediate Upgradation of data in the system.
- 4) To design user friendly system.

V.LITERATURE REVIEW

[1] Civil Supply distribution system in today's scenario faces loads of challenges as lots of controversial issues like illegal smuggling of goods, corruption and adulterations in goods happens here in the distribution centers in both rural and urban parts of India. These controversies include irregular measurement of the goods, wrong entries in the manual stock register of centers containing wrong stock information of the commodities that are supplied or delivered to the consumers, other times the actual goods provided by the government for distribution does not reach the common people effectively as the information or data regarding the goods received by the ration centers and their availability in the centers for distribution can be altered by the workers of the ration centers which cannot be noted or recognized by the consumers as they have no access to the manual record of data. In our project we have replaced the manual work done in the distribution centers by smart measuring automated electronic device with the help of Arduino microcontroller which measures the goods accurately and updates it in data base periodically about the availability of goods and information regarding the transactions done in a digitalized manner.

Here, to have access to the information and data regarding the stock a main data base is created which can be access by both common consumers of that particular locality and by the government main stream invigilators for distribution centers from their head office. Therefore, this project ensures corruption free ration centers working system which will also enhance the direct communication of the consumers with the government and will defiantly provide transparency. [2] In the present days many immoral activities are taking place in ration shops, which are meant to distribute the commodities to the people who are in below the poverty line, as the distribution process is manually operated and due to which it consumes a lots of time.

To overcome this problem we one can use RFID technology. In this paper RFID tags are introduced, The RFID cards are instead of ration cards, which consist of all the details about the card holder like family details, type of card and its validity etc. In this paper we are going to discuss different types of automatic ration distribution system implemented for the automatic ration distribution. [3] The Government of India in an effort to ensure fair supply of food items under PDS to the targeted underprivileged sections as per the eligibility fixed by the Government of India.

In spite of the best efforts by Government officials at various levels, there are a few bottle-necks and inconveniences to the targeted citizens in availing the services provided. All these happen because every job in the ration shop involves manual work. Because of intervention of manual work there are lots of illegal activity occurs. As solution to this problem the proposed system proposes a transparent and highly scalable Ration Distribution (Food Distribution) system with biometric authentication. The conventional paper based ration card is replaced by smart card. The system is placed at each ration shop which is connected to the server through web. Every time before ration collection each user has to login into the system. The user need not to pay the cash money as the appropriate balance is deducted from users bank account, so there is no direct involvement of ration shop owner in transaction. The transaction details are send to users mobile

The government can have overall control and monitoring at each ration shop through web. In addition user as well as ration distributor will get SMS based alert about arrival of commodities. As a result, this new e-PDS system can reduce possible human errors and provide accurate information of public distribution system at any point. [4] The Rationing distribution system also called public distribution system distributes food items to the poor. Major commodities include rice, wheat, sugar and kerosene. In this system QR codes will be provided instead of current ration cards. Users database is stored which is provided by Government. The Smart Card must be scanned by the customer to show the details of items allocated by government, and then it checks customer details with stored data to distribute material in ration shop. Biometric i.e. Fingerprint scanning will be done for security and authentication purpose.

VI.PROBLEM STATEMENT

There is a lack of transparency between the dealer and consumer. Due to this problem of dealer the poor people do not get the items as stated on their ration card. Moreover, there is no complaint system through which the consumer's interests can be protected. So to avoid all these problems we are going to design a smart rationing system in which RFID will act as ration card of customer in which the data of that particular card holder is saved in the database.

VII. SYSTEM ARCHITECTURE

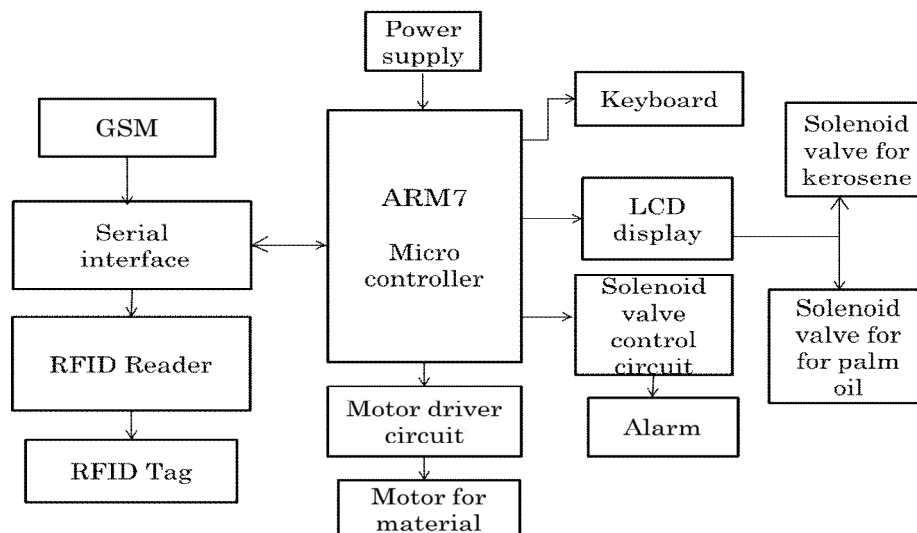

Fig1. System Architecture

- A. ARM7 microcontroller: This is main module through which all input and output processing is going to happen
- B. GSM module: This module is used for sending SMS to the user about delivered ration
- C. LCD Display: LCD is used for displaying related activities and remaining ration stock
- D. Keyboard: It is acts as a input to the system.
- E. RFID Reader: RFID Reader is used for reading RFID tag and transmits the information to the microcontroller.
- F. RFID Tag: RFID tag which is used acts smart ration card and when it is swapped by customer it shows all related data.
- G. Solenoid value control circuit: A level sensor is a device for determining the level or amount of liquids, fluids or other material that flow in a closed or open system.

VIII. CONCLUSION

The proposed framework is for the benefit of government as well as common people. The proposed system will find its application in the rationing shops which are run by government. Also, this project includes an electronic device which can be used in the distribution centers and rationing shops.

REFERENCES

- [1] M. Pallikonda Rajesekaran, R. Arthi, D. Balaji, P. Daniel "Automatic smart ration distribution system for prevention of civil supplies hoarding in India" Advanced Computing and Communication Systems (ICACCS), 2017 4th International Conference on 6-7 Jan. 2017, 10.1109/ICACCS.2017.8014593
- [2] Swapnil R. Kurkute, Chetan Medhe, Ashlesha Revgade, Ashwini Kshirsagar "Automatic ration distribution system — A review" Computing for Sustainable Global Development (INDIACom), 2016 3rd International Conference on 16-18 March 2016.
- [3] Sana A. Qader Perampalli, Dr. R.R. Dube "Smart Card based e-Public Distribution System" International Journal of Advanced Research in Computer and Communication Engineering Vol. 5, Issue 5, May 2016.
- [4] Golden Bagul , Brendon Desouza, Tejaswini Gaikwad , Ankush Panghanti, Trupti Kumbhare "A Survey on Smart Ration Card System" nternational Journal Of Engineering And Computer Science ISSN: 2319-7242, Volume 6 Issue 1 Jan. 2017, Page No. 20096-20098, DOI:10.18535/ijecs/v6i1.42