

Waste Segregation Using Machine Learning

Yesha Desai¹, Asmita Dalvi², Pruthviraj Jadhav³, Abhilasha Baphna⁴

^{1, 2, 3, 4} Department of Computer Engineering, St. John College of Engineering and Management, University Of Mumbai

Abstract: *The present Indian government has started different projects for advancing sanitation and neatness. Megacities in India, for example, Ahmedabad, Hyderabad, Bangalore, Chennai, Kolkata, Delhi and more noteworthy Mumbai have dynamic monetary development and high wastage per capita. Scratch issues and difficulties such as absence of gathering and isolation at source, shortage of land, dumping of e-Waste, and so on. The present waste accumulation framework assembles a wide range of waste in an unsorted way by utilizing physical work. The isolation of this waste is exceptionally repetitive, tedious and wasteful undertaking, which is numerous a period dangerous to the soundness of the specialists. Subsequently, there is requirement for a framework, which robotizes the procedure of waste isolation, with the goal that the junk transfer can be executed effectively and productively. The proposed framework utilizes machine learning strategies such as, CNN to accurately characterize the loss into degradable and non-degradable. The grouped waste can be isolated into different classifications utilizing a flap. The computerized order subsequently helps during the time spent for sanitation. The ordered waste can be additionally arranged and concurring handled by the businesses. This influences the computerized transfer framework to work quickly and productively. This model can be scaled up to a modern level with the goal that it can be utilized as a part of semi-urban and urban territories.*

Keywords: *Waste, Waste Segregation, Machine Learning, Convolutional Neural Network (CNN), degradable, non-degradable, Raspberry Pi*

I. INTRODUCTION

The system depends on Machine learning domain and it is to make an entire self-ruling isolation system in semi urban and urban regions. The field of machine learning is worried about the subject of how to develop computer programs that consequently enhance with involvement. Lately numerous effective machine-learning applications have been created, going from information mining programs that figure out how to distinguish deceitful charge card exchanges, to data separating frameworks that take in clients' perusing inclinations, to automatic vehicles that figure out how to drive on open interstates.

Waste arranging can happen physically at the family and gathered through some accumulation plans, or consequently isolated by mechanical natural treatment frameworks. Waste segregating is the procedure by which waste is isolated into various components. Waste isolation implies separating waste into dry and wet. Dry waste incorporates wood and related items, metals and glass. Wet waste, commonly alludes to natural waste for the most part produced by eating foundations and are overwhelming in weight because of soggy. Waste can likewise be isolated on premise of biodegradable or non-biodegradable waste.

Waste is gathered at its source in every zone and isolated. Populace blast, combined with enhanced way of life of individuals, brings about expanded age of strong squanders in urban and also rustic regions of the nation. In India like every single other division there is a stamped qualification between the strong waste from urban and country zones. In [4] CNN innovation is utilized to order the protest from the identified articles gathered from the movement identifier. This paper portrays computer vision and example acknowledgment procedure utilizing the descriptor and the correlation with the picture acknowledgment by utilizing profound learning. "Automatic Garbage Collector Robot Model" [5] this exploration paper plans to outline and make AGATOR (Automatic Garbage Collector), a rotor robot display as programmed city worker to counter aggregation of junk in the stream which has no stream viably and proficiently. Two popular learning algorithms are used namely deep learning using CNN and support vector machines (SVM) [7]. Convolution Neural Networks [4] have had a great impact on pattern recognition.

The proposed idea is to create an autonomous system which segregates the waste. The system segregates the waste using CNN algorithm in machine learning. The algorithm detects and classifies the waste according to the dataset provided to CNN. The algorithm accordingly classifies the waste as biodegradable and non-biodegradable. As mentioned in [1] the given system uses microcontroller and sensors to segregate the waste directly where as we look forward to firstly classify the waste and reduce the use of bigger hardware components. The result is then processed to the hardware components of the system where raspberry pi is being used to dump the waste in the bins.

II. LITERATURE REVIEW

A. Microcontroller Based Automatic Waste Segregator[1]

The expanding populace of India postures genuine dangers with respect to the accessibility of living space, usage of common assets and crude materials, training and business. In any case, another difficult issue is expanding measure of waste created every moment by a person. Answer for this issue could be isolating the loss at the transfer level itself.

This technical paper proposes a programmed waste segregator that goes for isolating the waste naturally at the transfer level. In this manner, there is no need of work to work for overseeing and transfer of waste.

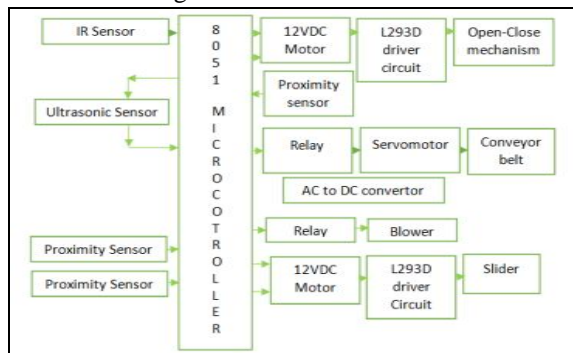

Fig. 1 Block diagram for Microcontroller Based Automatic Waste Segregator

Fig. 1 shows a basic 8051 microcontroller frames the core of the framework. It controls the working and timing of all the sub areas to sort the loss into the three essential classifications. It is intended to sort the loss into three noteworthy classes, to be specific metallic, wet and dry, in this manner making waste administration more compelling. Another way of separating waste is reported in [6]. The method works on separating the incoming waste in different containers using multimedia embedded processor, image processing, and machine learning.

B. Object Detection and Recognition System Using Artificial Neural Networks and Drones [2]:

This research paper describes the digital image object detection and recognition system using artificial neural networks and drones. This paper portrays the structure of the framework and segments of the learning sub-framework and the preparing sub-framework (identification, acknowledgment). The learning sub-framework is a product stage comprising of two applications. The primary application is utilized for generation patterns required for learning process, while the second application depends on designs made in program and static examples arranged independently instructs our framework distinguishing and perceiving asked for objects. The main advantage is that artificial methods and Machine Learning increases the system efficiency, so there is no need of algorithms and rules by programmer for system implementation. With the help of base data and object types, object can be classified more accurately.

C. Deep Feature Extraction and Classification of Hyperspectral Images Based on Convolutional Neural Networks [3]

The paper portrays hyperspectral picture grouping utilizing convolutional neural systems. Hyperspectral pictures are normally made out of a few many several information channel of a similar scene. The profound features of HIS's are nonlinear, discriminant, and invariant. These features are valuable for picture classification and target recognition. For the arrangement of HSI, there is a typical issue of irregularity between high dimensionality and constrained accessibility of preparing tests. A couple of techniques, for example, L2 regularization and dropout are explored to abstain from overfitting in class information displaying in this paper. The paper gives itemized data of unearthly which are given by hyperspectral sensors increments.

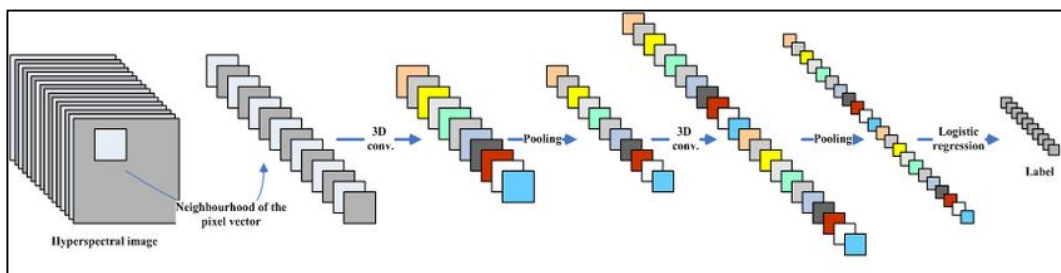

Fig. 2 Architecture diagram for deep CNN with spectral FE of HIS

III. PROPOSED IDEA

The proposed system concentrates on identification, classification and segregation of waste. The waste, which is in unsorted manner, is dumped in a landfill, which further creates hazardous health problems. The proposed system aims to recognize and categorize the waste autonomously, which require minimal human intervention. This entire process of recognition of waste material is based on the shape and size of the objects. The system will be trained through datasets by using machine learning technique such as Convolutional Neural Network (CNN). Utilizing Raspberry Pi the characterization result will be given to the equipment part of the framework with the goal that it will be dumped in its separate containers. The system will order waste automatically and isolate it so the physical work will be diminished. It can be castoff in large scale industries for waste management purpose.

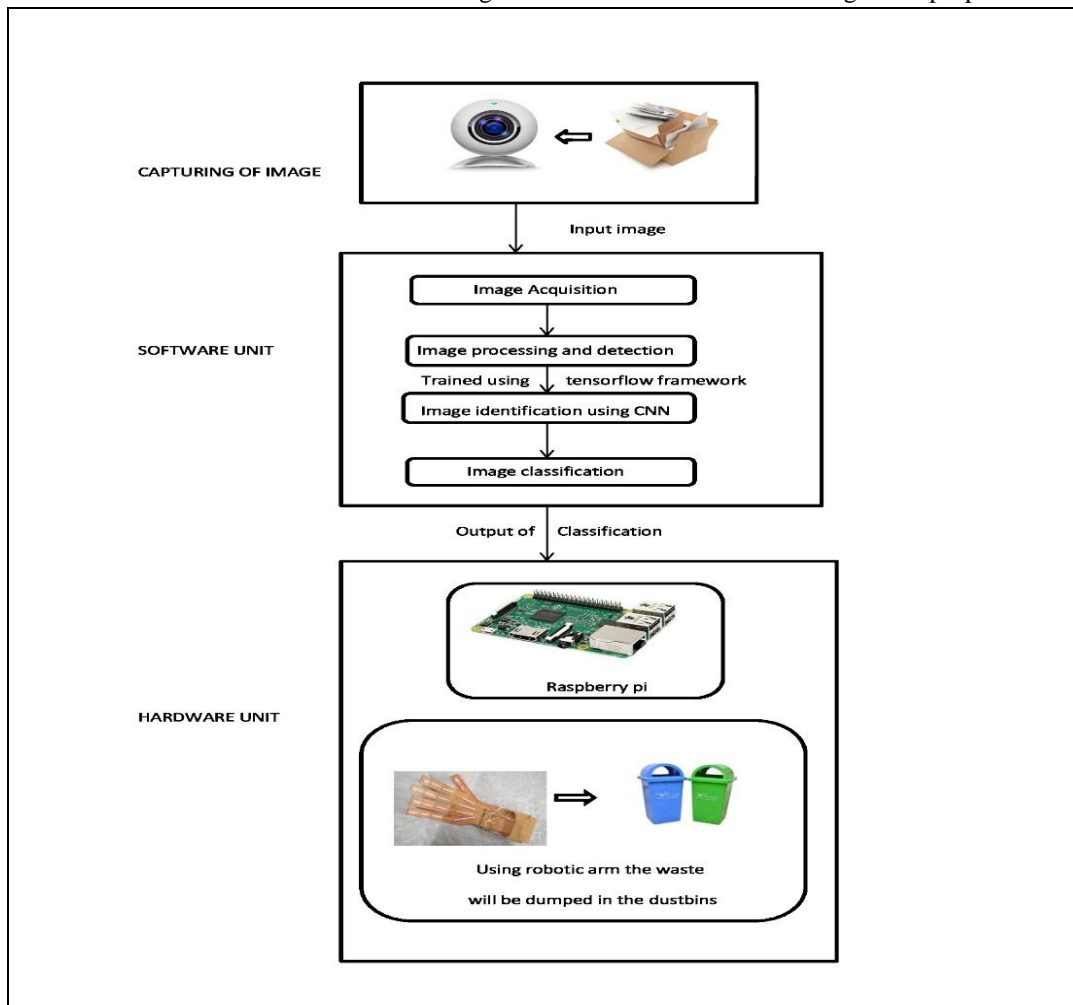

Fig. 3 Architecture diagram for Waste Segregation

A. Software Unit

The first stage is image acquisition stage. It catches image from camera with the goal that it can be passed for handling and recognition of picture. After picture has been saved, different strategies for handling can be connected to the picture to perform a wide range of vision undertakings. After analysing, the image is processed and detected. The system is trained using Tensor flow framework. By relying on large datasets, the framework can recognize the picture and plan significant labels and classifications. The trained data is used to classify the waste into two categories namely degradable and non-degradable.

B. Hardware Unit

Input from camera is given to the raspberry pi module. This captured image then will be the main source of data for our system. The Raspberry Pi is a progression of little single-board PCs created in the United Kingdom by the Raspberry Pi Foundation to advance the educating of essential software engineering in schools and in creating nations. The Raspberry Pi Camera Module v2 is a high quality 5 megapixel. It is the backend process for classifying the images and to sort the waste autonomously.

IV. IMPLEMENTATION

The first step is to train the images (data) after collection of the dataset. To obtain the accurate results, training of the dataset is very vital. A very large number of images are given as an input to train the dataset.

A. Working of System to recognise and detect the images,

- 1) Place the waste object in front of camera.
- 2) The camera will capture the image and it will transmit to the system.
- 3) The system will identify the object using Tensor Flow.
- 4) Further the object will be detected and classified using CNN algorithm. Thus, CNN will result the waste as degradable or non-degradable waste.
- 5) CNN will detect the waste and take the input as an array of pixel values.
- 6) The pixel values of image will be multiplied with the filter values.
- 7) The multiplication will be summed and the entire procedure will be repeated for the whole image.
- 8) Further max pooling will get an output, which has the maximum value in particular, window by reducing the parameters and generalizes the convolutional layer.
- 9) It then determines the features which most correlates to a particular class (dataset). Thus, the waste will be classified.
- 10) The result of classification will remain in Raspberry Pi.
- 11) Raspberry Pi will be programmed so that it instructs the motor and flap to dump the classified waste into the respective bins.

V. METHODOLOGY

A Convolutional Neural Network (CNN or ConvNet) is a class of deep, feed-forward ANN that has been applied to analyse visual imagery. Natural procedures in which the availability design between neurons is motivated by the association of the creature visual cortex enlivened convolutional systems.

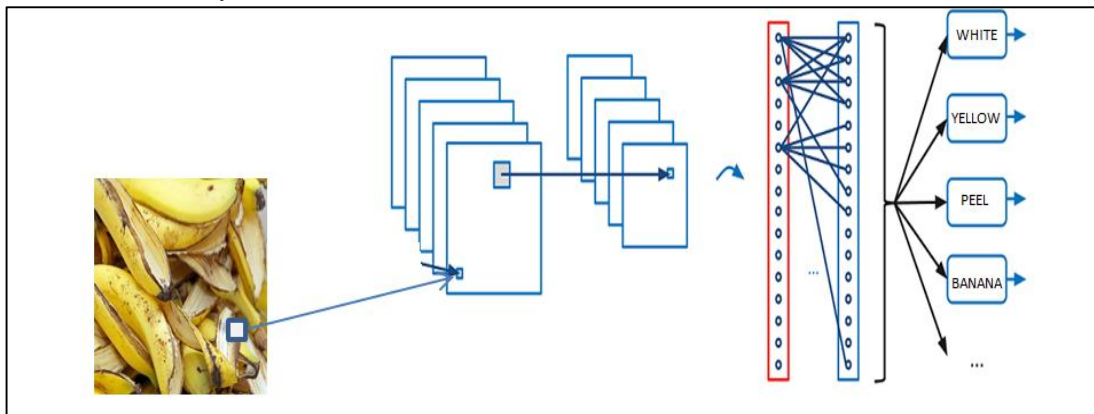

Fig. 4 CNN Architecture

CNN works on three layers

A. Layer 1: Convolutional Layer

- 1) Step 1: It takes an input as an array of pixel values
- 2) Step 2: Convolutional layer contains filter, weights, or parameters that convolutes around the input image
- 3) Step 3: As the filter is convoluting it multiplies the values in the filter with original pixel value of image.
- 4) Step 4: The multiplications are summed. This is repeated for the entire image.

The remaining array of numbers is called an activation map or feature map.

After multiplying if we get a large value then there is an area/ pixel present in the image and if we get 0 (zero) then there is no image.

B. Layer 2: Max-pooling

Max-pooling is the application of a moving window across a 2D input space, where the maximum value within that window is the input.

It does the two main things:

It reduces the number of parameters within the model (down sampling).

It generalizes the result from a convolutional filter.

C. Layer 3: Fully-connected Layer

Fully-connected layer is completely associated interface where each neuron in one layer is connected to each neuron in another layer.

Step 1: It takes an input volume which is an output from max-pooling layer.

Step 2: It determines which features most correlate to a particular class.

Step 3: It then computes the products between the weights and the previous layer to get correct probabilities for different classes

VI. CONCLUSION

This system isolates waste automatically utilizing no sensors, however the energy of machine figuring out how to perceive as to which waste can be arranged as degradable or non-degradable. As the system works independently, there is no need of human mediation to control or to do any dreary assignment from this time forward. The system is limited to the objects which look like metals but are not metals. In future, the system can be upgraded to the better detection of waste by using advanced algorithms of machine learning.

REFERENCES

- [1] International journal of innovative research in electrical, electronics, instrumentation and control engineering vol. 3, issue 5, may 2015 copyright to IJIREICE DOI 10.17148/ijireice.2015.3529 104 "Microcontroller Based Automatic Waste Segregator" M.K.Pushpa1, Aayushi Gupta2, Shariq Mohammed Shaikh3, Stuti Jha4, Suchitra V5.
- [2] "Objects detection and recognition system using artificial neural networks and drones", Dymitr Pietrow, MSc Military University of Technology, Jan Matuszewski, PhD Military University of Technology.
- [3] IEEE Transactions on Geoscience And Remote Sensing, Vol. 54, No. 10, October 2016, "Deep Feature Extraction and Classification of Hyperspectral Images Based on Convolutional Neural Networks", Yushi Chen, Member, IEEE, Hanlu Jiang, ChunyangLi, Xiuping Jia, Senior Member, IEEE, and Pedram Ghamisi, Member, IEEE.
- [4] "Object Classification using CNN for Video Traffic Detection System", Hyeok Jang, Hun-Jun Yang, Dong-Seok Jeong Dept. of Electronic Engineering Inha University Incheon, Hun Lee Laboratory of HuNS Inc. Anyang, Korea.
- [5] International Journal of Future Computer and Communication, Vol. 3, No. 5, October 2014 "Automatic Garbage Collector Robot Model", Osiany Nurlansa, Dewi Anisa Istiqomah, and Mahendra Astu Sanggaha Pawitra, Member, IACSIT.
- [6] Jesuit University of Guadalajara, Department of Electronics, Systems and IT(ITESO), Mexico, Computacion y Sistemas, Vol. 19, No. 3, 2015, pp. 487-500 Doi: 10.13053/CyS-19-3-2254 "Intelligent Waste Separator", Andres Torres-Garcia, Oscar Rodea-Aragon, Omar Longoria-Gandara, Francisco Sanchez-Garcia, Luis Enrique Gonzalez-Jimenez.
- [7] 2016 IEEE International Multidisciplinary Conference on Engineering Technology (IMCET), 978-1-5090-5281-3/16/\$31.00 ©2016 IEEE "Comparing Deep Learning And Support Vector Machines for Autonomous Waste Sorting", George E. Sakr, Maria Mokbel, Ahmad Darwich.