



Digital Walkie-Talkie

Kakad Pallavi Changdeo¹, Pansare Pooja Khandu², Sawai Priti Kakasaheb³, Handore Kanchan Gorakh⁴, Dr. K T V Reddy⁵

^{1, 2, 3, 4} Students of Electronics & Telecommunication, Sir Visvesvaraya Institute of Technology, Maharashtra, India

⁵Principal, Sir Visvesvaraya Institute of Technology, Maharashtra, India

Abstract: *Today multimedia with its wide variety of applications has become a part of human life. The buffering time required is more. The proposed system eliminates this drawback of all the existing video streamer. The study of the methods existing in the present scenario for detection of motion and faces using various algorithms and discuss about their area of application by implementing with the help of on the on-board miniature Raspberry Pi. The proposed Audio/Video streaming system provides a platform independent, secure and low bandwidth solution. Open CV functions are optimized to the specific platform and can be further used as a surveillance system which is embedded on the computer.*

Keywords: *Walkie-Talkie, Raspberry Pi Zero, USB Camera, Open CV, Wi-Fi*

I. INTRODUCTION

In the past decade, the need for security has been increased for various reasons. The next evolution of security cameras is to annotate video and local coordinates of the objects that are tracked by multiplexing many video streams together in real-time. Video surveillance is playing a vital role in maintaining security in privately or socially like banking, in house monitoring, finance etc. This can be easily monitored by using our regular personal computer. Over the years back all of us have used analog cameras that are connected to coaxial cables. As the years passed to improve the performance and increase the compatibility of the user we have switched to digital systems, now to IP- based systems. In practice it is not easy to detect and track any moving object. The Omni directional cameras are generally used for this purpose. Mobile cameras can also be used for this purpose. The recorded video data captured is collected and compressed into MPEG format then transferred to the network. This signal is processed by the client monitoring the system; it will reframe, restructure and recompose the video images. Using a coaxial cable cost more than this wireless video monitoring system. A digital radio operates in digital mode, which means they use a mathematic system represented by binary numbers 1 or 0 to transmit the voice. The voice transmitted through digital two ways radio is very clear. It can recognize background noises such as wind, rain, manufacturing noise, traffic, etc. and exclude it from the spoken words. Therefore, digital walkie talkies are perfect for use in noisy areas or outside in windy conditions. Digital two way radio offers a clear and consistent coverage up to the edge of transmissions without the 'break ups' in transmissions which is often received with analogue radios when coming to their coverage boundary. Various advanced applications are available with digital radios. For instance, GPS services which can locate the radio users are widely popular as these radios allow voice, data, and tracking on the same network at the same time, meaning supervisors can monitor staff movements at all times. This is particularly useful for Hospitality, Events and personal security. After trying out some smartphone apps and mobile radio, I decided to build my own based on Raspberry Pi Zero.

The primary Goal of this project is to use Wi-Fi-Direct and Audio/Video real-time recording/playing to setup a communication between android devices which are in the same group frequency ID. Therefore, our Walkie-Talkie architecture has to handle Wi-Fi-Direct communication, Audio/Video Recorder/Player and Group Frequency Exchanging/Maintenance.

II. PROPOSED WORK

As the RPI booted successfully and launching to the application. It will start communication with near-by device which are linked through network or hosted network. The booting process it somewhat take delay to launching the launcher .sh as the kernel of system loaded successfully. It reaches to the application and turn auto-start the application launcher.sh is the shell execution file which is designated in the kernel shell scripting. As the application start successfully it will automatically started the chromium API for accessing camera and microphone. While the start-up generatively it will automatically enables the camera and microphone module. As the application Jitter Si launch successfully. It will ask for the Rom number or show another link to access the system or mobile device. We can be done through it via smartphone application (Skype). It is available on Google play/plugin start. It is also asking for the communication mute like mute camera as well as voice.

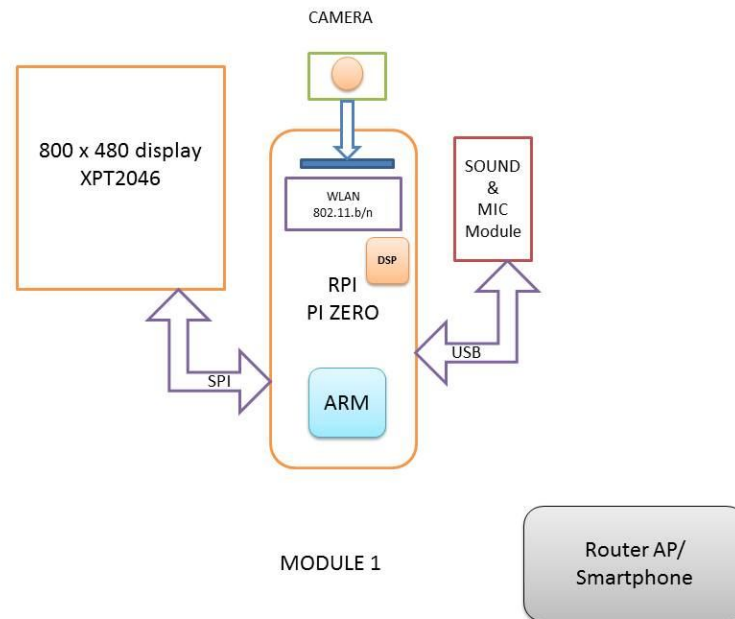

Fig. 1 Block Diagram of Digital Walkie-Talkie

A. Raspberry Pi Zero

It will get a fully working 32-bit CPU with a 1GHz ARMv6 single core microprocessor (ARM1176), a VideoCore 4 GPU, and 512MB of memory. The GPU is capable of driving a full HD display at 60 fps. As well as the SoC and RAM you also get access to the 40 General Purpose Input and Output (GPIO) ports. It supports Linux operating system. It consists of in-built SPI, I2C, Camera interface (CSI). Two micro-USB ports, one for power and the other for data. Because of its size and use of an energy-efficient ARM-based processor, the Raspberry Pi Zero can be powered from an external battery pack, like the ones you use to charge your mobile phone on the go, with low power consumption.

B. PI Camera

Pi Camera module is a camera which can be used to take pictures and high definition video. Raspberry Pi Board has CSI (Camera Serial Interface) interface to which we can attach Pi Camera module directly. This Pi Camera module can attach to the Raspberry Pi's CSI port using 15-pin ribbon cable.

Features of Pi Camera Here, we have used Pi camera v1.3.

Resolution - 5 MP HD

Video recording - 1080p @30fps, 720p @60fps, 960p @45fps and so on

It can capture wide, still and dynamic.

Images of resolution 2592x1944 pixels

C. TFT Touchscreen Display

The 3.5" resistive touch screen with 480 x 320 resolution will certainly meet your needs. If further combined with a wireless keyboard, it will act as a fully functional computer that fits right in your pocket. Use it to run the Pi's terminal, to play games, or to browse the web.

Some technical specification

Operating Voltage: 5V,	Screen resolution: 480 x 320,	Interface: SPI, GPIO
Header Pins: 16,	UART Header Pins: 1,	Gravity I2C Pins: 1,
Gravity UART Pins: 1,	Dimensions: 86 x 56 mm / 3.38" x 2.24",	Weight: 70g.



D. Headset Module

A radio frequency identification reader (RFID reader) is a device used to gather information from an RFID tag, which is used to track individual objects. Radio waves are used to transfer data from the tag to a reader. The tags contain electronically-stored information. Passive tags collect energy from a nearby RFID reader's interrogating radio waves. RFID systems can be classified by the type of tag and reader. A Passive Reader Active Tag (PRAT) system has a passive reader which only receives radio signals from active tags (battery operated, transmit only). RFID is a technology similar in theory to bar codes. However, the RFID tag does not have to be scanned directly, nor does it require line-of-sight to a reader. The RFID tag it must be within the range of an RFID reader, which ranges from 3 to 300 feet, in order to be read. RFID technology allows several items to be quickly scanned and enables fast identification of a particular product, even when it is surrounded by several other items.

III. ADVANTAGES, APPLICATIONS & FUTURE SCOPE

A. Advantages

- 1) The biggest advantage of automation along with platform doors is security.
- 2) Digital radios offer clearer voice quality.
- 3) Because the signal is digitized, digital error correction will result in a clearer voice coming out of the receiving radio.
- 4) Digital radios offer new functionality such as gps tracking, complex calls groups, individual calling etc.
- 5) Digital radio communications are more secure.
- 6) Improved call clarity.
- 7) Increased encryption.
- 8) Increased coverage.

B. Applications

- 1) It having the multipurpose and multitasking features like it can be used for sending various data like pitures, video-streams as well as text files through the network by chanding some user applications.
- 2) It can useful for the defense and millitary applications aswell as surveillance.
- 3) It is used for e-learning process as well as digital classrooms.
- 4) It's most basic application is meeting in the offices as well as workshops.

C. Future Scope

- 1) This project can be enhanced further in following ways. As this project has a limitation of distance, which can be overcome by creating the wireless access points as raspberry pi zero has inbuilt Wi-Fi which makes the work easier.
- 2) Another ways this project can be enhanced by making the Pi online that is once Pi is made online we can easily operate it from anywhere in the world which can be done by PORT forwarding technique Be run and operating costs of the system to be kept pretty low.

IV. CONCLUSIONS

Communication is the important part of daily routine in now days. In this project we are creating the client video-conferencing devices using Raspberry Pi zero board. It is streaming the video frames with audio. The frames are capturing though via network by using IP and SSID which automatically generated through the socket. The project has been successfully done with a designed embedded real-time video monitoring system. Linux operating system is used for streaming purpose. It is available at portable, low cost, easy to use and maintain. It can easily be upgraded to any high end application. Here the web browser is based on MJPG streamer for streaming captured video from camera placed in remote location. The MJPG streamer is cross-compiled and loaded in to the Raspberry pi board to act as a web streaming server. The regularly captured videos are transmitted to the server and these are being processed to obtain the actual data whenever it is needed.

V. ACKNOWLEDGMENT

It is our immense pleasure to work on the project Digital Walkie-Talkie. We take this opportunity to express deep gratitude and sincere thanks our Principal, **Dr.K T V Reddy** for giving us such an opportunity to develop practical knowledge about subject. We are greatly thankful to **Mr Ulhas V. Patil**, Head of Electronics and Telecommunication Engineering Department for his valuable encouragement at every phase of our seminar work and project. We are also grateful to the entire staff of Electronics and Telecommunication Engineering Department who directly or indirectly helped us in successful completion of seminar.



REFERENCES

- [1] Yong-ik Yoon, Jee-ae Chun, Tracking System for mobile user Based on CCTV. Information Networking (ICOIN), 2014 International Conference on, Phuket, 10-12 Feb. 2014, pp. 374-378.
- [2] Viren Pereira, VandykAmsdem Fernandes, Junieta Sequeira, Low Cost Object Sorting Robotic Arm using Raspberry Pi. Global HumanitarianTechnology Conference - South Asia Satellite (GHTC-SAS), 2014 IEEE, Trivandrum, 26-27 Sept. 2014, pp. 1-6.
- [3] KavithaMamindla, Dr.V.Padmaja, CH.NagaDeepa, and "Embedded Real Time Video Monitoring System Using Arm", IOSR Journal of Engineering (IOSRJEN) Vol. 3, Issue 7 (July. 2013), ||V6 || Page(s) 14-18. 4
- [4] G. Senthikumar, S.Ragu, N. Siva Kumar, "Embedded Video Surveillance with Real time Monitoring on Web", International Journal of Mathematics Trends and Technology May to June Issue 2011 Page(s):46-49.
- [5] Yimamuaishan.Abudoulikemu, Yuanming Huang, Changqing, A Scalable Intelligent Service Model for Video Surveillance System Based on RTCP .Signal Processing Systems (ICSPS), 2010 2nd International Conferenceon (Volume:3), Dalian, 5-7 July 2010, V3-346 - V3-349
- [6] <http://hackaday.com/2017/03/26/turn-that-pi-zero-into-a-streaming-camera-step-by-step/>
- [7] <http://derekmolloy.ie/writing-a-linux-kernel-module-part-1-introduction/>
- [8] C. Bahlmann, Y. Zhu, Y. Ramesh, M. Pellkofer, T. Koehle, A system for traffic sign detection, tracking, and recognition using color, shape, and motion information. IEEE Intelligent Vehicles Symposium, Proceedings,2005, pp. 255-260. 9