



IJRASET

International Journal For Research in
Applied Science and Engineering Technology



INTERNATIONAL JOURNAL FOR RESEARCH

IN APPLIED SCIENCE & ENGINEERING TECHNOLOGY

Volume: 10 **Issue:** XII **Month of publication:** December 2022

DOI: <https://doi.org/10.22214/ijraset.2022.47803>

www.ijraset.com

Call:  08813907089

E-mail ID: ijraset@gmail.com

An Approach to Green Energy, Advantages and Its Application

Dr. Subhash Kumar Sharma, Dr. Shri Prakash Dubey

¹Assistant Professor, Department of Electronics, MGPG College, Gorakhpur

²Assistant Professor, Department of physics, MGPG College, Gorakhpur

Abstract: *We know that the Energy is the property of objects which can be converted into different forms or can be transferred to other objects but cannot be created or destroyed. Green energy is the energy that is produced in such a way as to minimize its negative impact on the environment. It is a renewable source of energy. Sources of green energy such as solar, wind, geothermal and hydro energy are developed and promoted as alternative source that make little or no contribution to climate change and the current application of this emerging technology, like generating electricity for various purposes, heating and cooling of water and more.*

Keywords: *Green Energy, different types of sources, advantages, applications*

I. INTRODUCTION

The idea of green energy is introduced in November 2006 as renewable energy standard offer program. That offer was in short called as SOP or RESOP. It introduced a 20 year feed in tariffs for hydro, wind, solar (PV) and biomass projects. The Ontario Green Energy Act (GEA), officially the Green Energy and Green Economy Act 2009 was introduced in the Ontario Legislature on February 23, 2009, to expand renewable energy production and encourage energy conservation[1]. The word 'Green' make our mind to think about a world without pollution and eco friendly. So the green energy reflects the idea about generation of energy from natural resources like sunlight, wind, rain, tides, plant, algae, geothermal heat, etc. having no or less impact on the environment and can be renewed.

These energy resources are renewable, meaning they're naturally replenished. There are two types of sources of energy in the world: renewable energy sources and non-renewable energy sources. Renewable energy sources are generated directly from nature for example, from the sun, rain, wind, tides, and it is possible to generate it over and over whenever it is needed. Renewable energy sources are abundant and are definitely the cleanest energy sources in Earth. Many types of Renewable energy sources are solar energy, biomass energy, wind energy, tidal energy, hydro energy, and geothermal energy. For instance, it is possible to use the energy from the sun and that is converted into electricity. Geothermal, wind, tides, and biomass energy from plants can also be used in different forms like Wind is harnessed from Earth's natural weather patterns. Hydropower comes from flowing rivers and from reservoirs. Solar energy comes from the Sun's light and radiation. Geothermal energy comes from the heat produced by the Earth underneath the ground.

The advantages of Renewable energy is that wind, sun, ocean, and geothermal energy is in abundance and completely free of charge. The renewable energy sources have very low or zero carbon emissions, so they are environmental friendly. The another advantage is, it is not necessary to rely on any country to supply renewable energy sources, unlike its non-renewable counterparts. Non-renewable sources are not environmental friendly and can have serious affect on our health. Most energy that is used in the world today is generated from non-renewable energy sources. These energy sources can be re-generated over a short period of time. Natural gas and oil are derived from ancient plant or animal remains or fossils. These remains are what we have been left with after millions of years of fluctuation in pressure and temperature. Non-renewable energy sources include oil, coal, natural gas, and nuclear energy. The advantage of non-renewable energy sources are it is ready, cheap, and easy to use. The non-renewable energy convert one non-renewable energy type to another.

The major disadvantage of non-renewable energy sources is that they are finite and will expire sometime in the future. This will make the prices of these non-renewable energy sources increase dramatically. They also cause severe environmental changes and are in a large way responsible for climate change and global warming. Non-renewable energy sources can have a serious impact on human health, as they are certainly not environmental friendly.

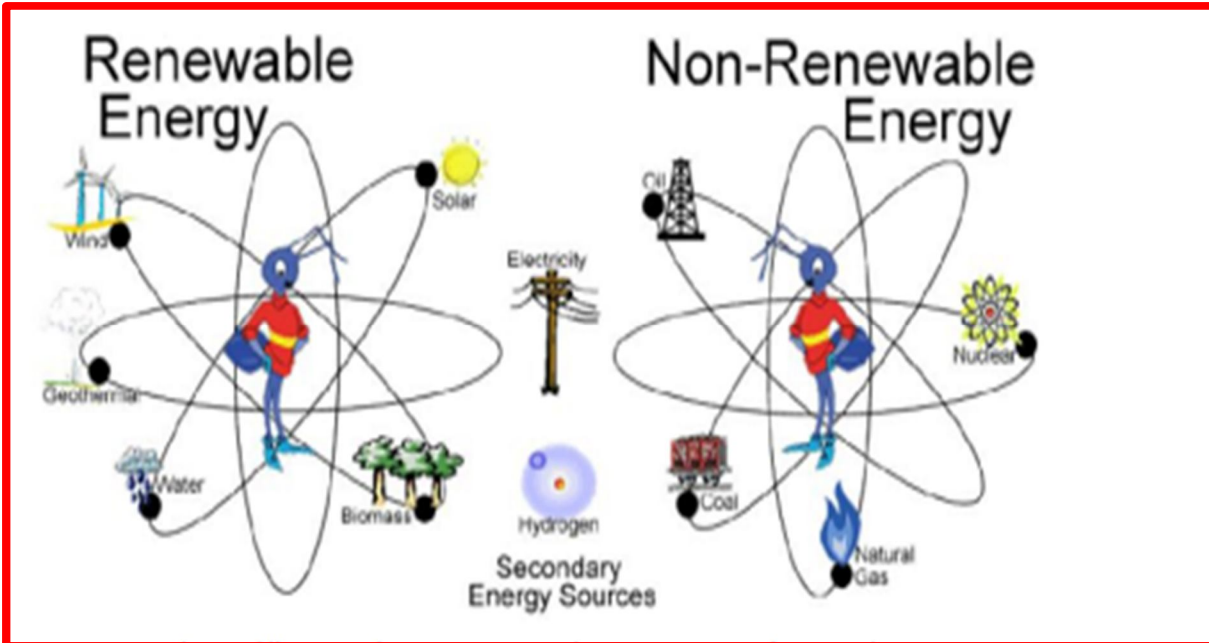

Fig(1) Diagram of Renewable and Non-Renewable Energy

Thus in this paper we discuss about different types of green energies, its advantages and applications.

II. GREEN ENERGY

Green energy comes from natural sources such as sunlight, wind, rain, tides, plants, algae and geothermal heat. These energy resources are renewable, meaning they're naturally replenished. The different types of renewable energy technologies include: Solar energy, Marine energy, Wind energy, Hydropower, Bio-energy, Geothermal energy etc.



Fig.2: Diagram of Green Energy

There are various renewable energy technologies, which include hybrid and related technologies. These are effectively used for: · Storing energy generated through renewable energy · For predicting renewable energy supply · Assisting in efficient delivery of energy generated by means of renewable energy technologies to energy consumers.

A. Concept

Our Traditional energy sources, such as fossil fuels have a big role in creating the effect of global warming and climate change to the earth and this makes us to create a subway to overcome these problems by introducing the concept of Green Energy. The primary goal of developing Green sources of energy is to generate power and also to minimize both waste and pollution, so that we can reduce the impact of energy production on environment. Scientist who favoured the use of green energy said that we can reduce the rate of climate change by using such sources. In contrast to fossil fuel sources these sources are renewable. The concept of Green Energy most oftenly considered when it comes to the issues such as cogeneration, heating and electricity. These sources can be purchased by the consumers or businesses as a means to support to support living which is environmental friendly, by reducing bad impacts of energy production. Today energy certificate or renewable energy certificate can be purchased to support the use of green practices. It is estimated that more than 35 million European homes and 1 million American homes are currently using Green Certificates that symbolizes their use of Green Energy. Ultimately, green energy is clean energy.

B. The Need Of Green Energy

Green energy is produced from renewable sources and produces very less impact on our environment. So, in order to protect Mother Nature from pollution and to ensure the supply of energy continuously we should start using green energy for industrial as well as domestic purpose.

To limiting global warming and protecting ecosystems by reducing CO₂ emissions through energy efficiency and renewable Energy, Green Energy Technology is essential. As temperatures rise, agricultural output will fall, damage from floods and storms will increase, (tropical) diseases will become more prevalent and access to water will become more of a problem for more and more people.

The cost to our environment is greater and loss is irreversible. The Earth's flora and fauna will suffer both directly from higher temperatures and indirectly through the damage to their habitats. Ecosystems will disappear. Even small temperature increases will cause coral bleaching and threaten some amphibians. Temperature rises of 3° or 4°C and more will lead to major extinctions around the globe [2].

III. ADVANTAGES OF GREEN ENERGY

A. Solar Energy

- 1) It is a clean source of energy which does not produce harmful gases as a co-product so have no effect on environment and human health.
- 2) Many everyday items such as calculator and other low power consuming devices can be powered by solar energy effectively.
- 3) It is a better source of energy for future generation as it last long forever (infinite).

B. Hydro Energy

- 1) It is one of the clean source of energy because does not create any by-product during conversion.
- 2) Hydroelectric power is a domestic source of energy, allowing each state to produce their own energy without being reliant on international fuel sources.
- 3) It is reliable, affordable and vast source of energy.
- 4) In addition to a sustainable fuel source, hydropower efforts produce a no. of benefits, such as flood control, irrigation and water supply.
- 5) Hydro electric power plant reservoirs collect rain water, which can then be used for consumption or for irrigation.
- 6) Hydroelectric installations bring electricity, highways, industry and commerce to communities, thus developing the economy, expanding access to health and education, also improving the quality of life.

C. Wind Energy

- 1) It is a clean fuel source does not pollute air. Wind turbines do not produce atmospheric emissions that cause acid rain or green house gases.
- 2) It is renewable source of energy require less cost.
- 3) Land around wind turbines can be used for other users e.g. farming.
- 4) In combination with solar energy they can be used to provide reliable as well as steady supply of electricity.

D. Geothermal Energy

- 1) It is a cheaper and affordable source of energy used for bath, heating homes and offices, preparing food, etc.
- 2) By using geothermal sources of energy present generations of human will not endanger the capability of future generation to use their old resources to the same amount.
- 3) This is also cost effective, reliable, sustainable and environment friendly.
- 4) Due to its low emissions geothermal energy is considered to have excellent potential for mitigation of global warming.

E. Vibration Energy

- 1) Vibration energy harvesting replaces the batteries in medical implants which is beneficial for the environment as these batteries contain toxic heavy metals.
- 2) We can use vibration energy to reduce the noise in environment which is mainly happening in industries or due to air craft's etc by vibration damping and vibration isolation.

IV. APPLICATIONS OF GREEN ENERGY

- 1) Use in calculators, road signs, satellites, etc. as solar energy.
- 2) Passive space heating by solar energy

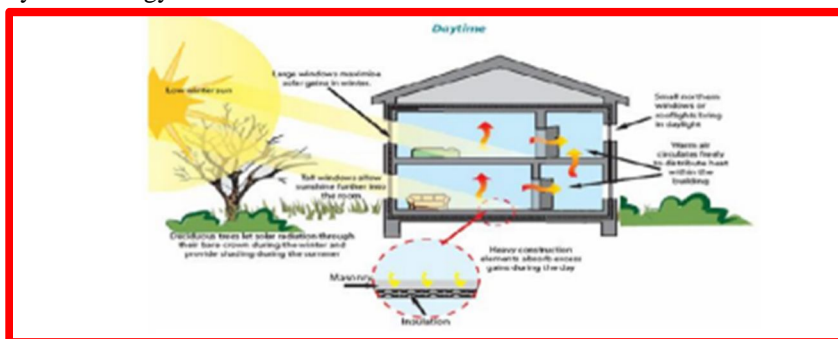

Fig.3: Passive space heating by solar energy

- 3) Warm up and keeping the food fresh by solar energy.

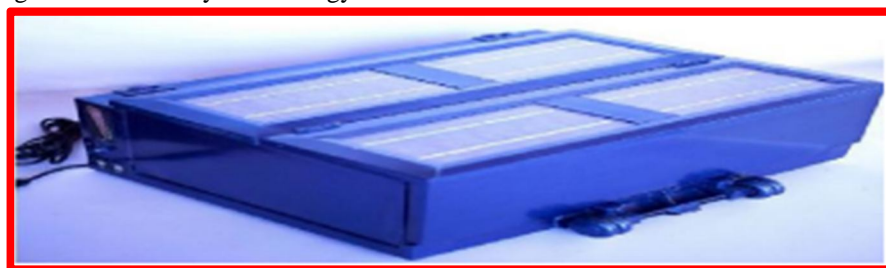

Fig.4: Solar Fridge

- 4) Water your plants with solar powered irrigation.
- 5) For hydrogen fuel production.

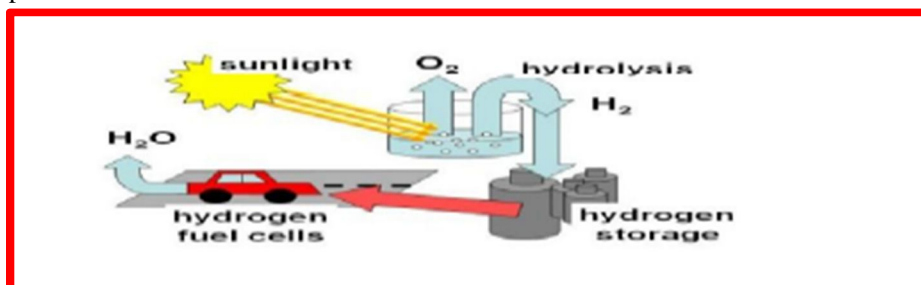

Fig.5: Hydrogen Fuel Production

9) Wind powered sorts like wind surfing, kite flying, kite surfing, hang gliding, Para sailing, wind skiing and more.



Fig.9: Wind Kites

10) Wind powered water pumps.

11) In farming like in fish farms in form of geothermal energy.



Fig.10: Geothermal Energy in Farming

12) Use in industries to dry fruits, vegetables, wood, wool to extract gold and silver from ore

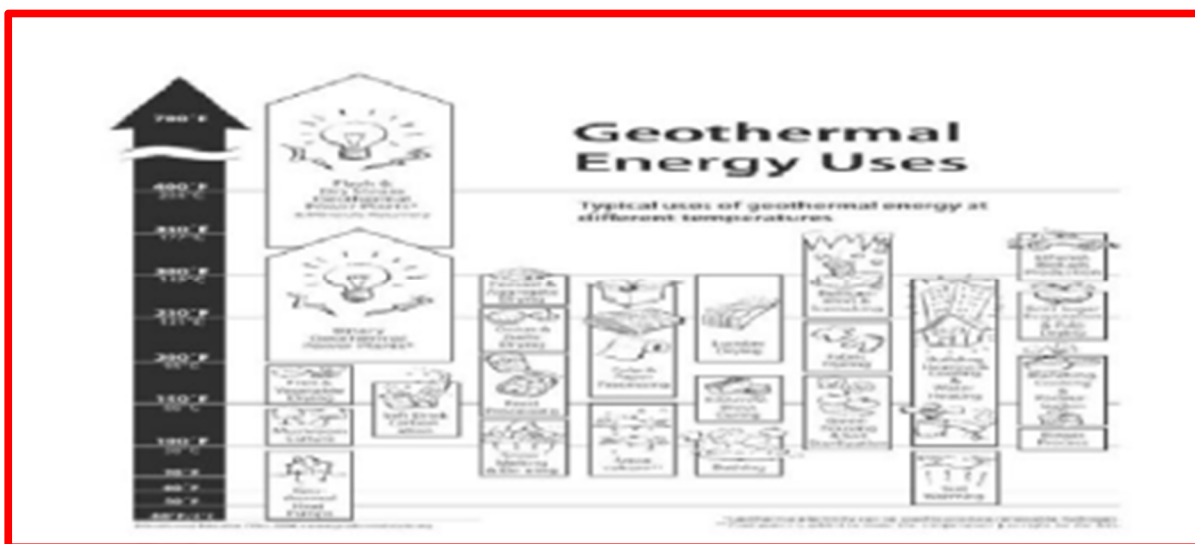

Fig.11: Uses of Geothermal Energy

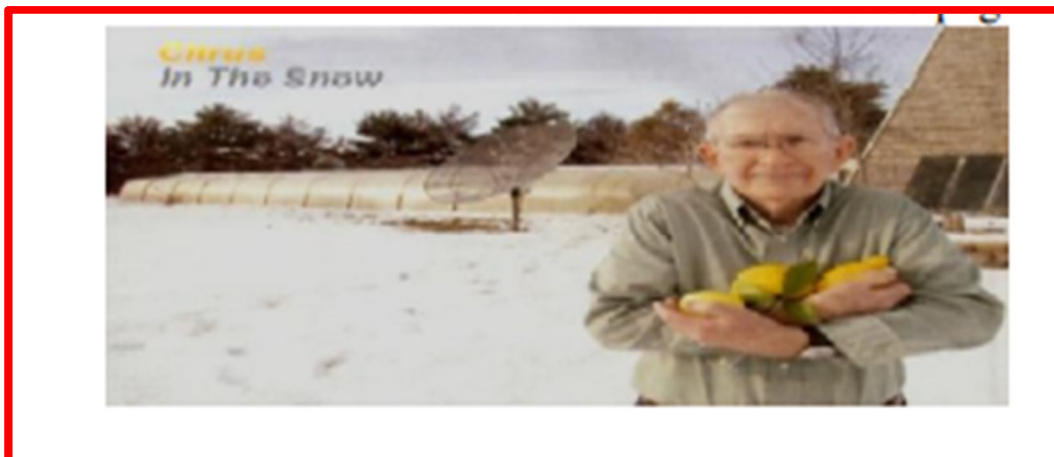

Fig.12: Geothermal Energy in Green Houses

13) Use to heat sidewalks and roads in order to prevent freezing in winters.



Fig.13: Geothermal Bike lanes

14) *Building Technologies:* Some wireless sensors are made for the structural monitoring and safety systems of the building when there is power cut.

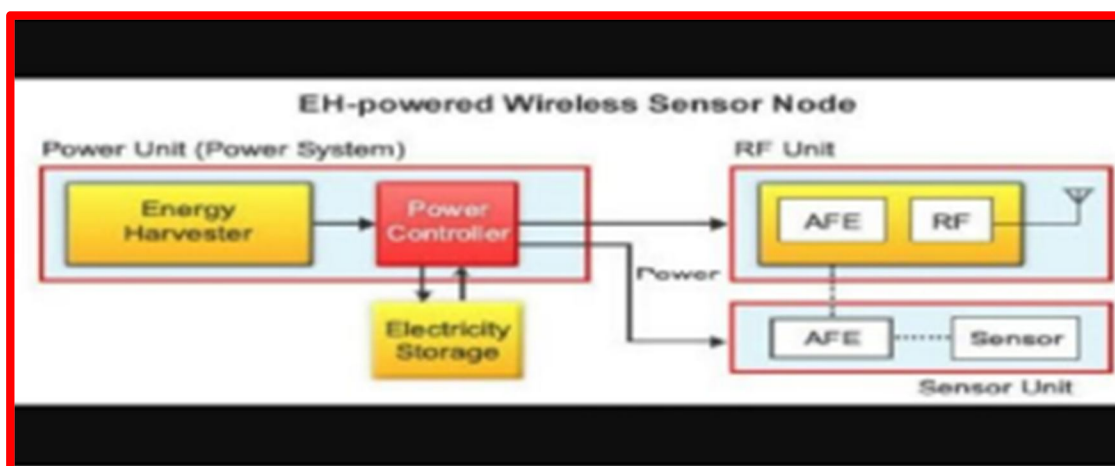

Fig.14: Wireless Sensors

15) *Medical Implants*: Some medical devices are deployed inside human bodies for their well being. But these devices need electricity to function properly which they get from the vibration of patient's own body movements such as heartbeats.

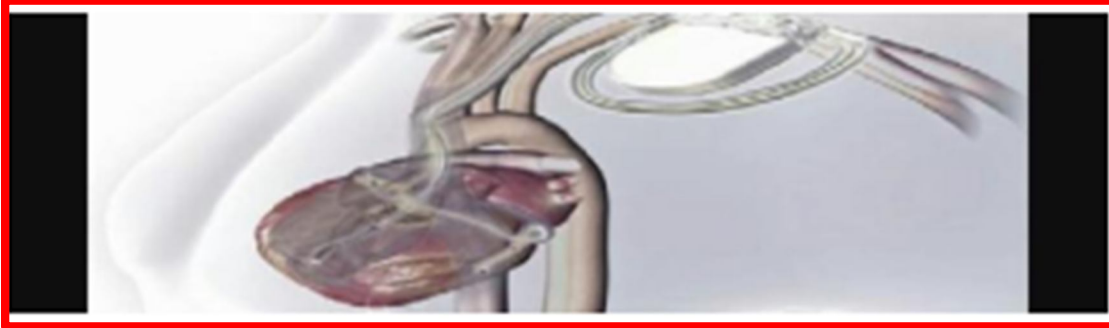

Fig.15: Medical implants

16) *Generating Electricity from the Weight of Cars & Pedestrians*: A new technology of generating sustainable energy from flow of vehicles is introduced by the researchers in Mexico. "This is a technology that provides sustainable energy and could be implemented at low prices, since it's a complement of already existing infrastructure: the concrete of streets and avenues," states Héctor Ricardo Macías Hernández, the developer of the system [8].



Fig.16: Generating Electricity from the Weight of Cars & Pedestrians

Mexican entrepreneurs developed a system capable of using the vehicular flow to generate electric energy [8]. An integrated ramp step which is made up of polymeric material is firstly installed which rises the street level about 5 cm. As the vehicles pass a pressure is exerted due to their weight on bellows which contains air which is expelled out through holes. Later this is compressed to produce electricity through a turbine. 17. *Innovative tanks*: Architect-designer invented some innovative tanks that can collect solar and water both at a time.



Fig.17: Innovative tanks

17) *Concept of translucent battery charging from sun:* A translucent lithium-ion battery that can be recharged in the sun is developed.

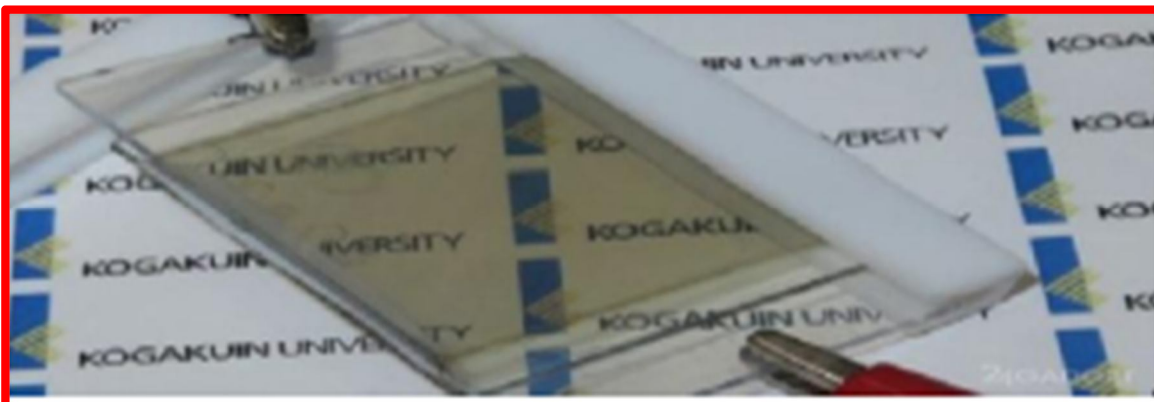

Fig.18: Translucent Battery



Fig.19: Sunny Paper for charging gadget

V. FUTURE SCOPE

Green Energy is having a future in almost every field of the world like industrial, agricultural, Medical, domestic, etc. Scientists already have found many forms of green energy such as solar, wind, hydro, etc. and now they are working on some new forms of energy like radiation and biomass so to reduce the usage of non renewable sources of energy as they are already depleting. In coming years efficiency of solar panels is going to increase and it can work even in cloudy weather as researchers are already working on it. A new combined form of solar and hydro is also coming called solar/wind hybrids. This technology combines the wind turbines with solar photovoltaic (PV) panels to produce higher level of energy and the studies have found that these are nearly double efficient than the present ones[9]. Like these there are technologies which are already invented or just the concepts are given and are still developing. These inventions let us to make an environment which is using green energy completely and is eco-friendly.

VI. CONCLUSION

Through this paper we are trying to focus on need for energy which is eco- friendly and can be renewed which requires technological development to obtain the best utilization of green energy. As the resources obtained naturally has the potential to protect world and reduce dependence on nonrenewable resources which are near to extinction. Seeking from the future aspect green energy is an alternative source for power generation, provide energy in unlimited ways. The only need is to aware people for energy conservation along with environment. This is a step to generate different forms of energy in most of the field with clean source (less use of fossil fuel). Day by day the demand of clean energy is increasing; green energy will fulfill the need with more advance technological systems. But it will take some time when every single house operate their electrical appliances by using their own power producing system such as solar panels, small wind turbines etc.



REFERENCES

- [1] https://en.wikipedia.org/wiki/Green_Energy_Act_2009
- [2] <http://tec.gov.in/pdf/StudyPaper/GET%20for%20Telecom%20Applications.pdf>
- [3] Source: <https://shaikmohasin.wordpress.com/tag/troughsystem/>
- [4] http://solarcellcentral.com/csp_page.html#tower_systems
- [5] Agreement No. : CE 36/2000, Study on the Potential Applications of Renewable Energy in Hong Kong, Stage 1 Study Report, December 2002
- [6] https://en.wikipedia.org/wiki/Wind_power
- [7] Vijay Laxmi Kalyani, Anjali Pious, Preksha Vyas, "Harvesting Electrical Energy via Vibration", Journal of Management Engineering and Information Technology, Volume -2, Issue- 4, Aug. 2015, ISSN: 2394 – 8124
- [8] <http://cleantechnica.com/2013/12/16/generating-electricityweight-cars-pedestrians-system-developed-exploit-energy-passingcars/>
- [9] <http://www.justenergy.com/blog/the-future-of-renewableenergy/>



10.22214/IJRASET



45.98



IMPACT FACTOR:
7.129



IMPACT FACTOR:
7.429



INTERNATIONAL JOURNAL FOR RESEARCH

IN APPLIED SCIENCE & ENGINEERING TECHNOLOGY

Call : 08813907089  (24*7 Support on Whatsapp)