



IJRASET

International Journal For Research in
Applied Science and Engineering Technology



INTERNATIONAL JOURNAL FOR RESEARCH

IN APPLIED SCIENCE & ENGINEERING TECHNOLOGY

Volume: 10 **Issue:** I **Month of publication:** January 2022

DOI: <https://doi.org/10.22214/ijraset.2022.39889>

www.ijraset.com

Call:  08813907089

E-mail ID: ijraset@gmail.com

Optimal Operation of Automotive Electrical System with Photovoltaic Generation and Three-level Battery Management Scheme

Dr. T. Murali Mohan¹, G. Bhanu Prakash²

¹Professor, Department of Electrical & Electronics Engineering, UCEK, JNTU Kakinada, India

²M.Tech, Department of Electrical & Electronics Engineering, UCEK, JNTU Kakinada, India

Abstract: For many years, the electrical power requirements in Automotive Electrical System (AES) have been quickly increasing and are predicted to continue to climb. This trend is being pushed by the introduction of a slew of new vehicle features. The constant growth in power needs is stretching the limitations of current automotive power generation and control technologies, stimulating the development of higher-power and higher-voltage electrical systems and components. Electrical power on a vehicle is not free. It comes as a direct result of consuming fuel within the engine to drive the alternator. With a typical engine efficiency of 44% and with present fuel costs this leads to onboard electrical power costs 4 times more than a typical household utility rate. Global oil and gas resource depletion, as well as environmental concerns, have prompted the automobile industry to build more efficient and eco-friendly cars in order to minimize fuel use and safeguard the environment. In our proposed Automotive Electrical system configuration, we have an AES system which is powered by an automotive alternator and battery combination where the alternator is driven by an IC engine and we have a hybrid energy system using a Rooftop PV array with a battery management system (BMS). We discovered that during the off state, the whole load of the automobile is dependent on the 12V lead acid battery for power, which causes the SOC to drop dramatically. As a result, the suggested model will include a flexible thin-film solar PV module positioned on the rooftop, which will be supported by a Maximum Power Point (MPPT) Tracking charge controller and will deliver energy to recharge the extra battery and meet the electrical requirements when the vehicle is stationary. When the vehicle is in motion, the existing alternator in the car's electrical system takes over the battery charging requirements, by this way, we can meet the electrical requirements of AES without running the engine for a long time by consuming fuel. The proposed model specialty is investigated using MATLAB/Simulink and compared with existing methods.

Keywords: Automotive Electrical System (AES), Internal Combustion Engine (ICE), Hybrid Energy System, Rooftop PV array, Maximum Power Point Tracking (MPPT).

I. INTRODUCTION

On a vehicle, there is no free electricity. It occurs as a result of the alternator being driven by the engine's fuel consumption connected by the belt. From many years, automotive electrical power consumption has been quickly increasing because of including electrical loads like a starter motor, including of various sensors, mobile chargers, various indication lamps, FM radios etc, and this trend is projected to continue. Due to the technical development of automobiles, their electricity consumption has grown significantly over the past years and electronic control units (ECUs) have become the key components in automotive [1]. Their objectives include the control of the power train, as well as safety and comfort requirements. In the case of HEVs, additional demand of 100 Watts electrical power increases the fuel consumption by 0.1 to 0.2 liters per 100 kilometers. Similarly, in the case of BEVs, the electrical driving distance is reduced by electronics. In order to maximize the operational range of HEVs and BEVs, alternative energy harvesting methods such as photovoltaics are considered [2]. The Basic AES schematic circuit shown in Fig 1. As we know that during off state the of vehicle entire loads depend on 12V lead acid batteries for their supply which SOC may reduce drastically. Lead-acid batteries have a low charging rate i.e fully saturated battery takes 14 to 16 hours and it also has a limited life cycle more repeated cycles may reduce battery life Another problem is the low conversion efficiency of the alternator due to belt and also low-efficiency engine due to this electricity produced in the car is four times the average household utility rate. As a result, the fuel expenses connected with generating electricity can be substantial and should no longer be overlooked.

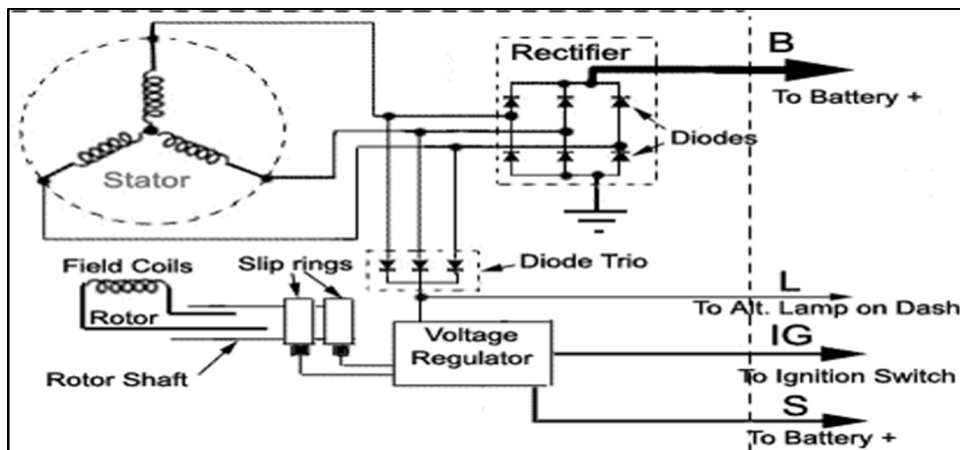

Fig. 1. AES basic circuit

In this project, we have addressed the topic of how improving the automotive electrical system can combat this problem by measurably reducing fuel costs. First, a fundamental overview of the automotive electrical system is given. Each of the major power-related elements of the automotive electrical system are reviewed. The project involves in addressing the problems above by adding extra battery bank by a conjunction of PV array with MPPT [3] and hence decreasing the load on the alternator and supplying sleep mode currents and loads with power generated for solar and ultimately reducing fuel consumption. A battery management scheme for battery protection is developed.

II. MATHEMATICAL MODELLING OF AES COMPONENTS

Automotive Electrical System (AES) is a combination of various devices belonging to different domains. So, we need to analyze each component individually to get an overall understanding about its parameters and their prominence. For ease of modelling, the whole AES is divided into atomic units like the Alternator model, Starter motor, Lead-acid battery, PV array, MPPT, and DC-DC converters.

A. Automotive Alternator

The two components that generate power are the rotor and the stator. The rotor spins past three stationary stator windings, or wire coils, around a fixed iron core that makes up the stator as the engine rotates the alternator pulley. A three-phase current is what it's called. The coil windings are equally placed around the iron shaft at 120-degree intervals. The rotor's alternating magnetic field causes an alternating current to flow in the stator. The AC current is delivered into a connected set of diodes via stator leads. To manage the current, two diodes are connected to each stator lead. The diodes are used to stop and direct the flow of current. Because batteries require DC electricity, the diodes act as a one-way valve, allowing current to flow only in one direction.

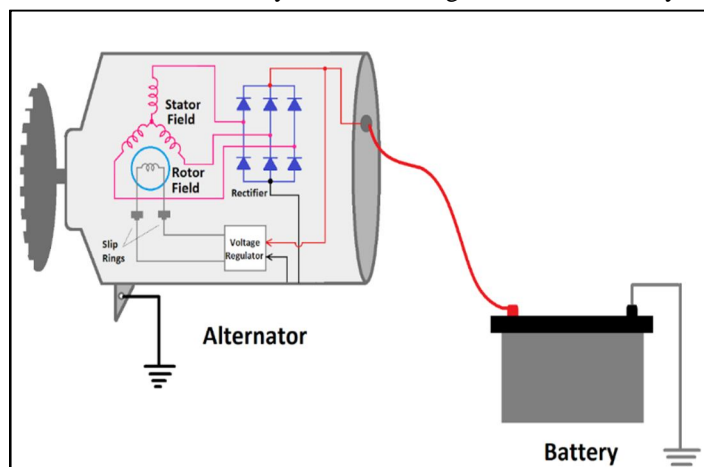

Fig. 2. Automotive alternator

Table 1: Automotive alternator Parameters

Parameter	Value
Rated power	2000VA
Rated voltage	20V
Frequency	50Hz
Field voltage	4.5V
Rated current	100A

B. Modelling of starter Motor

A starter, also known as a starter motor it is generally a DC motor, it is an electrical device that rotates (cranks) internal combustion engines to allow them to start under their own power. Initially starter motor gets supply from 12V Lead Acid battery it draws huge amount of current. Later the engine was detached from the starter motor as soon as it started running and now relies on the combustion process. The starter motor gear meets the teeth of the flywheel in this component, which is located on the engine's gearbox housing. Based on engine power starter motor power rating varies, in this we have used 5KW motor.

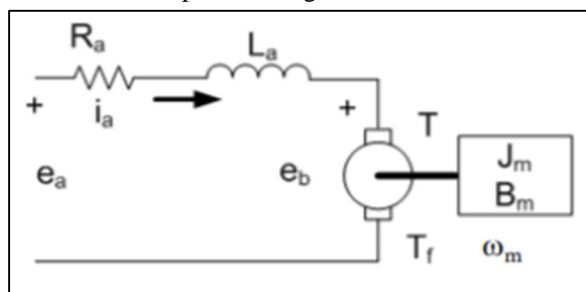

Fig. 3. Starter motor model

i_a = armature current e_b = back emf e_a = armature terminal voltage ω_m = motor speed (rad/sec) T = motor torque T_f = static friction torque R_a = armature resistance L_a = armature inductance J_m = rotational inertia B_m = viscous friction

Table 2: Starter Motor Parameters

Parameter	Value
Rated power	5KW
Rated Voltage	12V
Rated Torque	7.25N-m
Maximum Torque	10N-m
No-load speed	12000RPM
Rated Speed	6500RPM

C. Modelling of Lead-Acid Battery

In order to implement a better control strategy and justify the performance of the proposed topology in Automotive Electrical System, one must know the equivalent parameter model of lead acid battery as shown in Fig (4).

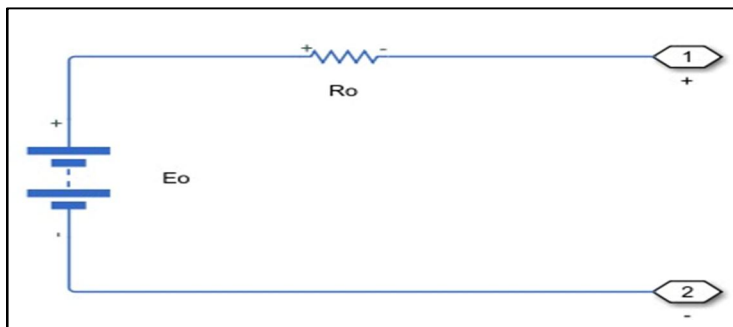

Fig. 4. Lead-acid battery equivalent model

The battery is modelled as a series resistor and a constant voltage source if the Battery charge capacity parameter is set to infinite. The block mimics the battery as a series resistor and a charge-dependent voltage source if the Battery charge capacity parameter is set as Finite. In this we have considered battery with no dynamics, no self-discharge, and with no aging. In the finite case, the voltage is a function of charge and has the following relationship:

$$V = V_0 \left(\frac{SOC}{1 - \beta(1 - SOC)} \right)$$

where:

- 1 SOC (state-of-charge) is the ratio of current charge to-rated battery capacity.
- 2 V_0 is the voltage when the battery is fully charged at no load, as defined by the Nominal voltage, Vnom parameter.
- 3 β is a constant that is calculated so that the battery voltage is V_1 when the charge is AH_1 . Specify the voltage V_1 and ampere-hour rating AH_1 using block parameters. AH_1 is the charge when the no-load (open-circuit) voltage is V_1 , and V_1 is less than the nominal voltage

Table 3: Battery Specifications

Parameters	Value
Rated Voltage (V)	12V
Rated Capacity	50Ah
Internal Resistance (Ro)	0.0025Ω

D. Mathematical Modelling of Photovoltaic Array

The mathematical equations of voltage and current are used and modelled using MATLAB/Simulink for PV array modelling. Solar cell modelling equations are simply multiplied by factors of series and parallel no of cells because an array is a series-parallel combination of solar cells. The single-diode electrical equivalent circuit of a PV cell is shown in Figure 5 is sufficient for PV Array modelling. It includes a current source (I_{ph}) in parallel with a diode (D), a shunt resistance (R_{sh}) and a resistance (R_s) in series.

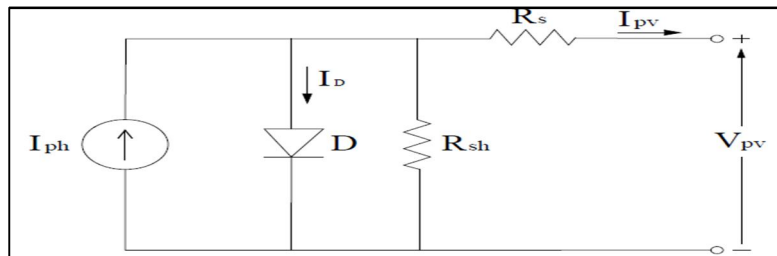

Fig. 5. PV array equivalent circuit

The current output of PV Array is:

$$I_{pv} = N_p * I_{ph} - N_p * I_s \left[\exp \left(\frac{V_{pv}/N_s + I_{pv}R_s/N_p}{V_t a} \right) - 1 \right]$$

Where;

I_{pv} = current generated by a single solar cell (A), V_{pv} = voltage generated by a solar cell (V), I_{ph} = current generated due to light or photocurrent (A), I_s = diode reverse saturation current (A) R_{sh} = shunt equivalent resistance (Ω)

R_s = series equivalent resistance (Ω), a = diode ideality factor, $V_t = kT/q$ = the thermal voltage of PV array (V)

q (= $1.602 * 10^{-19}$ C) = charge of electron (C), k (= $1.3806 * 10^{-23}$ J/K) = Boltzmann's constant (J/K), N_s = number of cells in series

N_p = number of cells in parallel

The photocurrent mainly depends on the solar irradiance and cell temperature. That means when the intensity of light and/or the corresponding temperature of the module changes, the current generated by the module also changes according to the following equation.

$$I_{ph} = [I_{pvn} + KI(T - T_n)] \frac{G}{G_n}$$

Where;

I_{pvn} = nominal light generated current (A), K_I = short circuit current or temperature coefficient (A/K)

T = actual and nominal temperature (K), $T_n = 25\text{ }^\circ\text{C}$ or 298 K = nominal temperature (K), G = irradiation level on module surface (W/m^2), $G_n = 1000\text{ W}/\text{m}^2$ = nominal irradiation

$$I_s = I_{sn} \left(\frac{T_n}{T} \right)^3 \exp \left[\frac{qE_g}{ak} \left(\frac{1}{T_n} - \frac{1}{T} \right) \right]$$

Where;

E_g = bandgap energy of semiconductor ($E_g = 1.12\text{ eV}$ for Si) and

I_{sn} = nominal saturation current.

Table (4): PV array Parameters

Parameters of Soltech 215 W Module	Value
Short circuit current (I_{sc})	7.84A
Open circuit voltage (V_{oc})	36.3V
Maximum power @ $1000\text{w}/\text{m}^2$ (P_{max})	215W
No of cells (N_{cell})	60
Voltage at maximum power point (V_{mpp})	29V
Current at maximum power point (I_{mpp})	7.35A
Series Resistance (R_s)	0.39383Ω
Shunt Resistance (R_{sh})	313.399Ω
Diode Ideality Factor (a)	0.98117
Temperature coefficient of I_{ph}	$0.102\%/^\circ\text{C}$

E. Buck Converter

Buck converter is a power electronic circuit that steps down the input DC voltage to the output load. Thus, the average output voltage of the buck converter is smaller than the source voltage. Buck converter circuit is shown in fig6. The working principle of the circuit depends on the condition of the switch. The switch has two states, which are closed (ON) or open (OFF). Switch (S) is generally a power electronic component such as MOSFETs. The operating mode buck converter consists of two types of continuous and discontinuous. Circuit operating modes depend on the current through the inductor. In continuous mode, the inductor current never reaches zero while in discontinuous mode will reach a value of zero for a time.

The Output voltage under continuous conduction mode is:

$$V_o = V_s \left(\frac{t_{ON}}{T} \right)$$

$$V_o = V_s D \quad \Rightarrow \quad 0 < D < 1 ; \text{ Where } D \text{ is duty cycle.}$$

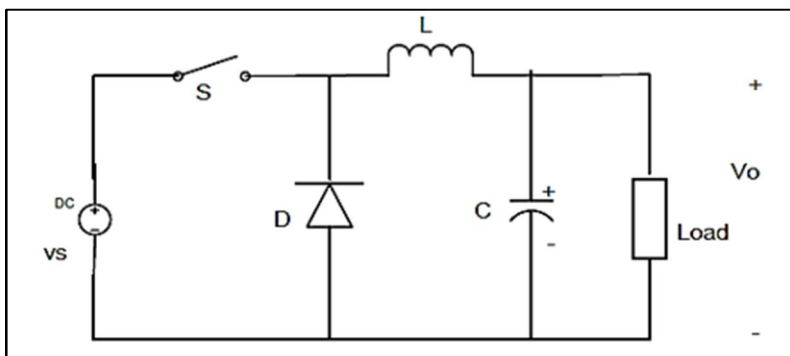

Fig 6: Buck converter model

Table 5: Buck Converter Parameters

Buck Converter	Value
Switching Frequency	5KHz
Inductor(L)	0.783mH
Capacitor(C)	364μF
Vin	29V
Vout	12V

III. PROPOSED SIMULINK MODELS

Before discussing about the proposed AES topology, we will discuss about the basic model & its SIMULINK model shown in fig. 7 and its demerits compared with existing model.

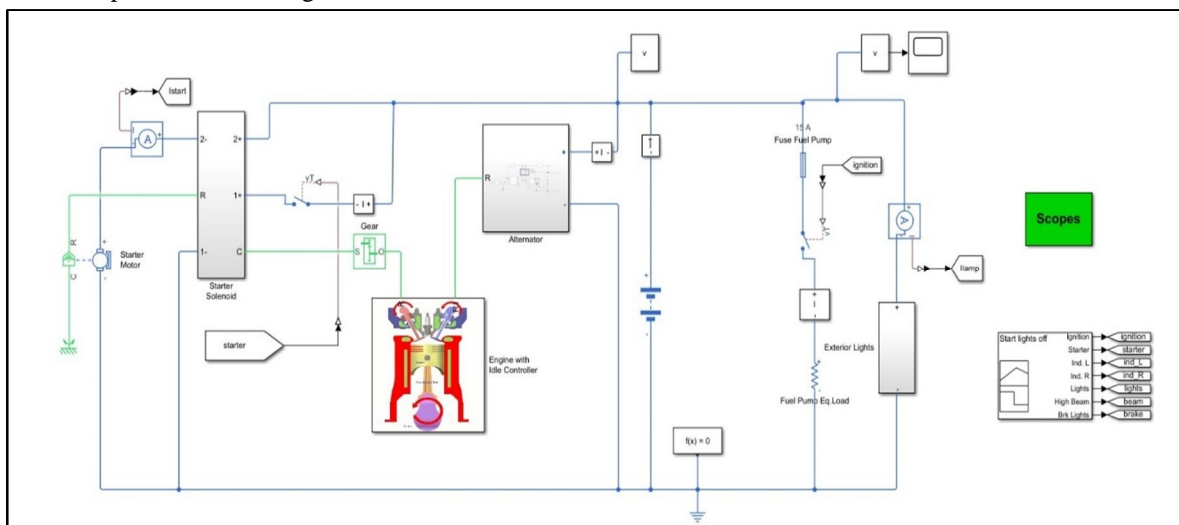

Fig. 7. AES Model without PV system SIMULINK MODEL

Engine averaged model is developed with the help of parameters like car tire diameter and we have given the speed manually. The engine subsystem is shown in below fig. 8 it is the model for starting, idle and also for some constant speed which is same for both cases with PV and without PV.

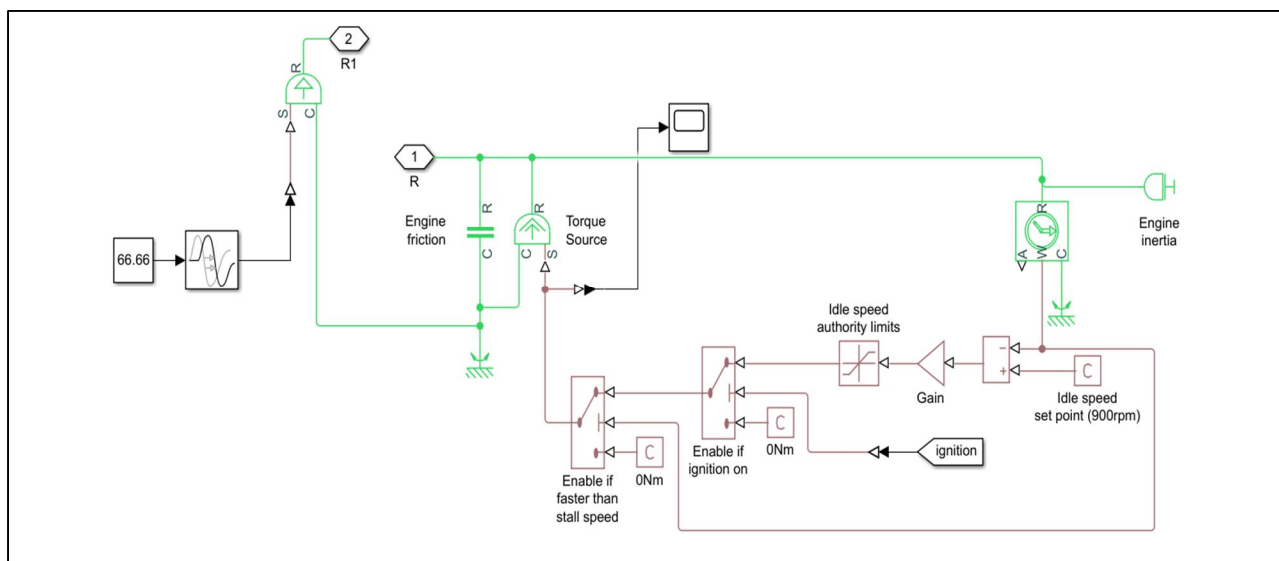

Fig. 8. Engine averaged SIMULINK MODEL

To start the engine in IC Engines it requires starting system which contains clutch, Starter solenoid, Pinion, starter motor etc. By pressing clutch the plunger will move the pinion gear flywheel teeth which is located on starter motor shaft will attached to the engine crank shaft later when we turn the ON the key solenoid coils get supply from the battery and will acts as a switch to the starter motor. So, when we turn the key a huge amount of current will flow from solenoid coils to starter motor which will rotate the pinion which is attached to engine later engine cranking occurred and car will start. After the car has started the plunger will comes back and supply to the starter motor will be turned OFF. The above fig. 9 represents clutch, plunger, solenoid subsystem

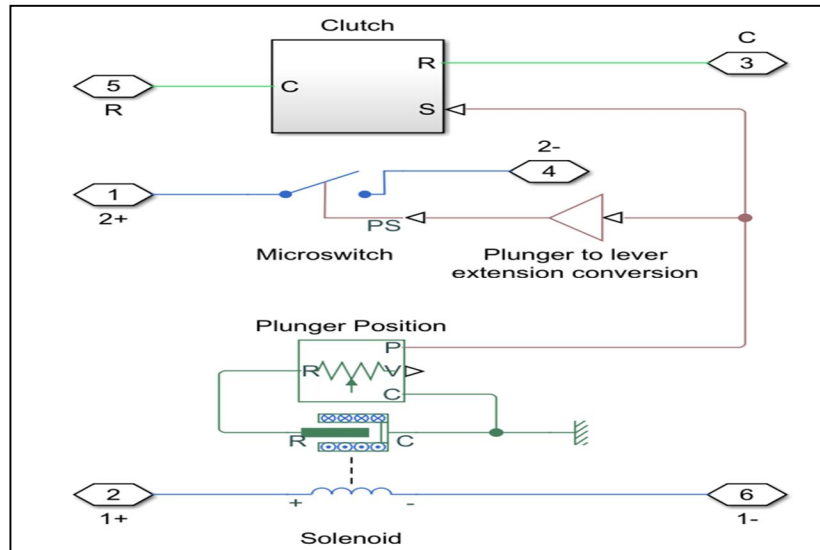

Fig. 9. Clutch, plunger & solenoid SIMULINK MODEL

During starting huge current demanded by starting system mainly starter motor to crank the engine. This huge amount for current is supplied by 12V lead acid battery, so the battery SOC is reduced. Not only for starting battery will also support the electrical requirements when the engine is off so the charge of battery will be keep falling. So, the battery cannot serve continuously for the electrical loads in car, So, there should be some way to recharge the battery and power to all the electrical loads such as various lighting systems, mobile chargers and all electrical and electronic accessories in car. So, charging system serves this purpose for charging the battery and give supply to the electrical components in car. The Charging system consist of Automotive Alternator which is attached to engine via belt and also it contains full bridge rectifier and to convert supply from alternator from AC to DC. This DC supply will charge the battery and also used for self excitation of its own field winding. This Automotive system is shown in fig. 10 is same for both topologies.

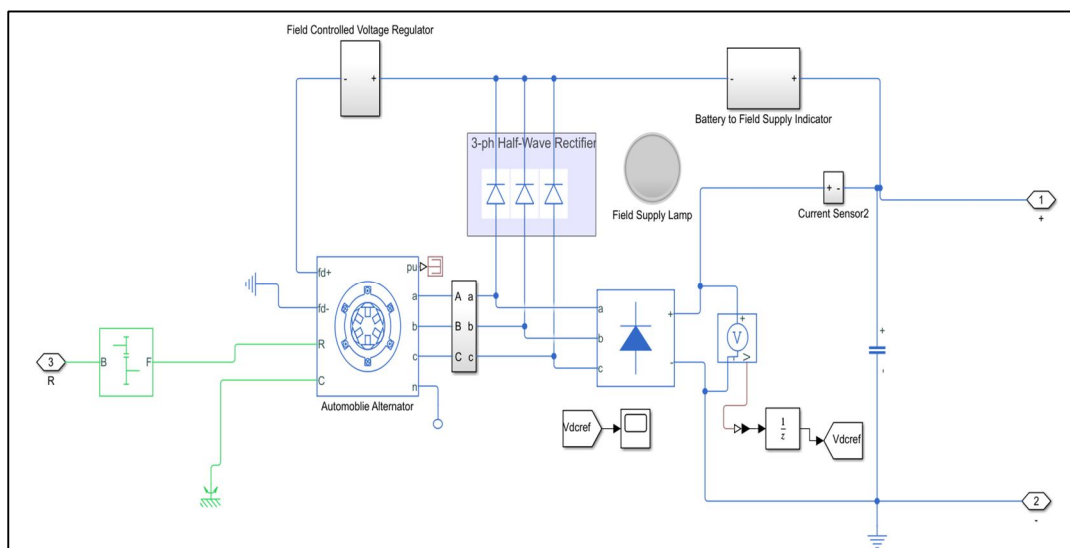

Fig. 10. Automotive charging system SIMULINK MODEL

Automotive Alternator will keep on running in conjunction with engine. So, the output of alternator will vary continuously with the speed so it is not desirable for this case a field voltage regulator is included in that circuit to set field voltage in limits there by output in limits. That field voltage regulator subsystem is shown in fig. 11.

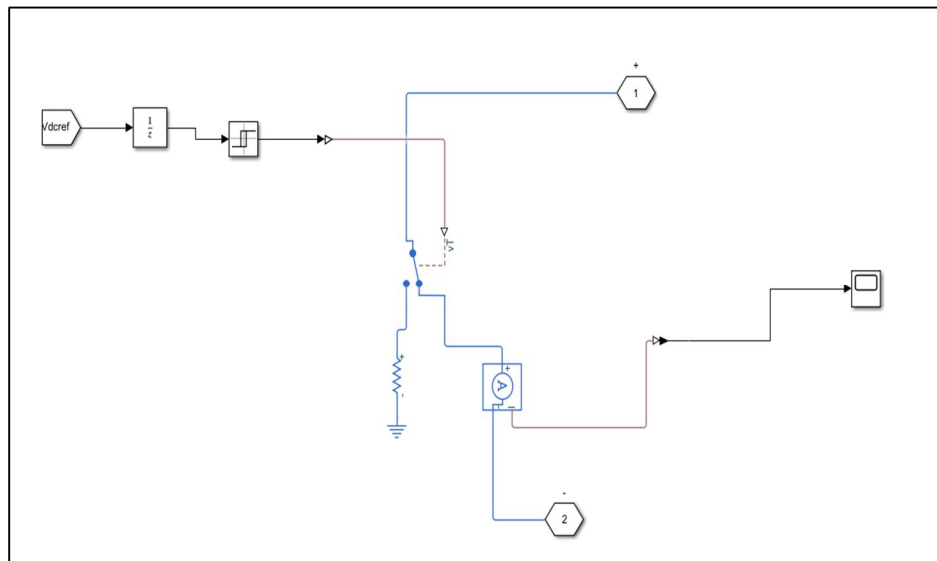

Fig. 11. Alternator field regulator averaged SIMULINK MODEL

The proposed model will have the flexible thin-film solar PV module positioned on the roof top, supported by a Maximum Power Point Tracking charge controller, provides the energy to recharge the car battery when the vehicle is stationary. Because the MPPT is based on the Power Versus Voltage characteristics of a Solar Panel, the voltage of the Solar Panel may be regulated to give maximum power to the load by inserting the MPPT DC-DC Converter between the Solar Panel and the Battery. The existing alternator in the car's electrical system takes over the battery charging requirements when the vehicle is in motion. In the SIMULINK model we have included the fuel consumption display system

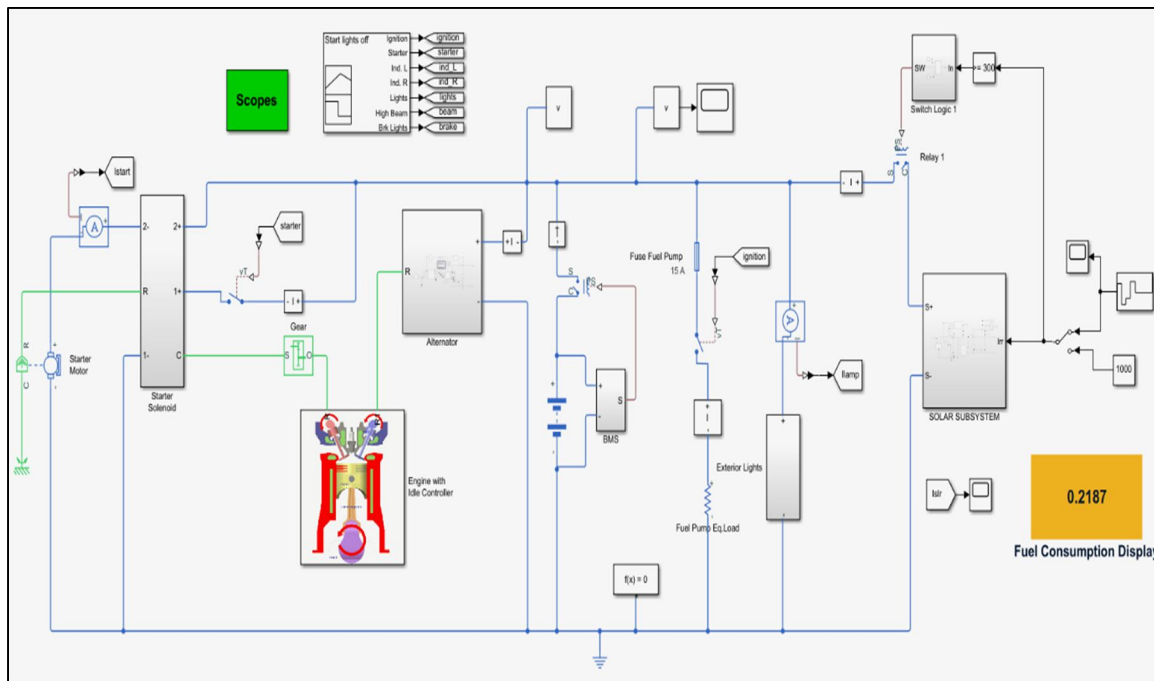

Fig. 12. Final SIMULINK MODEL with PV based Hybrid Energy Support

The fig. 12 consists of all the possible loads in automotive, it consists of starter motor, solenoid, ignition system, lighting systems, Fuel pump motor is modelled as equivalent resistance and also hybrid energy system using PV array with constant irradiance and with variable irradiance values, and fuel indication and BMS.

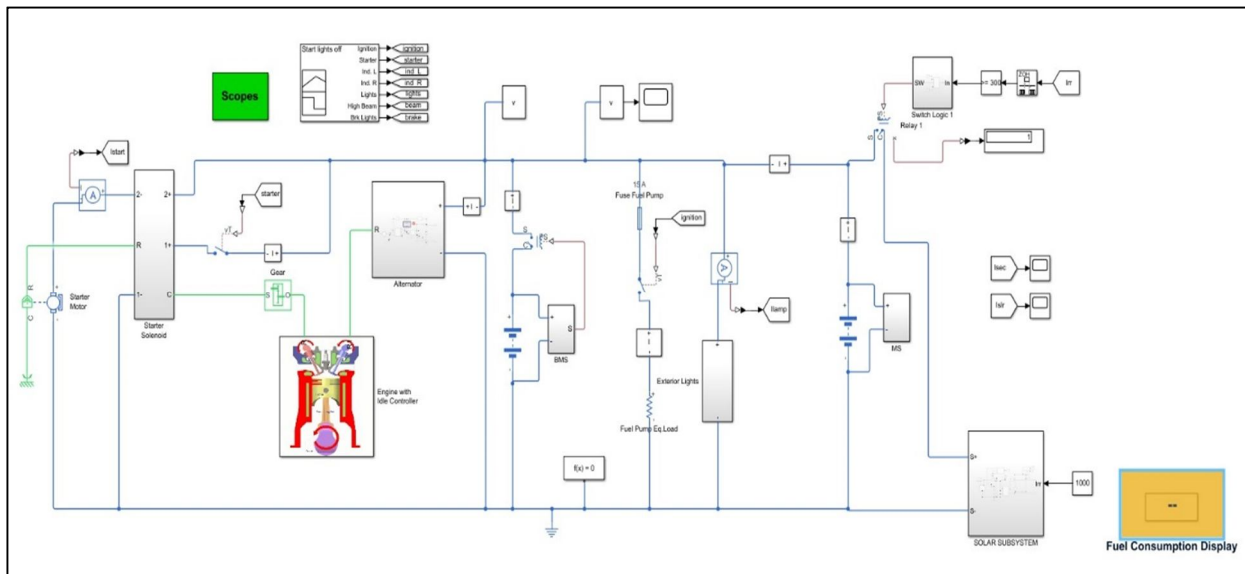

Fig 13 AES model with extra battery and PV array SIMULINK MODEL

The fig. 13 represents AES with hybrid energy system and extra battery backup which is charged by solar power which is used with in combination with main battery. The subsystem shown in fig. 14 represents solar panel with MPPT algorithm and Buck-converter. various parameters of the solar array is addressed in tabular (4) form.

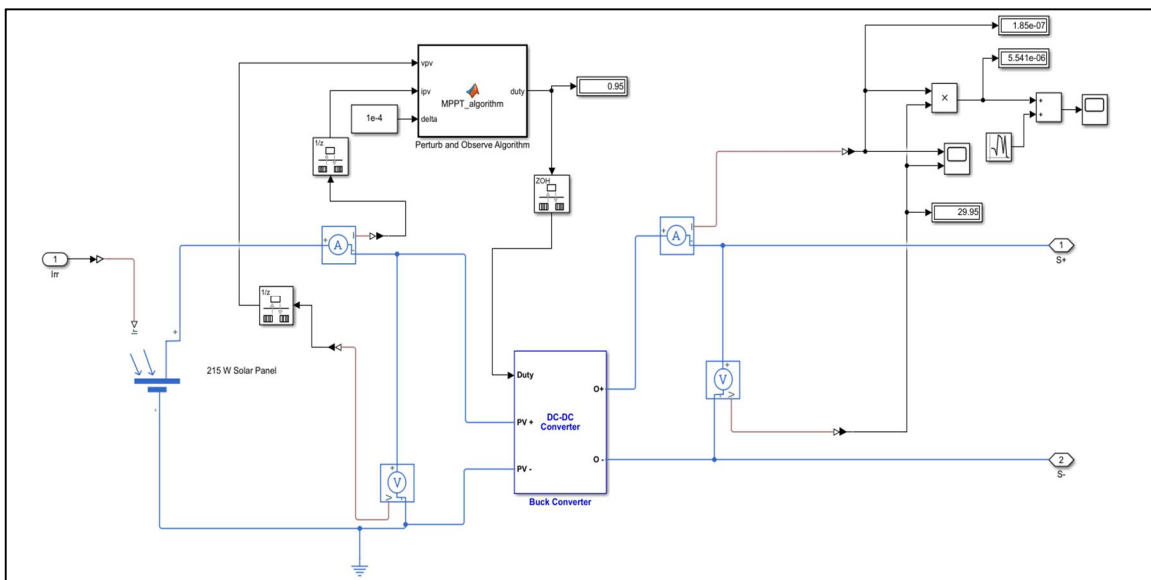

Fig 14 PV array MPPT algorithm and Buck-converter SIMULINK MODEL

A MPPT is used for extracting the maximum power from the solar PV module and transferring that power to the load. A Buck converter serves the purpose of transferring maximum power from the solar PV module to the load. A Buck converter acts as an interface between the load and the module. By changing the duty cycle the load impedance as seen by the source is varied and matched at the point of the peak power with the source so as to transfer the maximum power. Therefore, a MPPT technique is required to obtain maximum power from a PV system. MPPT is used in photovoltaic (PV) systems to maximize the photovoltaic array output power, irrespective of the temperature and radiation conditions and of the load electrical characteristics with the use of DCDC converter like buck converter configuration.

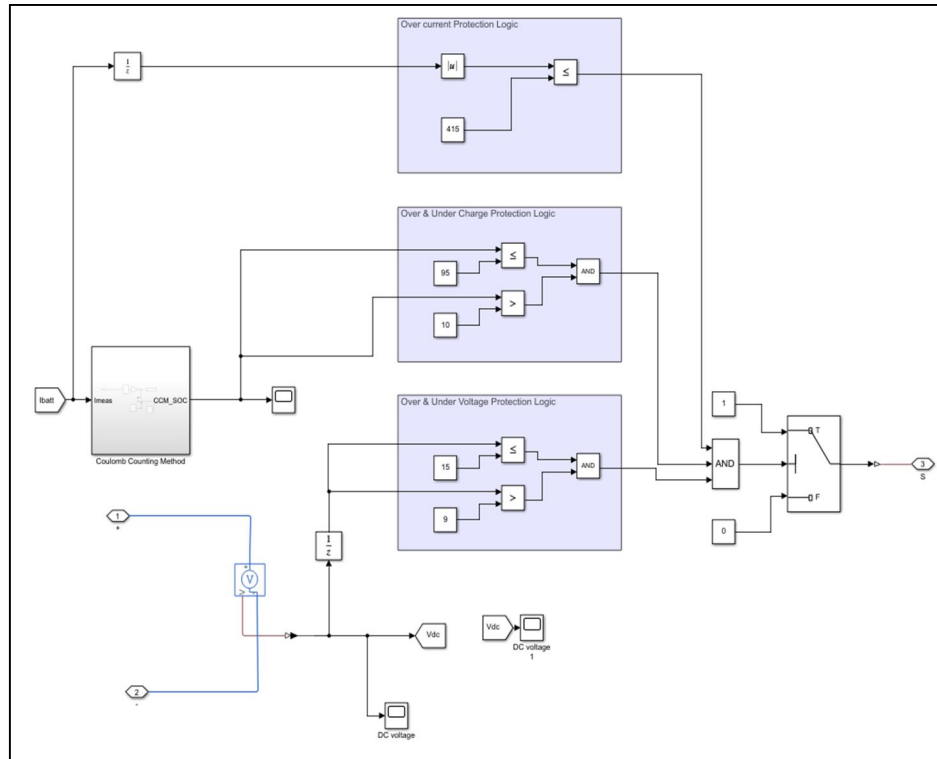

Fig. 15. Battery Management System (BMS) Simulink Model

The subsystem shown in fig. 15 represents BMS with various protections for battery like over and under voltage, over current protection and also it has over charge protection its state of charge (SOC) measurement is explained in subsystem shown in fig. 15. The battery voltage limits are 15V-9V, and battery charge percentage limits are 95%-10%, battery current limit is 415A. So, by providing all these protections we can protect the battery from damage due to over charge and over current and over voltage and its life time is improved.

IV. RESULTS & DISCUSSIONS

In this section, the simulation results of AES with and without PV array under simulation using MATLAB 2020a are presented.

A. Basic AES Operation

Below fig. 16 represents switching time of various electrical loads like ignition, starter motor and various lights turn ON time sequence.

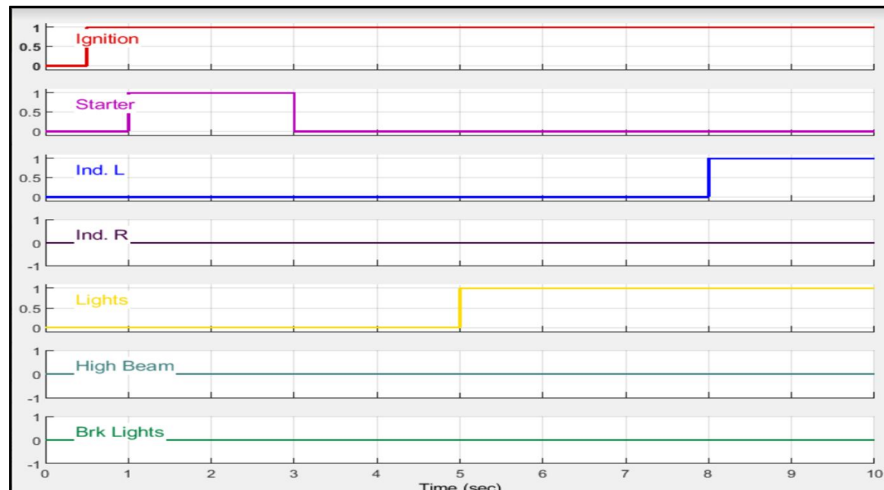

Fig. 16. load turn ON sequence

The fig. 17 shows current vs Time characteristics of various automotive loads. solenoid switch draws current during starting to connect starter motor its conduction time is observed in figure, later starter motor draws huge amount of current to crank the engine and after engine has started its supply will be disconnected after 3 seconds it is observed, petrol pump load also included.

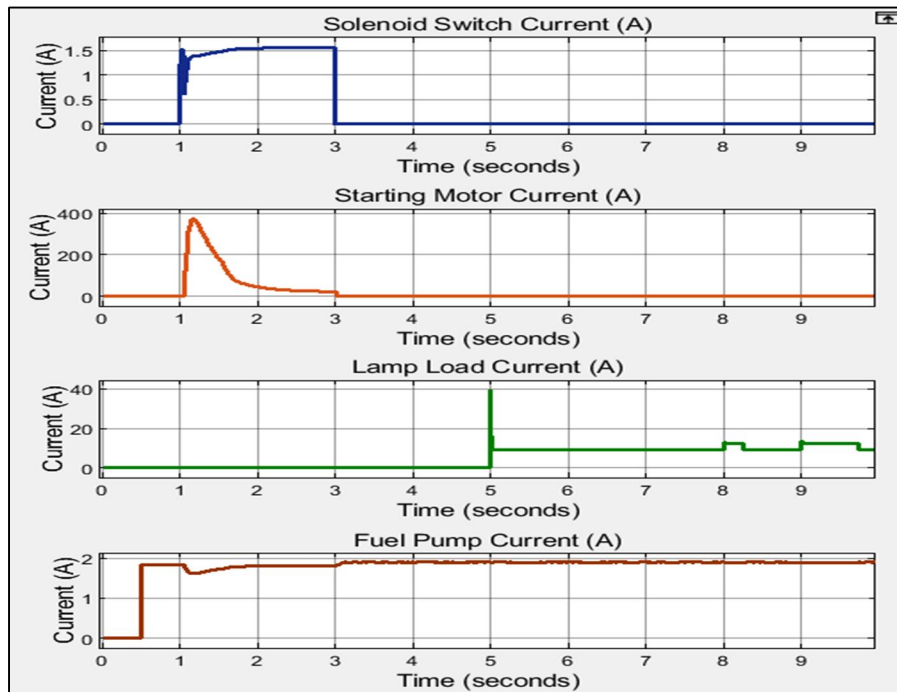

Fig. 17. AES Load currents versus time under basic AES operation

The above fig. 18 represents battery voltage and current characteristics and also alternator output voltage and output current waveforms. From the above figure we have observed that upto 3seconds solenoid and starter motor draws supply from lead acid battery to start the engine it is identified by observing battery waveforms.

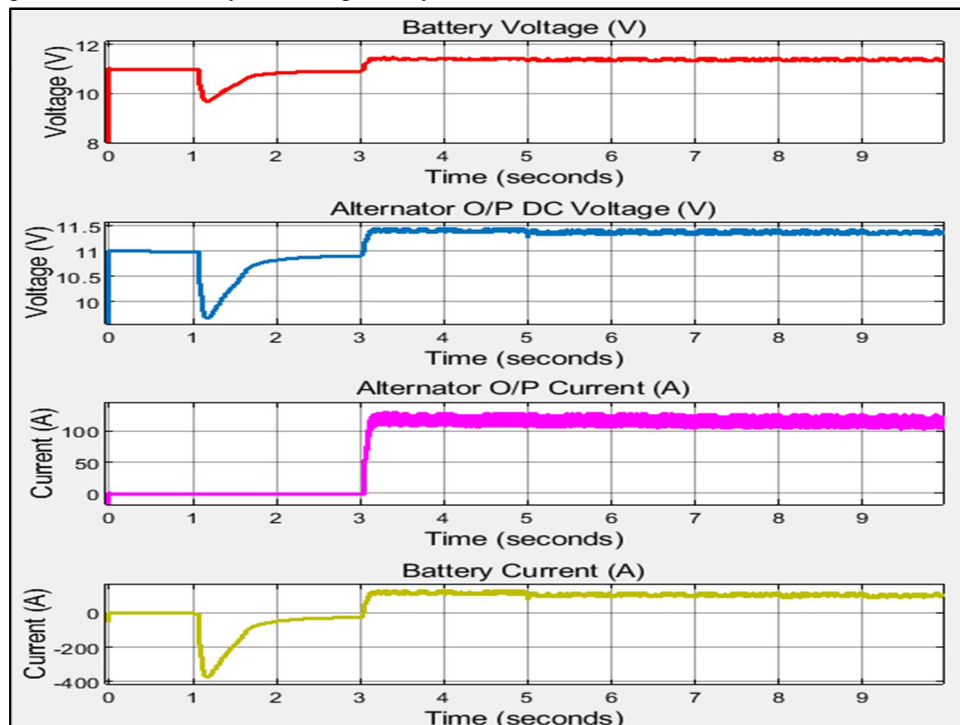

Fig. 18. Battery and alternator Voltages and Currents under Basic AES operation

As we have observed in fig. 19 that SOC of battery is reduced starting and later alternator charged the battery & hence the SOC% increased.

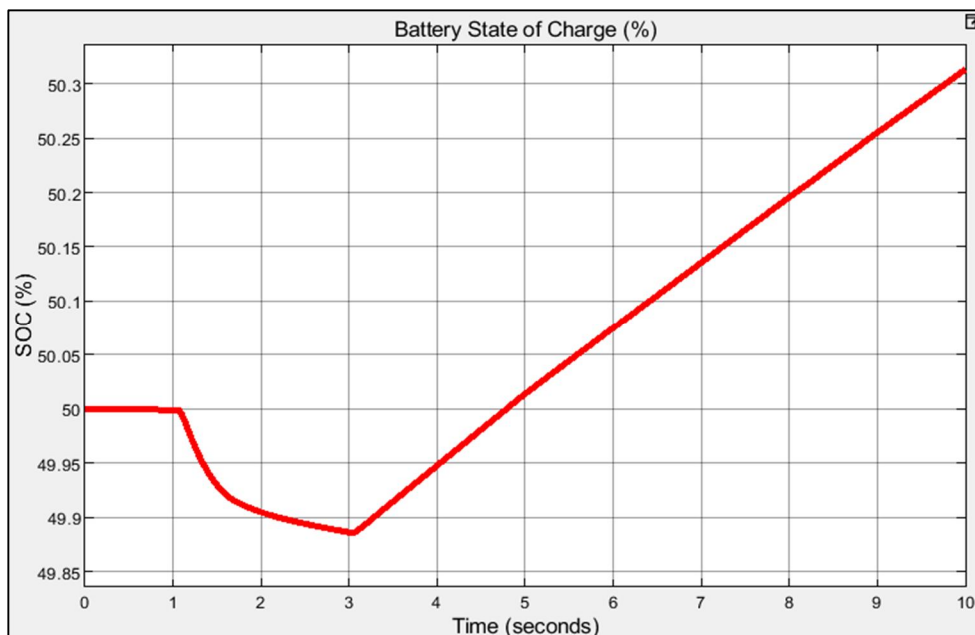

Fig. 19. Battery SOC (%) waveform without PV array

B. AES operation with PV Array

When Automotive Electrical System operated with the battery and 215 W PV array with constant irradiance of 1000W/m^2 the following are its output waveforms.

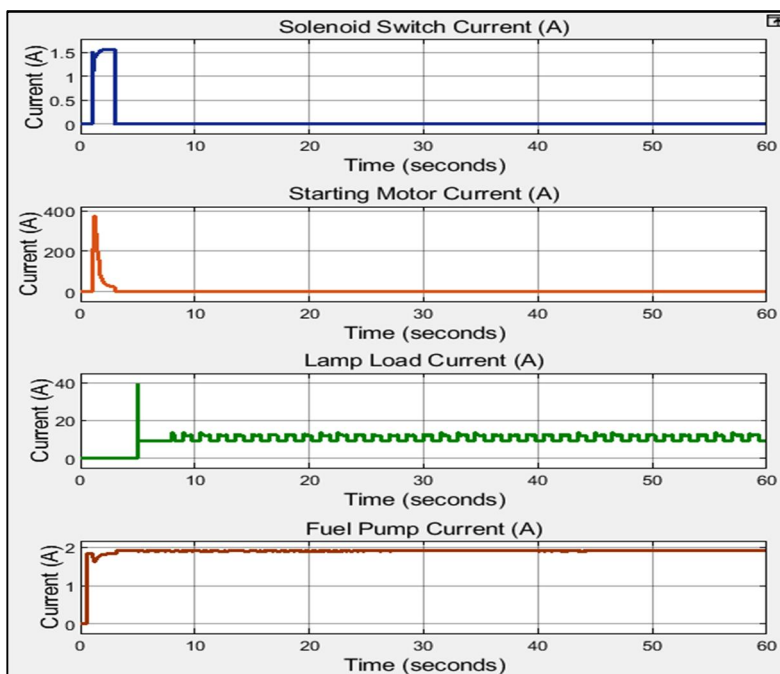

Fig. 20. Battery and alternator Voltages and Currents with PV

The waveforms shown in above fig. 20 represents current drawn by AES loads. It consists of solenoid switch and starter motor combinedly call as starting system and current drawn by various lamps loads and also current drawn by fuel pump. These loads are supplied from main battery current and also by current generated by solar Array.

Fig. 21 represents current and voltage wave forms of PV array we have observed that current and voltages has changed accordingly in way to get maximum power from the solar panel. Here we have used P&O algorithm to track MPPT. By this way we can give some support to the existing AES system.

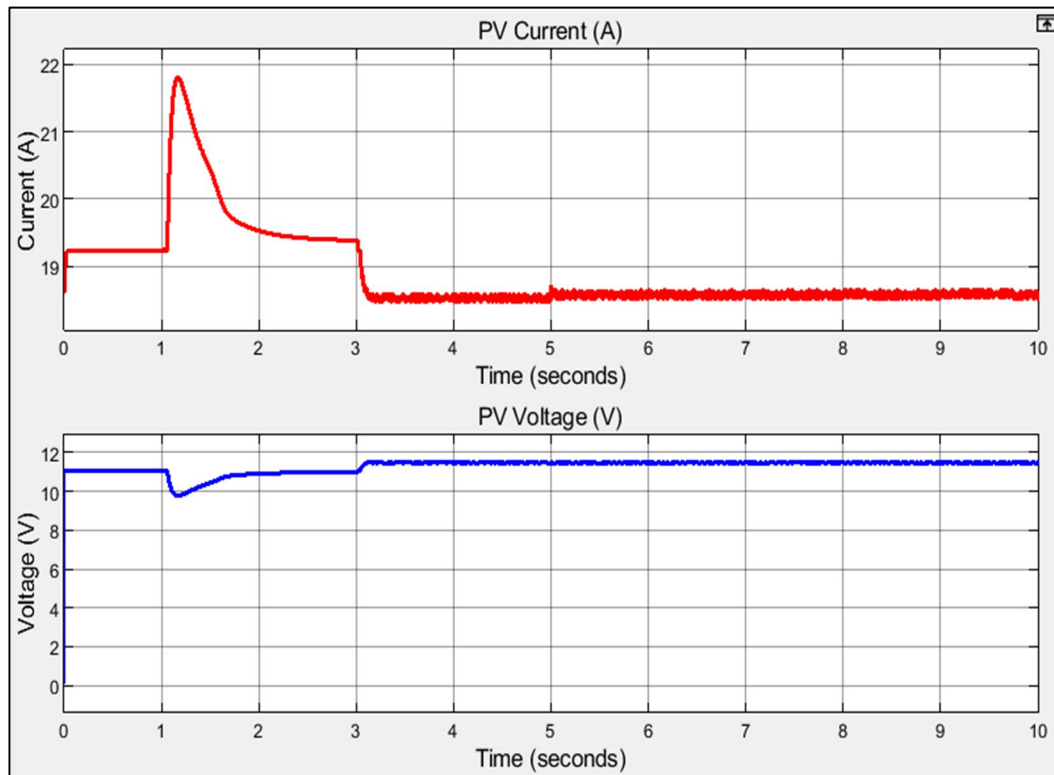

Fig. 21. PV array current(A) and voltages(v) with respect to time

The waveform shown in fig. 22 represents solar array output power. We have observed that solar array power has build constantly with constant irradiance and MPPT.

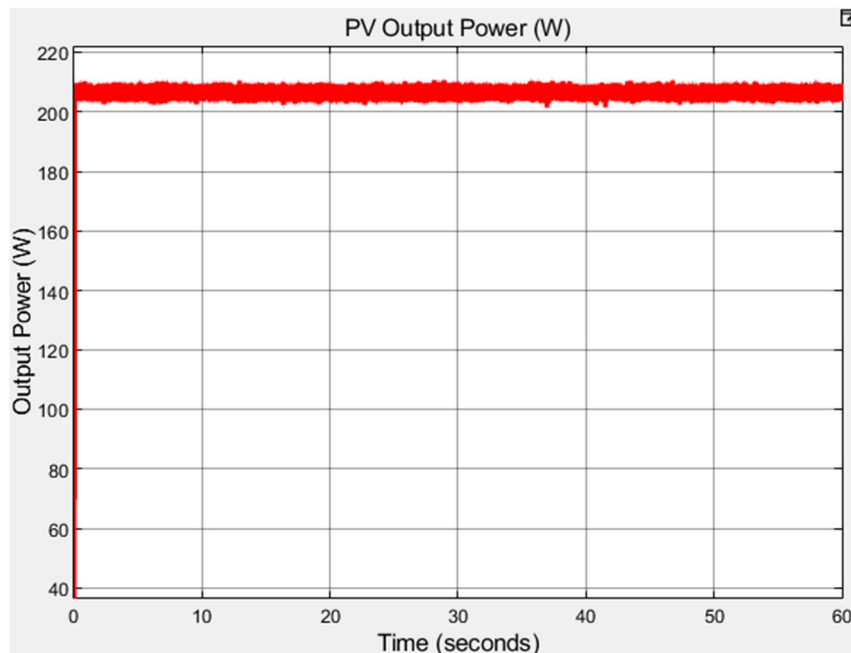

Fig. 22. PV array output power(W)

The amount of fuel consumed by the engine to run the alternator to meet the demand of AES loads is represented in the fig. 23. In that we have observed that fuel consumed by the engine is being increased with time of operation.

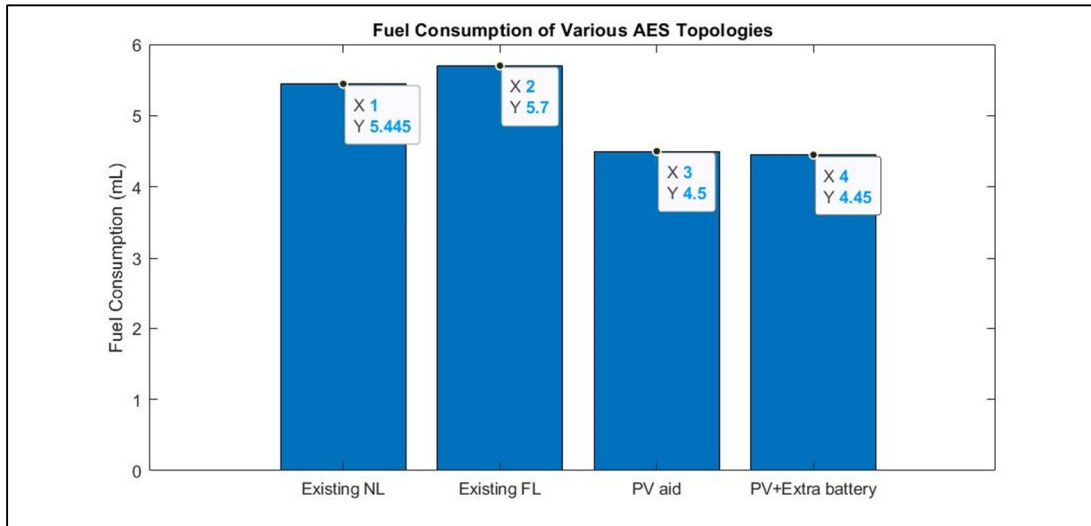

Fig. 23. Fuel consumption of various AES topologies

Fuel consumption of various AES topologies like No-load (only starting load), existing Full load, PV array aid to the existing system, PV array extra battery aiding the existing system. We have observed that fuel consumed in full load is 5.7mL per min that equal 342mL per hour which is roughly 35 RS/hr only consumed by the engine to supply to the electrical loads. We also observed that with the including of rooftop solar array the fuel consumption is reduced to 4.5mL per min with the same load on AES system that means 270mL per hour which is roughly 27 RS/hr only consumed by engine to supply the loads, which is less than existing system cost. This will show more effective for large vehicles and small vehicles for longer duration of operation.

V. CONCLUSION

Increase in electrical and electronic accessories in automotive system and increasing fuel prices and environmental concerns provide automotive industry to produce more efficient vehicles. However, because to the constraints imposed by the energy supply of existing Lead acid battery, there are still some questions about its performance and dependability. In this we have developed a battery-Rooftop PV array Hybrid Energy System to supply power to AES in a best efficient way. The goal is to reduce the fuel consumed by the engine to provide supply to the automotive loads by hybrid operation of rooftop PV array. In these various topologies are included for storing of PV power when we have constant irradiance of 1000W/m². Here we have observed that it has costed around 35 RS/hr for existing regular AES system to supply its loads which is around 350 RS/hr for 10hours of operation of vehicle which is higher than the conventional power generation for unit cost. So with the proposed hybrid energy system for AES system, we have got fuel consumption around 27 RS/hr and it is around 270 RS/hr for 10 hours of operation which is less than convention system as and also we know the solar power is free of cost. By integrating the solar panels less energy from ICE is demanded. With a smaller engine system, the overall efficiency of AES system gains a significant improvement. As a result, fuel consumption and pollutant emission can be reduced.

REFERENCES

- [1] E. Ceuca, R. Joldes and E. Olteanu, "Simulation of automotive alternator - solution for increasing electrical power," 2006 IEEE International Conference on Automation, Quality and Testing, Robotics, 2006, pp. 292-297, doi: 10.1109/AQTR.2006.254545.
- [2] Prem Sunder R, Sundaravadivelu K and Prabakaran P, "A novel approach to a Solar cell based battery charger for an automotive application," 2014 International Conference on Advances in Electrical Engineering (ICAEE), 2014, pp. 1-3, doi: 10.1109/ICAEE.2014.6838540. [3] M Khalid, S S Sheikh, A K Janjua, and H A Khalid, "Performance Validation of Electric Vehicle's Battery Management System under state of charge estimation for lithium-ion Battery," 2018.
- [3] Z. Li and A. Khaligh, "An integrated parallel synchronous rectifier and bi-directional DC/DC converter system for solar and wind powered hybrid electric vehicle," 2009 35th Annual Conference of IEEE Industrial Electronics, 2009, pp. 3779-3784, doi: 10.1109/IECON.2009.5415373. [5] Sai Krishna .V, J. Ramaprabhakar, and G. Prabhakar, "Electric Vehicle Designing, Modelling and Simulation," 2018.
- [4] M. M. Pisani, D. Iannazzone, M. Sorrentino and G. Rizzoni, "Analysis of Fuel Savings Enabled by Photovoltaic Panel Addition on a 48V Mild Hybrid Vehicle," 2019 23rd International Conference on Mechatronics Technology (ICMT), 2019, pp. 1-5, doi: 10.1109/ICMECT.2019.8932120. [7] G. Guruvareddiyar and Ramachandran Ramaraj, "Super Capacitor Based Energy Recovery System from Regenerative Braking used for Electric Vehicle Application," IEEE, 2019.



- [5] M. K. Darshana, K. Karnataki, G. Shankar and K. R. Sheela, "A practical implementation of energy harvesting, monitoring and analysis system for solar photo voltaic terrestrial vehicles in Indian scenarios: A case of pilot implementation in the Indian Railways," 2015 IEEE International WIE Conference on Electrical and Computer Engineering (WIECON-ECE), 2015, pp. 542-545, doi: 10.1109/WIECON-ECE.2015.7443989. [9] Gergana VACHEVA, Vladimir DIMITROV, and Nikolay HINOV, "Modelling and Control of Bidirectional Buck-Boost Converter for Electric Vehicles Applications," in IEEE, ELMA 16th Proceedings, 2019, vol. ELMA, no. 16th.
- [6] C. Schuss, T. Fabritius, B. Eichberger and T. Rahkonen, "Impacts on the Output Power of Photovoltaics on Top of Electric and Hybrid Electric Vehicles," in IEEE Transactions on Instrumentation and Measurement, vol. 69, no. 5, pp. 2449-2458, May 2020, doi: 10.1109/TIM.2019.2962850.
- [7] V. K. Viswambaran, A. Ghani and E. Zhou, "Modelling and simulation of maximum power point tracking algorithms & review of MPPT techniques for PV applications," 2016 5th International Conference on Electronic Devices, Systems and Applications (ICEDSA), 2016, pp. 1-4, doi: 10.1109/ICEDSA.2016.7818506.
- [8] P. T. szemes and M. Melhem, "Analyzing and modeling PV with "P&O" MPPT Algorithm by MATLAB/SIMULINK," 2020 3rd International Symposium on Small-scale Intelligent Manufacturing Systems (SIMS), 2020, pp. 1-6, doi: 10.1109/SIMS49386.2020.9121579.
- [9] K. Ng, Y. Huang, C. Moo and Y. Hsieh, "An enhanced coulomb counting method for estimating state-of-charge and state-of-health of lead-acid batteries," INTELEC 2009 - 31st International Telecommunications Energy Conference, 2009, pp. 1-5, doi: 10.1109/INTLEC.2009.5351796.



10.22214/IJRASET



45.98



IMPACT FACTOR:
7.129



IMPACT FACTOR:
7.429



INTERNATIONAL JOURNAL FOR RESEARCH

IN APPLIED SCIENCE & ENGINEERING TECHNOLOGY

Call : 08813907089  (24*7 Support on Whatsapp)