



IJRASET

International Journal For Research in
Applied Science and Engineering Technology



INTERNATIONAL JOURNAL FOR RESEARCH

IN APPLIED SCIENCE & ENGINEERING TECHNOLOGY

Volume: 9 Issue: XII Month of publication: December 2021

DOI: <https://doi.org/10.22214/ijraset.2021.39301>

www.ijraset.com

Call:  08813907089

E-mail ID: ijraset@gmail.com

Review: Observation on CFD Analysis of ZnO and TiO₂ Nanofluid with Oil and Ethylene Glycol in Square and Helical Coil Heat Exchanger

Rakesh Kumar¹, Vijaykant Pandey²

¹M-Tech Research Scholar, Bhabha Engineering Research Institute, Bhopal (M.P.), India

²Assistant Professor, Bhabha Engineering Research Institute, Bhopal (M.P.), India

Abstract: Helically coiled heat exchangers are globally used in various industrial applications for their high heat transfer performance and compact size. Nanofluids can provide the excellent thermal performance in helical coil heat exchangers. Research studies on heat transfer enhancement have gained serious momentum during recent years and have been proposed many techniques by different research groups [1]. A fluid with higher thermal conductivity has been developed to increase the efficiency of heat exchangers. The dispersion of 1-100nm sized solid nanoparticles in the traditional heat transfer fluids, termed as nanofluids, exhibit substantial higher convective heat transfer than that of traditional heat transfer fluids. Nanofluid is a heat transfer fluid which is the combination of nanoparticles and base fluid that can improve the performance of heat exchanger systems. In this present paper the efforts are made to understand that how to compare the heat transfer rate in Copper helically coiled tube and squared coiled tube heat exchanger using Zinc Oxide and Titanium Dioxide Nano fluid by studying research papers of various authors.

Keywords: Helical Coil, Nano-fluid, Heat Exchanger, CFD, Pressure Drop, Temperature Distribution.

I. INTRODUCTION

In most of the Industries, the designing and thermal evaluation of heat exchangers is generally carried out in order to reduce cost, material and energy and to obtain maximum heat transfer. The main challenge in heat exchanger design is to make it compact and to get maximum heat transfer in minimum space. The passive enhancement technique using coiled tube has significant ability in enhancing heat transfer by developing secondary flow in the coil. Due to enhanced heat transfer the study of flow and heat transfer in helical coil tube is of vital importance.

Through the growth of thermal engineering and industrial intensification, the need of efficient and compact heat transfer systems has been increased. In wide-ranging, the heat transfer enhancement methods are classified into two groups. Active method is the method which requires external power, whereas passive method does not require any direct external power. Helically coiled tube heat exchangers (HCTHE) as well as nano-fluids are regarded as passive heat transfer enhancement methods.

The HCTHEs are widely used in many applications, such as electricity generation and nuclear industries, HVAC, piping systems, chemical reactors and refrigeration systems due to its high thermal efficiency and compactness (low volume to surface ratio). The curvature of helical coil which persuades secondary flow, in combining with more heat transfer area, contributes to the heat transfer enhancements of HCTHEs. Numerous studies have indicated that helically coiled tubes are superior to straight tubes when working in heat transfer applications.

The centrifugal force induced due to the curvature of the tube results in the secondary flow development which enhances the heat transfer rate. This phenomenon can be valuable, especially in the laminar flow regime. Heat transfer fluid is one of the serious factors as it disturbs the size and cost of heat exchanger systems. Conventional fluids like oil and water have partial heat transfer potentialities.

For reduce cost and meet the increasing demand of industry and commerce we have to develop different types of fluids it is our top priority.

By chance, the growths in nanotechnology make it possible to get higher efficiency and cost saving in heat transfer methods. Nanoparticles are occupied as the fresh group of materials which having potential applications in the heat transfer area.

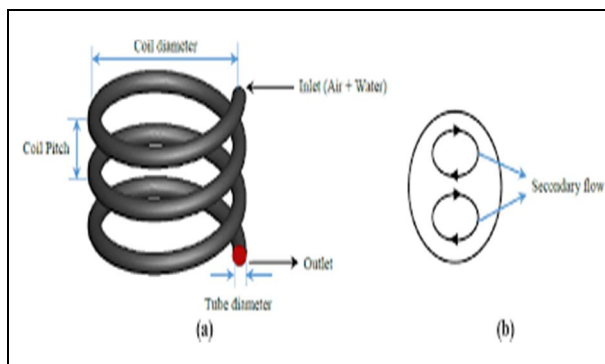

Figure 1 [11]

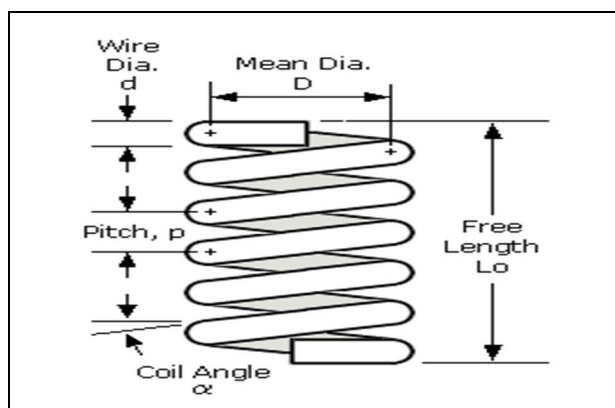

Figure 2 [12]

A. Nano Fluid

Nano fluid is nothing but it is a fluid particles which have less than even a micron (9-10 times) smaller in diameter and highly reactive and proficient material which can be used to increase feature like rate of reaction, thermal conductivity of any metal or material and they are that much reactive and strong.

The following benefits are expected when the nano fluid circulates the nano particles: [2]

- 1) **Heat Conduction is Higher:** The thermal interface is directly available if the particles are better than 20 nm & if they carry 20% of their atoms on their surface. The nanoparticle is of μ size so there will be the advantage in the movement of particles and it increased the heat transfer because of micro convection of fluid. When the nano particles having large heat surface area then the large heat transfer is allowable. Dispersion of heat is increasing in the fluid at a faster rate because of large heat transfer. When there will be a rise in temperature then the thermal conductivity of Nano fluid increases significantly.
- 2) **Stability:** Nano fluids have nanoparticle of which is smaller in size (9-10 times smaller) or in μ size, so they are light in weight, that's why the chances of sedimentation are reduced. When sedimentation is dropping it will provide the stability in Nano fluid by settling the nano-particles.
- 3) **Choking Not Occurs in Micro Passage Cooling:** For transferring of heat in heat exchanger the Nano fluid is a best option in overall and they can be perfect for micro passage uses where high heat loads are faced. A big area of heat transfer and directing fluids will occur by the mixture of micro path and Nano fluid and it cannot be managed with meso or micro-particles because they clog micro passages. Nano particles are smaller in size it is in μ which is very small to micro passage.
- 4) **Probabilities of Erosion Reduced:** The momentum which is conveyed by a solid wall is minor because nanoparticles are very small. The probability of erosion of components is reducing when the momentum reduces and it occurs in pipelines, pumps and heat exchangers.
- 5) **Pumping Power is Reducing:** Pumping power is increasing by a feature of ten. When the heat transfer of conventional fluid is increased by a feature of two. If there is a simple increase in fluid viscosity then the pumping power will be increased satisfactory. Thus, a large savings in pumping power can be attained. Thermal conductivity can also be increased by small volume fraction of particles.

II. LITERATURE REVIEW

Helical coil is very compact in structure and it possess high heat transfer coefficient that why helical coils heat exchangers are widely used. In literature it has been informed that heat transfer rate of helical coil is larger than straight tube.

K. Abdul Hamid et. al. [1] has done work on pressure drop for Ethylene Glycol (EG) based Nano fluid. The Nano fluid is prepared by dilution technique of TiO_2 in based fluid of mixture water and EG in volume ratio of 60:40, at three volume concentrations of 0.5 %, 1.0 % and 1.5 %. The experiment was conducted under a flow loop with a horizontal tube test section at various values of flow rate for the range of Reynolds number less than 30,000. The experimental result of TiO_2 Nano fluid pressure drop is compared with the Blasius equation for based fluid. It was observed that pressure drop increase with increasing of Nano fluid volume concentration and decrease with increasing of Nano fluid temperature insignificantly. He found that TiO_2 is not significantly increased compare to EG fluid. The working temperature of Nano fluid will reduce the pressure drop due to the decreasing in Nano fluid viscosity.

Hemasunder Banka et. al. [2] have done an analytical investigation on the shell and tube heat exchanger using forced convective heat transfer to determine flow characteristics of nano fluids by varying volume fractions and mixed with water, the nano fluids are titanium carbide (TiC), titanium nitride (TiN) and ZnO Nano fluid and different volume concentrations (0.02, 0.04, 0.07 & 0.15%) flowing under turbulent flow conditions. CFD analysis is done on heat exchanger by applying the properties of nano fluid with different volume fractions to obtain temperature distribution, heat transfer coefficient and heat transfer rate. He found that heat transfer coefficient and heat transfer rates are increasing by increasing the volume fractions.

M. Balchandaran et. al [3] have done experimental study and CFD simulation of helical coil heat exchanger using Solid works Flow Simulation using water as fluid. The fluid used for both coil and tube side is water. The flow rate of both fluids is maintained below as laminar and the flow rate of cold fluid is kept constant while that of hot fluid is changed. The readings during experimental study are taken once steady state has reached. The performance parameters pertaining to heat exchanger such as effectiveness, overall heat transfer coefficient, velocity contours, temperature contours etc. have been reported. Based on the results, it is inferred that the heat transfer rates and other thermal properties of the helical coil heat exchanger are comparatively higher than that of a straight tube heat exchanger.

Arvind Kumar Pathak et. al. [4] has done his study on the comparison of CFD analysis of Natural Fluid and Nano fluid in a helical coil heat exchanger. He has used water as a natural fluid and Titanium Oxide (TiO_2) and Zinc Oxide (ZnO) is used as a Nano fluid with base as water. He has fabricated a helical coil of aluminium and copper by bending 1000 mm of tube with 8 mm tube diameter, pitch 15 mm and coil diameter is 35 mm. He found that aluminium coil gives more pressure drop on Zinc oxide Nano fluid as compared to other tubes and fluids.

B. Sidda Reddy et al. [5] studied helical tube heat exchanger as compared to straight tubular heat exchanger in both counter flow and parallel flow by variable parameters like pitch, mass flow rate, temperature and pitch coil diameter. He use outside diameter of stainless steel cylinder of 63.5 mm and inside diameter of stainless steel cylinder 1.058D mm, thickness of tube vary from 6 mm to 9 mm, flow rate of cold and hot water is taken 0.0625 kg/s and 0.166 kg/s. The initial temperature of cold and hot water is 300C and 1000C is taken. Result show that heat transfer increase in counter flow configuration when hot fluid mass flow rate is increased. Increase in pitch coil diameter decreases the rate of heat transfer at same configuration and at same mass flow rate. Also if the coil pitch increases there is decrease in heat transfer at same mass flow rate. Helical coils ensuring larger surface area which allows the fluid to be interacting with the walls for greater period of time. So that there is enhancement in heat transfer as compare to that of straight pipe.

Karishma Jawalkar et. al. [6] has done CFD analysis of Manganese oxide, Silicon Dioxide and Zinc oxide nano-fluid on copper helical coil by using oil as a base fluid, She fabricated a copper coil helical coil of 1000 mm length, 50mm PCD, pitch of 15 mm, and the diameter of tube is 8 mm made in Solid works, she observed after doing CFD analysis that the nano-fluid which has high thermal conductivity and specific heat that fluid will give high pressure drop. As compare to water the oil is used as base fluid oil and creates more pressure. The pressure drop is more when Zinc oxide nano-fluid flow is used.

K Palanisamy [7] investigates the heat transfer and the pressure drop of cone helically coiled tube heat exchanger using (Multi wall carbon nano tube) MWCNT/water nanofluids. The MWCNT/water nanofluids at 0.1%, 0.3%, and 0.5% particle volume concentrations were prepared with the addition of surfactant by using the two-step method. The tests were conducted under the turbulent flow in the Dean number range of $2200 < De < 4200$. The experiments were conducted with experimental Nusselt number is 28%, 52% and 68% higher than water for the nanofluids volume concentration of 0.1%, 0.3% and 0.5% respectively. It is found that the pressure drop of 0.1%, 0.3% and 0.5% nanofluids are found to be 16%, 30% and 42% respectively higher than water.

Shiva Kumar et. al [8] have worked on both straight tube and helical tube heat exchanger. He has compared CFD results with the results obtained by the simulation of straight tubular heat exchanger of the same length under identical operating conditions.

Results indicated that helical heat exchangers showed 11% increase in the heat transfer rate over the straight tube. Simulation results also showed 10% increase in nusselt number for the helical coils whereas pressure drop in case of helical coils is higher when compared to the straight tube.

T. Srinivas et. al. [9] have done experimental study on heat transfer Enhancement using Copper Oxide (CuO)/Water Nano fluid in a Shell and Helical coil heat exchanger. Experiments have been carried out in a shell and helical coil heat exchanger at various concentrations of CuO nanoparticles in water (0.3, 0.6, 1, 1.5 & 2%), speed (500, 1000 and 1500rpm) and shell side fluid (heating medium) temperatures (40, 45 & 50°C). Water has been used as coil side fluid. He found that the heat transfer rate increases with increase in concentration of CuO/water Nano fluid. This can be attributed to increased thermal conductivity of base fluid due to the addition of nano particles.

Vinita Sisodiya et. al. [10] study on the use of Helical coil heat exchangers (HCHEs) with (Aluminium Oxide) Al_2O_3 -Water phase change material to understand if HCHEs can yield greater rates of heat transfer. An analytical study was conducted using a counter flow HCHE consisting of 8 helical coils. Two analysis was conducted, one where water was used as heat transfer fluid (HTF) on the coil and sell sides, respectively; while the second one made use of different Volume fractions of Al_2O_3 and water on the coil and shell sides, respectively. The NTU effectiveness relationship of the HCHE when Al_2O_3 fluid is used approaches that of a heat exchanger with a heat capacity ratio of zero. The heat transfer results have shown that when using an Al_2O_3 , an increase in heat transfer rate can be obtained when compared to heat transfer results obtained using straight heat transfer sections. It has been concluded that the increased specific heat of the Al_2O_3 as well as the fluid dynamics in helical coil pipes are the main contributors to the increased heat transfer.

III. PROBLEM FORMULATION

In the literature survey we found that so much work had been done to increase the heat transfer rate in heat exchanger. But there is less work has been done on heat transfer rate of square coil heat exchanger so. In my work I am trying to showing the CFD analysis of ZnO & TiO_2 Nanofluid with oil and ethylene glycol in square and helical coil heat exchanger by keeping in mind that Nano fluid should produce maximum heat transfer rate with minimum power consumption. Because some times in the process of improving the heat transfer coefficient we consume more power without knowing the economic cost. Consider the helical coil heat exchanger of PCD 60 mm of length 500 mm the pitch of the coil is 25 mm, the coil diameter is 10 mm & the material of coil is Copper. In my research I am using Zinc oxide and Titanium oxide as a Nano fluid with oil and ethylene glycol as its base fluid.

IV. CONCLUSION

The different boundary conditions are taken for helical coil and square coil heat exchanger for the numerical simulations. The numerical study considers the effect of Nano fluid Zinc Oxide, Titanium Dioxide and oil and ethylene glycol as its base fluid on the flow and heat transfer characteristics of tube. The thermal properties of fluid are lesser as compared to Nano fluid. We made a helical coil of 60 mm PCD and 10 mm tube diameter of length 500 mm, the Nano fluid with water as its base fluid is flow inside the tube.

REFERENCES

- [1] K. Abdul Hamid, W. H. Azmi, Rizalman Mamat, N. A. Usri and Gohalamhassan Najafi 2015, "Effect of Titanium Oxide Nanofluid Concentration on Pressure drop" ARPN Journal of Engineering and Applied Sciences, Volume 10, Page 7815-7820.
- [2] Hemasunder Banka, Dr. V. Vikram Reddy, M. Radhika 2016, "CFD Analysis of Shell and Tube Heat Exchanger using Titanium Carbide, Titanium Nitride and Zinc Oxide Nanofluid" International Journal of Innovations in Engineering and Technology, Special Issue, Page 315-322.
- [3] M. Balachandaran 2015, "Experimental and CFD study of a Helical Coil Heat Exchanger using Water as Fluid" International Journal of Mechanical and Production Engineering, Volume 3, Page 87-91.
- [4] Arvind Kumar Pathak, Yogesh Kumar Tembhurne, Mohit Gangwar 2017, "Comparison on CFD Analysis of Natural Fluid and Nano Fluid in Helical Coil Heat Exchanger" International Journal of Innovative Science and Research Technology, Volume 2, Page 83-90.
- [5] B. Chinna Ankanna, B. Sidda Reddy 2014, "Performance Analysis of Fabricated Helical Coil Heat Exchanger", International Journal of Engineering & Research, Volume 3, Page 33-39.
- [6] Karishma Jawalkar, Vijaykant Pandey, Poonam Wankhede 2018, "Comparison on Computational Fluid Dynamics Analysis of Zinc Oxide, Silicon Dioxide and Magnesium Oxide Nano-fluid using Oil as base fluid in Helical Coil Heat Exchanger", International Journal of Innovative Research in Science, Engineering & Technology, Volume 7, Page 2777-2786.
- [7] K. Palanisamy, P.C. Mukesh Kumar 2019, "Experimental investigation on convective heat transfer and pressure drop of cone helically coiled tube heat exchanger using carbon nanotubes/ water nanofluids", Elsevier – Heliyon 5.
- [8] Shiva Kumar et. al [9] have worked on both straight tube and helical tube heat exchanger. He has compared CFD results with the results obtained by the simulation of straight tubular heat exchanger of the same length under identical operating conditions. Results indicated that helical heat exchangers showed 11% increase in the heat transfer rate over the straight tube. Simulation results also showed 10% increase in nusselt number for the helical coils whereas pressure drop in case of helical coils is higher when compared to the straight tube.



- [9] T. Srinivas, A. Venu Vinod 2015, "Heat Transfer Enhancement using CuO/Water Nanofluid in a Shell and Helical Coil Heat Exchanger" Elsevier, Volume 127, Page 1271-1277.
- [10] Vinita Sisodiya, Dr. Ankur Geete 2016 "Heat Transfer analysis of Helical coil Heat Exchanger with Al₂O₃ Nanofluid" International Journal of Engineering and Technology, Volume 3, Page 366-370.
- [11] https://www.researchgate.net/figure/Physical-dimensions-of-tube-in-tube-helical-heat-exchanger_fig3_287510007<http://engglearning.blogspot.in/2011/03/helical-spring.html>
- [12] Sarit Kumar Das, Stephen U. S. Choi, Hrishikesh E Patel 2006, "Heat Transfer in Nano fluids -A Review" Heat Transfer Engineering, Volume 27.
- [13] Ram Kishn, Devendra Singh, 2020,"CFD Analysis of Heat Exchanger model using ansys fluent", International Journal of Mechanical Engineering & Technology, Volume 11 Issue 2, Page1-9.
- [14] Jaafar Albadr, Satinder Tayal, Mushtaq Alasadi 2013 —Heat transfer through heat exchanger using Al₂O₃ nanofluid at different concentrations Elsevier, Volume-1, Page 38-44.
- [15] Yamini Pawar, Ashutosh Zare, Ashish Sarode 2016, "Helically Coiled Tube with Different Geometry and Curvature Ratio on Convective Heat Transfer: A Review" International Journal of Innovative Research in Advanced Engineering, Volume-3, Page 19-23.
- [16] Kevin Kunnassery, Rishabh Singh, Sameer Jackeray 2017 "Experimental analysis of helical coil heat exchanger by using different compositions of nano fluids" International Journal of Innovative and Emerging Research in Engineering, Volume-4, Page 219-229.
- [17] Onkar Lathkar, Dr P.J. Bansod 2019, "CFD Analysis of Heat Transfer Enhancement in Heat Exchanger using Nanofluids", International Research Journal of Engineering and Technology, Volume-6, Page 4478-4482.
- [18] Fakoor-Pakdaman, M.A. Akhavan- Behabadi,P. Razi 2013, "An empirical study on the pressure drop characteristics of Nanofluid flow inside helically coiled tubes" International Journal of Thermal Sciences, Volume 65, Page 206-213.



10.22214/IJRASET



45.98



IMPACT FACTOR:
7.129



IMPACT FACTOR:
7.429



INTERNATIONAL JOURNAL FOR RESEARCH

IN APPLIED SCIENCE & ENGINEERING TECHNOLOGY

Call : 08813907089  (24*7 Support on Whatsapp)