



IJRASET

International Journal For Research in
Applied Science and Engineering Technology



INTERNATIONAL JOURNAL FOR RESEARCH

IN APPLIED SCIENCE & ENGINEERING TECHNOLOGY

Volume: 9 Issue: XI Month of publication: November 2021

DOI: <https://doi.org/10.22214/ijraset.2021.39050>

www.ijraset.com

Call:  08813907089

E-mail ID: ijraset@gmail.com

Comparison of RZ and NRZ Modulation Techniques by Varying Duty Cycle and Mach Zehnder Modulator

Sehrish Shabir¹, Monika Mehra²

¹M.Tech, ECE, RIMT University, Punjab

²Associate Professor, ECE Department, RIMT University, Punjab

Abstract: The aim of the research being undertaken is to examine the performance of advanced modulation formats such as RZ and NRZ modulation schemes and their long-haul repeater-free fibre-traffic (SMF). Modular transmission of signals by SMF has been highly attracted by several benefits, such as high chromatic dispersion tolerance (CD), simplicity of deployment and higher spectrum efficiencies. These are the essential performance indicators of an optimal modulation technique for the creation of multiplexed (DWDM) transmission networks of the future generation of dense wavelengths. Based on a comparison of the two modulation approaches I give my findings. To mimic both modulation schemes, OptiSystem software is employed. Eye diagram with measurement of the Q factor and BER is generated.

Keywords: Return to Zero, Non-Return to Zero, Eye Diagram, Bandwidth, BER, Q factor.

I. INTRODUCTION

Two kinds of signals are available, for example. Analog and digital. Analog and digital. In the form of binary zeros and ones, digital signals are shown. For transmitting digital data using digital signals, line coding methods such as unipolar, polar and bipolar are utilized. In these strategies, RZ and NRZ pulse forms are employed to decrease interference (ISI), by preventing distorted pulses from overlapping. This is the method known as line coding. Line coding is a digital signals digital data methodology. This coding allows the digital signal to map sequence of bits.

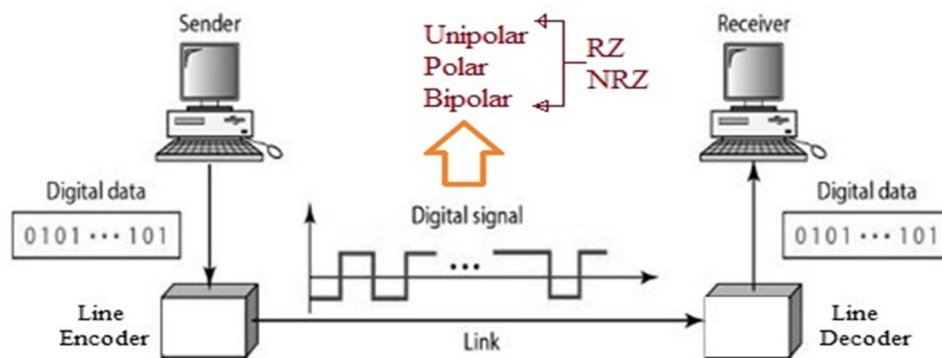

Fig 1: Line Encoding and Decoding

As seen in Fig 1, the line encoder codes the sender side lines. On the receiver side via line decoder, the identical digital signal is decoded. Line encoder transforms digital information to digital signal format and reverses line decoder.

Some of the Line coding characteristics are:

- 1) Reduces necessary bandwidth by employing a single signal pulse, sending numerous bits.
- 2) Makes the system bandwidth efficient.
- 3) It lowers the likelihood of mistake.
- 4) Avoiding long strings and zeros.
- 5) Failure to rectify technique such as bipolar coding.

A. Signaling Types

Three different sorts of signals exist: Unipolar, Polar and Bipolar.

Unipolar: Binary one ('1') is represented as a pulse presence in a single-polar signal type, and binary zero ('0') is represented as pulse lack. It is hence called "ON-OFF Keying." As mentioned below, it is divided into unipolar NRZ and unipolar RZ type.

Polar: One ('1') is encoded in the polar signal type with the positive pulse and the negative pulse is encoded with the zero ('0'). It is also classified as polar NRZ and polar RZ kinds.

Bipolar: three voltage levels, namely positive, negative and zero, are present in the bipolar signaling type. Binary '0' is represented as a null voltage neutral. Binary '1' is represented either by its places as a positive pulse or as a negative pulse. The Duobinary Signal is also known. Alternate positive and negative voltages are translated to binary ones. Therefore it is referred to as the reverse mark (AMI). The bipolar NRZ and Bipolar RZ are classified later on.

B. NRZ Pulse Shape / Non Return to Zero

Binary 1 is a positive voltage in NRZ line coding and does not return to zero throughout its bit period T_0 when the zero voltage is the binary 0.

1) Unipolar NRZ

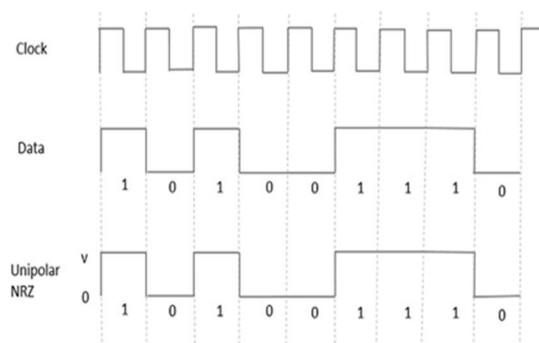

Fig 2: Unipolar NRZ coding

The binary '1' is represented in the unipolar NRZ by the 'V' pulse and the binary '0' by the lack of the pulse.

2) Polar NRZ

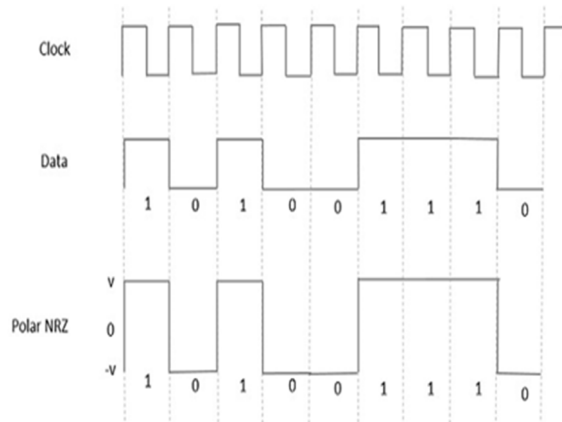

Fig 3: Polar NRZ coding

As seen in the image, binary '1' is represented in polar NRZ by a positive pulse with amplitude 'V' and a negative pulse with amplitude 'V' by a binary pulse.

3) *Bipolar NRZ*

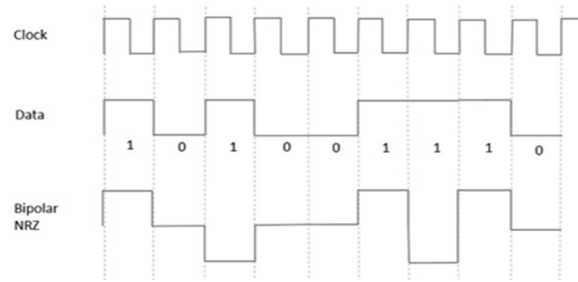

Fig 4: Bipolar NRZ coding

As illustrated in Fig 4, in bipolar NRZ, binary '0' is represented by zero voltage level. Every alternating binary ones are represented by series of positive and negative pulses with the same amplitude 'V'. Here pulse duration and symbol bit duration are equivalent.

4) *Advantages of NRZ line coding:* The advantages or benefits of NRZ line coding are as follows.

It is an easy line coding technology rather than RZ, as pulse does not come back to zero when binary data are mapped (1 and 0). Less bandwidth is required for unipolar NRZ signals.

No low frequency components in the signaling waveforms after cartooning are seen in polar NRZ and bipolar NRZ.

5) *Disadvantages of NRZ line coding :* The next inconvenience or disadvantage is the coding of the NRZ line.

In the signal shapes, the presence of low frequencies may lead to drop of signal waveforms.

No error correction process.

The lack of synchronization results in a long line of one and zeroes.

There is no clock.

C. *RZ Pulse Shape | Return to Zero*

In the RZ line coding, the "binary signal" pulse is returned to zero or ground potential after half a bit.

1) *Unipolar RZ*

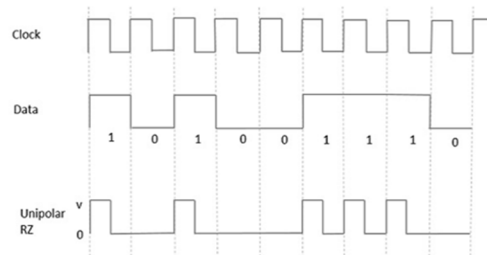

Fig 5: Unipolar RZ coding

Binary 1 is shown as high to low transition pulses, as seen in the picture. In the first half period, the pulse remains high for a whole bit and in the next half bit it returns to zero. Binary zero is shown as a pulse lack.

2) *Polar RZ*

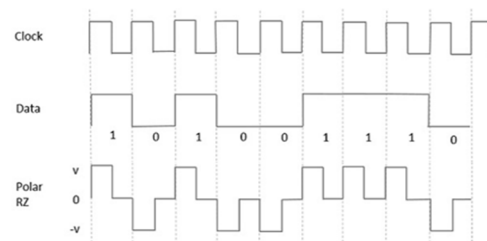

Fig 6: Polar RZ coding

Binary 1 is marked with pulses with positive to negative and binary '0' with pulses with negative to positive transitions, as demonstrated in polar signals. Initially, pulse is still high for binary '1' for the first half-bit pulse and low for the second half. For '0' binary, pulse remains low for the first half and high for the second half.

3) Bipolar RZ

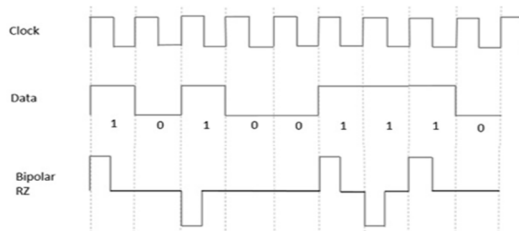

Fig 7: Bipolar RZ coding

Binary 0 is represented as zero voltage in this signalling style. Alternative binary pulses with a central transition from high->low and low->high correspondingly are represented by positive and negative pulses. For instance, the pattern of binary data is 10100110. In the initial half-bit period, binary '1' is shown with a positive voltage pulse, and then comes back to 0. The following is the binary 'zero,' which does not have voltage throughout the whole length of the bit. The pulse time here is half the bit duration of the symbol as compared to the type Bipolar NRZ.

4) *Advantages of RZ line Coding:* The advantages or benefits of RZ line coding are shown below.

It is a basic way of line coding.

No low-frequency components exist in polar RZ and bipolar RZ.

The waveform for bipolar NRZ/RZ is a low range compared to unipolar waveforms NRZ and NRZ.

In bipolar coding the signal drop does not occur. This line coding is therefore ideal for AC coupling data transfer.

This line coding approach allows for single mistake detection.

5) *Disadvantages of RZ line Coding:* The inconvenience or inconvenience of RZ Line coding follows.

Signal drop happens when the signal at 0 Hertz is not nil.

Two bandwidths occur with Unipolar/Polar RZ than with Unipolar/Polar NRZ.

Long strings of the one and zeros in the binary data cause loss of synchronization.

II. OBJECTIVES

The objective of my work is to compare the two modulation schemes, namely, RZ and NRZ. Comparison is made by the following ways:

With and Without Mach Zehnder Modulator.

Effect of Duty Cycle on the modulation schemes.

III. LITERATURE REVIEW

The earlier work on RZ/NRZ modulation schemes is abundant and there are new versions of these modulation schemes that are in use now a days. The earlier work on comparison of two techniques has usually proved RZ to be the better one when long distance and losses are concerned. But my work is mostly concerned with the effect of Duty Cycle on the two techniques and the results will surely help in saving a lot of power at the transmitter end.

IV. SOFTWARE REQUIREMENT

A. OptiSystem

OptiSystem offers the ability to develop, test and simulate optical links at the transfer layer for contemporary optical networks in the entire software design package. It is a system level simulator based on fiber-optic communication systems' realistic modelling. The optical component arrangement is controlled using an extensive graphical user interface (GUI). OptiSystem enables for the automation of almost all types of physical layer visual links and for analysis of a broad range of optical networks, including long-haul networks, local area networks and metropolitan area networks (MANs), (LANs).

V. SIMULATION MODEL

The various components used in my work are:

A. Pseudo Random Bit Sequence Generator

Pseudo-random binary series is a bi-sequence which, although it is constructed using a deterministic approach, is difficult to anticipate and displays statistical behaviour comparable to a really random sequence. PRBS generators are used for communications but also for encryption, modelling, correlation methods and flight time spectroscopy.

B. NRZ Pulse Generator

The NRZ pulse generator is used to produce a sequence of non-return pulses designed for the digital input signal. The NRZ pulse generator creates an electric signal based on the input of a bit sequence not returning to zero. Since the generator output is based on a small sequence, the generator with the input is connected to a user-defined bit sequence.

C. RZ Pulse Generator

The RZ pulse generator provides a zero pulsed sequence using a digital signal input.

D. CW Laser

Continuous light sources that do not constantly be pulsed. For example, for lasers but also for gases, the phrase is most commonly employed. Continuous functioning of the wave implies a laser is constantly pumped and continuously generates light. In longer scales the continuous laser production is more or less constant, although large power variations might occur due to mode beating and other laser noise.

E. Mach Zehnder Modulator

A Mach-Zehnder modulator is used to control the optical wave amplitude. The input manual is separated into two waveguide interferometric arms. For the wave that flows through this arm, a phase shift is begun if the tension crosses the arm. In combination, both arms transform the difference in phase between the two waves into amplitude modulation. The light recombines or does not recombine at all depends on the overall phase difference in the interferometer's output and hence results in variability in output power.

F. Optical Fiber

Optical fiber means medium and technology for the communication of information as light pulses on the glass or plastic beam or fibre. In fibre optics the networking of long distance and high performance data is used. The use of fibre optic cables is predicated on various advantages over copper lines, including increased bandwidth and quicker transmission. Much of this fibre may be found on a fiber optic cable. The centre of the glass fibre is another layer called cladding. The wrapping is covered by a so-called buffer tube, and for the single strand the wrapping layer is the last layer of protection.

G. EDFA

In terms of communication with long-range optical fibres, Erbium-doped fibre amplifiers are by far the main fibre amplifier; they can efficiently amplify light in the area of 1.5 μm , in which telecom fibres have low losses. A rare earth-doped fibre is the core component of a fibre amplifier, which may be amplified by stimulated emission, if fed optically into a fibre with another light.

H. Eye Diagram Analyzer

Eye diagrams are an easily understood visual depiction of electric or optical digital signals. The appearance of the eye may be used to assess the quality of signal, such as periods of increase and fall, the degree of interference of symbols, noise and rash. By dividing a communication signal into two-bit (or symbol), and overlapping it, the wave-form of a communication signal, such as a non-return to zero (NRZ) and return to zero (RZ) may be translated into a diagram. For example, the shape of an NRZ sign with moderate ISI is divided into segments with a half-bit left-hand interval and a full bit centre, with a half-bit right-hand interval. The graphic has a major advantage over the linear signal representation by compactly displaying all feasible bit transitions. Differences in these transitions from their ideal location constitute the jitter in the signal. The periodic sampled bit (or symbol) of the eye scheme overlaps into a single sampling moment to visualise the ISI and the noise during the sampling process.

VI. RESULTS AND OBSERVATIONS

We have divided the results into two parts. In the first part, importance of Mach Zehnder Modulator is demonstrated. In the second part, effect of duty cycle on both techniques is studied.

A. When no Mach Zehnder Modulator is Used

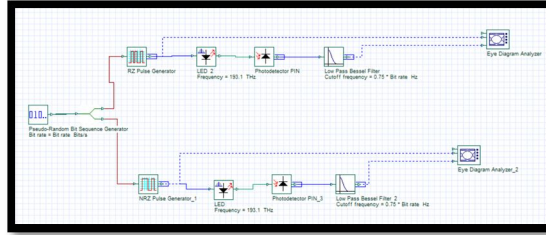

Fig 8: Simulation Setup Setup with no Mach Zehnder Modulator

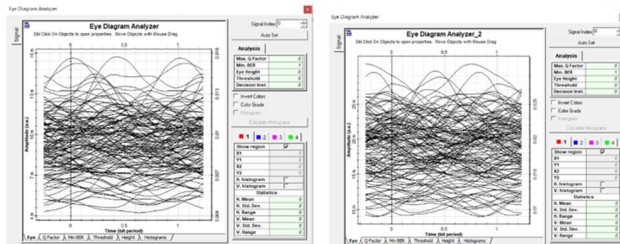

Fig 9: Eye Diagram Results

There is total distortion and input is totally lost. So we cannot send the data this way no matter we use RZ or NRZ Modulation.

B. When Mach Zehnder Modulator is Used

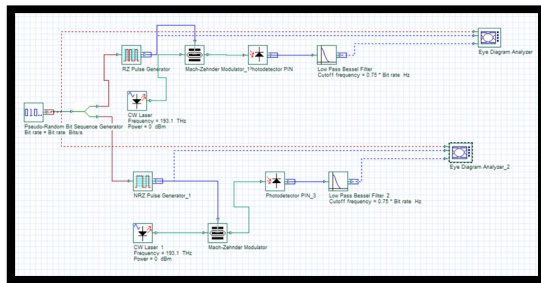

Fig 10: Simulation Setup with Mach Zehnder Modulator

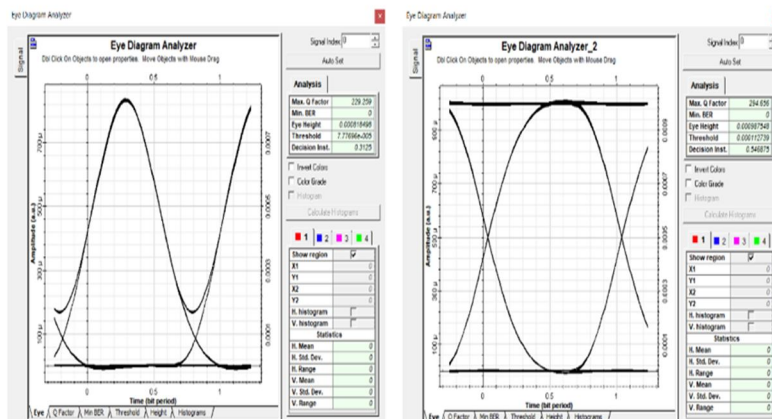

Fig 11: Eye Diagram Results

Table 1
Q Factor and BER Values with Modulator

S.No	Modulation Type	Eye Diagram	
		Max Q Factor	Min BER
1	RZ	229	0
2	NRZ	294	0

After the introduction of Mach Zehnder Modulator, distortion reduces significantly and data received at output is highly accurate. This is because the data that is to be sent finds a carrier that helps in its transmission. So we find out that no matter which modulation technique we use, if we don't use a modulator, the data cannot be transmitted practically. Mach Zehnder Modulator helps in transmitting the data to larger distance.

Looking at the Table 1, we find that when Mach Zehnder modulator is used both for RZ and NRZ, NRZ technique performs better for the same other parameters. The reason for this is the more bandwidth required for the RZ technique that spreads the power more than that in NRZ. As a result the spectral power in RZ is less than that of NRZ

C. Changing Duty Cycle

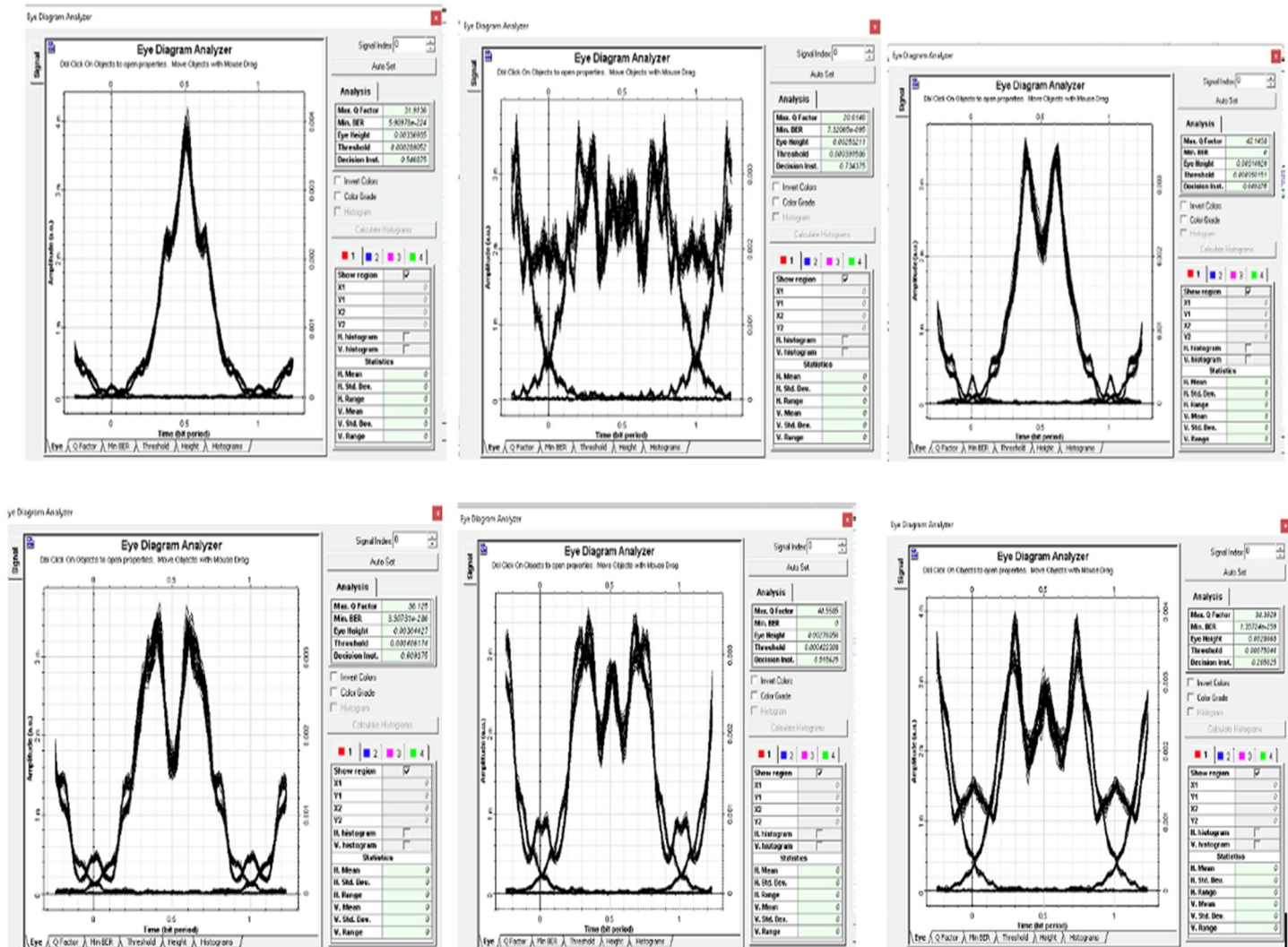

Fig 12: Eye Diagram Results

Table 2:
Q Factor Values at Different Duty Cycles

Technique Used	Duty Cycle	Q factor
RZ	0.5	31.91
	0.6	42.14
	0.7	36.12
	0.8	40.55
	0.9	34.29
	1	20.01
NRZ	0.5	23.4
	0.6	31.67
	0.7	25.87
	0.8	29.65
	0.9	24.76
	1	21.39

By varying the Duty Cycle of the pulse in RZ and NRZ modulators, I discovered that the ideal Duty Cycle value is 0.6, as BER is minimal in this scenario and Q factor is maximum. The better BER and Q factor is found for the NRZ technique. It can be attributed to the fact that NRZ technique requires less power for transmission as compared to RZ modulation technique because of low bandwidth and high power spectral density.

VII. CONCLUSION

In this paper, we have compared the RZ and NRZ modulation schemes and found that NRZ performs better than RZ. Moreover, the optimum value of Duty Cycle was also found to be 0.6 and on increasing and decreasing the duty cycle from that optimum value, BER and Q factor value deteriorated.

REFERENCES

- [1] Sen Zhang, "Advanced Optical Modulation Formats in high-speed Lightwave system," www.ittc.ku.edu/publications/documents_consulted_on_03/01/2008
- [2] Peter J. Winzer, and Rene-Jean Essiambre, "Advanced optical modulation formats," Proceedings of the IEEE, vol. 94, pp. 952-985, 2006.
- [3] A. Gnauck, G. Raybon, S. Chandrasekhar, J. Leuthold, C. Doerr, L. Stulz, A. Agarwal, S. Banerjee, D. Grosz, S. Hunsche, A. Kung, A. Marhelyuk, D. Maywar, M. Movassaghi, X. Liu, C. Xu, X. Wei, and D. Gill, "2.5 Tb/s 64 * 42.7 Gb/s Transmission Over 40*100 km NZDSF using RZ-DPSK Format and All-Raman- Amplified Spans," OFC, 2002. Paper FC2.
- [4] <https://www.rfwireless-world.com/Terminology/Comparison-between-RZ-and-NRZ-Pulse-Shapes.html>



10.22214/IJRASET



45.98



IMPACT FACTOR:
7.129



IMPACT FACTOR:
7.429



INTERNATIONAL JOURNAL FOR RESEARCH

IN APPLIED SCIENCE & ENGINEERING TECHNOLOGY

Call : 08813907089  (24*7 Support on Whatsapp)