



# IJRASET

International Journal For Research in  
Applied Science and Engineering Technology



---

# INTERNATIONAL JOURNAL FOR RESEARCH

IN APPLIED SCIENCE & ENGINEERING TECHNOLOGY

---

**Volume:** 10    **Issue:** VI    **Month of publication:** June 2022

**DOI:** <https://doi.org/10.22214/ijraset.2022.43899>

[www.ijraset.com](http://www.ijraset.com)

Call:  08813907089

E-mail ID: [ijraset@gmail.com](mailto:ijraset@gmail.com)

# A Comprehensive Review on Crop Disease Classification using Machine Learning Technique

Priyanka Bande<sup>1</sup>, Mr. Kranti Dewangan<sup>2</sup>

<sup>1, 2</sup>Computer Science Department, Sri Rawatpura University

**Abstract:** With migrating populations towards cities and global urbanization, there arises a need to automate certain sections of agriculture. Precision agriculture has emerged as an active areas of research in which computational and data processing techniques are being applied in the domain of agriculture. One of the most common and menacing problems which farmers face is crop diseases which result in malnourishing the actual crop and in some cases completely destroying the crop. Hence, machine learning and deep learning based techniques are being extensively studied and explored to design systems which can identify diseases among plants, automatically. Crop disease identification is a relatively challenging task keeping in mind the similarity among the textures of plants and the variations among plants of the same category, blurring and noise effects appearing in images typically captured by unmanned aerial vehicles (UAVs). This paper presents a comprehensive review on image pre-processing and machine learning based techniques for automated classification of crops diseases. The fundamental mechanism of noise removal along with noise sources in images have been cited and explained. The basics of machine learning based classifiers applied to image classification have also been discussed. Salient features of existing techniques along with the research gap have been clearly highlighted. The research gaps identified in existing work allows future researchers in leveraging the limitations of existing approaches and devising novel methods. Finally the evaluation metrics to evaluate the performance of existing work have been presented for comparative performance evaluation.

**Keywords:** Crop Disease Identification, Noise Filtering, Machine Learning, Deep Learning, Classification Error, Accuracy.

## I. INTRODUCTION

The agriculture sector has been witnessing tremendous technological advancements with the rise in digital infrastructure. The use of high end technology driven methods have been rampant in this domain. The crop quality is a major aspect of crop harvesting. But there are many factors that lead to the diminishing quality of crops. Disease is one such problem that is commonly faced while cultivation of crops. Precise detection of these diseases can help in preventing damage to the crops and disease free cultivation [1]. With the help of machine learning, the challenges in the agricultural domain can be easily mitigated and solved. There happen to be certain areas where the traditional ways of farming methods don't work effectively. Crop Diseases provide major hindrance towards successful and healthy cultivation of crops. Manual manpower also fails in disease detection when the quantity of the crop is huge. This is where the machine learning methods can greatly contribute in accurate and proper classification of crop and disease [2]-[3]. The concept of automatic detection and classification of diseases can play a beneficial role in crop disease management. Lesser the disease, higher will be the yield of crops. One of the major challenges that exist in detection of diseases is crops and diseases tend to have similar appearance, colour and texture. Henceforth accurate classifications of disease have to be carried out for the precise disease detection [4].

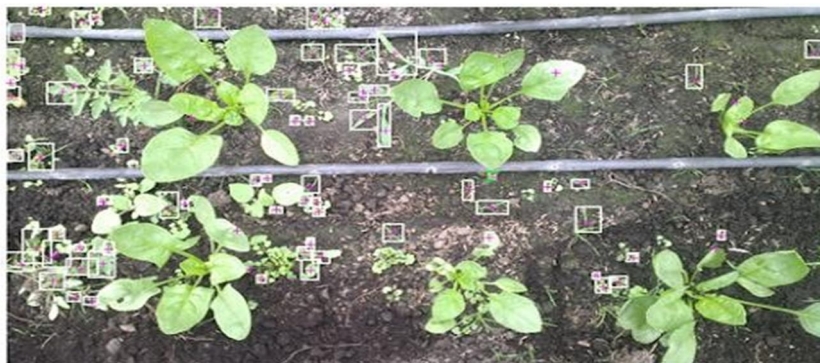

Fig.1 A typical illustration of crop disease identification

Machine learning based approaches provide a vast range of methods for accurate classification with high accuracy. With the advancement in technology, the concept of precision agriculture has gained quite a good prominence [5]. The disease needs to effectively classified and separated from the crop production for quality yield of crops. Machine learning methods have emerged as robust solution for crop and disease classification. It involves the use of artificial intelligence and machine learning methods for precise classification of crop and disease. Disease detection and management has to be done accurately for its detection. The classification methods that are used in machine learning provide very high accuracy [6]. Manual man power can be less cost effective and also less accurate when the amount of crop disease detection is huge.

The use of supervised learning methods as a part of implementing artificial intelligence concepts can go a long way in quality crop cultivation with high yields. The disease classification can be facilitated accurately as the identification of different types of disease can be easily done using machine learning where human intervention can take a long time. The growth of diseases is rampant on farm lands and not quite easily recognizable and they feed on the healthy crops [7]. So, automated methods can revolutionize this aspect of crop disease detection and aid in precision agriculture with the use of efficient machine learning backed models and methods. It would entail high yield, cost effectiveness and quality produce [8].

There have been several models which have been used to classify crops and diseases. A detailed analysis of contemporary methods along with the findings has been presented in table I.

TABLE I  
NOTEWORTHY CONTRIBUTION IN THE DOMAIN

Authors	Technique	Advantages	Limitations
Anter et al.	Fuzzy C-means clustering.	Disease boundaries clearly enhanced with labelled Fuzzy training.	Saturation of performance after which adding training data doesn't improve performance.
Bakhshipour et al.	Gray level and moment feature based supervised classifier	Background enhancement, with high contrast difference between crop and background.	Relatively low accuracy and sensitivity, due to computation of moment features only.
Sospedra et al.	Ensemble classifier	Suitable for both low and high resolution images.	Relatively higher computational complexity.
Dasgupta et al.	Bayesian classifier	Clear segmentation of vessels from the background pixels	Relatively low sensitivity and saturation of performance with adding data to training set.
Shruthi et al.	Fuzzy Classifier	Relatively high accuracy.	Relative high computational complexity with increasing features and performance saturation for less number of features.
Chen et al.	GLCM based features with PCA	Low computational complexity.	Relatively low accuracy owing to lesser number of features extracted.
Jin et al.	Combination of CNN for boundary identification with Bayes Net for classification.	Relatively high accuracy.	Not applicable for low resolution images.
Abouzahir et al.	Histogram oriented gradients based deep neural network.	Robust multi-variate classifier.	Relatively low accuracy
Le et al.	Deep-learning-based approach using RCNN.	Relatively high accuracy with low and high level features extracted through hidden layers of Deep Neural Network.	Relatively high computational complexity.
Alam et al.	Naïve Bayes Classifier	Probabilistic approach robust for overlapping features.	Background enhancement and noise removal not explored.
Sabzi et al.	ANN-PSO hybrid.	Hybrid model of ANN and particle swarm optimization used to update network weights.	Experimental results validated for small dataset.

## II. THEORITICAL BACKGROUND

Automated crop-disease classification has gained prominence with advanced image processing techniques coupled with machine learning. Automated detection is generally based on three major steps which are image processing and data preparation, feature extraction and final classification. Each of these processes are discussed in this section:

### A. Image Processing

Prior to computing important parameters or feature of the fundus image, which lays the foundation for the final classification, it is necessary to process the image for the following reasons:

- 1) *Illumination Correction*: In this part, the inconsistencies in the image illumination are corrected so as to make the image background uniform and homogenous. Illumination inconsistencies occur due to capturing the image from different angles under inconsistent lighting [9]. Inconsistencies in the illumination can be caused due to the position and orientation of the source, the non-homogeneity of wavelengths of the source, the nature of the surface such as smoothness, orientation and material characteristics and finally the characteristics of the sensing device such as resolution, capturing capability and sensitivity [10]. Typically, illumination correction is done based on the computation of the correlation co-efficient given by:

$$Corr2(x, y) = \frac{O(x,y) - D(x,y)}{B(x,y) - D(X,y)} \cdot N \tag{1}$$

Here,

Corr2 represents the 2 dimensional cross correlation,

is termed as the normalizing factor

represents the original image

D represents the dark image

B represents the bright image

The normalizing term 'N' is computed as:

$$N = \frac{\text{mean}\{O(x,y)\}}{\frac{O(x,y) - D(x,y)}{B(x,y) - D(X,y)}} \tag{2}$$

Here,

Mean represents the average value of the random variables (x,y) which are the pixel values of the images.

Another common approach is the use of low pass filtering which considers the inconsistencies to occur in the low spectral range of the image and are filtered out using a low pass filter (LPF), given by:

$$N_l = (x, y) - L\{O(x,y)\} + \text{mean}[LPF\{O(x, y)\}] \tag{3}$$

Here,

$N_l$  represents the normalized image

O represents the original image

LPF stands for the low pass filter

- 2) *Segmentation and Normalization*: Segmentation is done primarily to separate the area of interest from the actual image. The segmentation is generally done adopting the sudden change in pixel characteristics given by the gradient:

$$G = \max(r, x_0, y_0) \left| K_\sigma(r) \frac{\partial}{\partial r} \oint_{r, x_0, y_0}^{r, x_f, y_f} \frac{I(x,y)}{2\pi r} ds \right| \tag{4}$$

Here,

G is the gradient (x,y) are the image pixels r represents the image radius ds is the surface integral K is a typically a Gaussian kernel

The gradient based method allows to find the maximum change in the pixel intensities to perform the thresholding so as to separate out regions from an image. Further the inpainting can be performed based on the neighbouring pixel information and the stochastic characteristics utilizing the fact that image regions generally comprise of highly redundant values. Considering the region to be inpainted as S and its boundary to be  $\delta S$ , inpainting is performed by computing the stochastic parameters around  $\delta S$  and gradually moving towards S as:

$$\frac{\partial I}{\partial (x,y)} = \nabla(\Delta I) \cdot \nabla^o I \tag{5}$$

Here,  $\frac{\partial I}{\partial (x,y)}$  represents the partial derivative of the Image w.r.t. x & y

$\Delta I$  represents the Laplacian of I

$\nabla^o$  represents the orthogonal gradient.

Finally the optical nerve is normalized to compute the CRD of the image.

### B. Feature Extraction

1) *Feature Extraction*: The classification of glaucoma is to be done using any automated classifier but machine learning classifiers need to be fed with image features or parameters which can help the classifier to learn the differences between the diseases and non-diseases [11]. Typically, the features care stochastic features of the image such as the mean, variance, standard deviation, skewness, correlation etc. The feature extraction is critically important since the classifier would decide based on the feature vector whether any new image is a disease or not. Apart from the statistical features, some features can also be computed in the transform domain. Some of the common statistical features for grayscale or RGB images are [12]:

$$M \text{ or } E_1 = \frac{1}{N} \sum_{i,j}^N f_{i,j} \tag{6}$$

$$sd = \sqrt{\frac{1}{N} \sum_{i,j}^N (f_{i,j} - E_1)^2} \tag{7}$$

$$v = \frac{1}{N} \sum_{i,j}^N (f_{i,j} - E_1)^2 \tag{8}$$

$$k = \sqrt[3]{\frac{1}{N} \sum_{i,j}^N (f_{i,j} - E_1)^3} \tag{9}$$

Here,

$f_i$  corresponds to the  $i^{\text{th}}$  colour component for pixel j

M or  $E_1$  represent the mean or the first moment of expectation for the image s.d. represents the standard deviation v represents the variance

k represents the skewness

For the features in the transform domain, one of the most predominantly used features are the Gabor filters which essentially perform the convolution of the Gabor wavelet and the image under consideration given by:

$$g(x, y) = \frac{1}{2\pi s_x s_y} e^{[-\frac{1}{2}(\frac{x^2}{s_x^2} + \frac{y^2}{s_y^2}) + 2\pi j C_x]} \tag{10}$$

Here,

$(x, y)$  represent the Gabor features

$s_x$  and  $s_y$  are the scaling parameters

$C_x$  represents the central frequency of the contour

Apart from Gabor features, shape features can be also useful in case of images containing regular shapes such as straight lines, circles, rings or discs etc. Another useful feature extraction method is the computation of histogram oriented gradient or the HOG features [13]. The idea behind HOG features is the fact that images can be differentiated based on image intensity histograms and gradients from which the term HOG derives its name. They differential gradients along x and y are computed as [14]:

$$g_x = \frac{\partial f(x,y)}{\partial x} = \frac{f(x+\Delta,y) - f(x,y)}{(x+\Delta) - x} \tag{11}$$

$$g_y = \frac{\partial f(x,y)}{\partial y} = \frac{f(y+\Delta,x) - f(x,y)}{(y+\Delta) - y} \tag{12}$$

Here,

$g_x$  represents the gradient along x

$g_y$  represents the gradient along y

$\Delta$  represents an incremental change

It is often customary to take the incremental change to be unity for HOG features.

The gradient vector's magnitude is a function of the orientation angle  $\theta$  and is computed as:

$$G_\theta = (g_x, g_y, \theta) \tag{13}$$

$$|G_\theta| = \sqrt{g_x^2 + g_y^2} = f(\theta) \tag{14}$$

Here,

$|G_\theta|$  represents the magnitude of the composite gradient

$\theta$  is the orientation angle in the azimuth calculated in the range of  $(-\pi, \pi)$  or  $(0, 2\pi)$ .

Another prominent feature extraction technique is the computation of the gray level co-occurrence matrix (GLCM) features which tries to estimate the probability of occurrence of a pixel 'i' w.r.t. a pixel 'j' at a separation 'l'. Thus it's a joint probability distribution based feature extraction technique over the x-y plane of the image. The GLCM normalization co-efficient 'N' is defined as [15]:

$$N_{i,j} = \frac{X_{i,j}}{\sum_{i=0}^{K-1} \sum_{j=0}^{K-1} X_{i,j}} \tag{15}$$

Here, i and j are the pixel indices

$X_i$  is the pixel value

Some of the probabilistic features computed for GLCM features apart from statistical features like mean, variance, standard deviation etc are:

Entropy: It is the average amount of information contained in a random variable with elements or entities having associated probabilities of occurrence. It is defined as:

$$E = -\sum_{x,y} P(x,y) \log_2 P(x,y) \tag{16}$$

Here,

E stands for the entropy

I is the image

P is the probability of occurrence of pixel I w.r.t. pixel j.

The entropy value helps to compress images and is also used for noise removal or inpainting since redundancies of the image can be found and discarded without losing vital image information. The level of similarity is also computed based on the joint probability of occurrence of pixels given by:

$$H = \sum_{i,j}^{M,N} \frac{P_{i,j}}{1-(i-j)^2} \tag{17}$$

Here,

H stands for Homogeneity

P stands for the joint probability .

The value of homogeneity quantifies the nature of distribution of the pixel values which bear similarity or dissimilarity. A similar parameter evaluating the closeness of stochastic properties of pixel regions is the two dimensional correlation given by:

$$Corr_{2D} = \sum_{i,j}^{M,N} \frac{(i-m_x)(j-m_y)P_{x,y}}{sd_x sd_y} \tag{18}$$

Here,

$Corr_{2D}$  is the two dimensional correlation

M and N are the number of pixels along x and y

$m_x$  is the mean along x

$m_y$  is the mean along y

$sd_x$  is the standard deviation along x

$sd_y$  is the standard deviation along y

The GLCM features thus help to evaluate the co-occurrence of the pixel values in an image and hence can be used to judge the similarity or redundancies in the image pixel regions.

### C. Classification

Based on the image processing and feature extraction, the classification is done. Automated classification requires training a classifier with the pre-defined and labelled data set and subsequently classifying the new data samples. Off late machine learning based classifiers are being used for the classification problems. Machine learning based classifiers are typically much more accurate and faster compared to the conventional classifiers. They render more robustness to the system as they are adaptive and can change their characteristics based on the updates in the dataset. The common classifiers which have been used for the classification of glaucoma cases are:

1) *Regression Models:* In this approach, the relationship between the independent and dependent variable is found utilizing the values of the independent and dependent variables. The most common type of regression model can be thought of as the linear regression model which is mathematically expressed as:

$$y = \theta_1 + \theta_2 x \tag{19}$$

Here, x represents the state vector of input variables y represents the state vector of output variable or variables.

$\theta_1$  and  $\theta_2$  are the co-efficients which try to fit the regression learning models output vector to the input vector. Often when the data vector has large number of features with complex dependencies, linear regression models fail to fit the input and output mapping. In such cases, non-linear regression models, often termed as polynomial regression is used. Mathematically, a non-linear or higher order polynomial regression models is described as:

$$y = \theta_0 + \theta_1 x^3 + \theta_2 x^2 + \theta_3 x \tag{20}$$

Here, x is the independent variable y is the dependent variable

$\theta_1, \theta_2 \dots \dots \theta_n$  are the co-efficients of the regression model.

Typically, as the number of features keep increasing, higher order regression models tend to fit the inputs and targets better. A typical example is depicted in figure 2

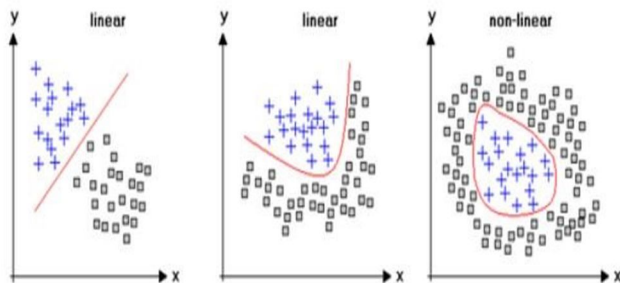

Fig. 2 Linear and Non-Linear Regression fitting

2) *Support Vector Machine (SVM)*: This technique works on the principle of the hyper-plane which tries to separate the data in terms of 'n' dimensions where the order of the hyperplane is (n-1). Mathematically, if the data points or the data vector 'X' is m dimensional and there is a possibility to split the data into categories based on 'n' features, then a hyperplane of the order 'n-1' is employed as the separating plane. The name plane is a misnomer since planes corresponds to 2 dimensions only but in this case the hyper-plane can be of higher dimensions and is not necessarily a 2-dimensional plane. A typical illustration of the hyperplane used for SVM based classification is depicted in figure 3 [16].

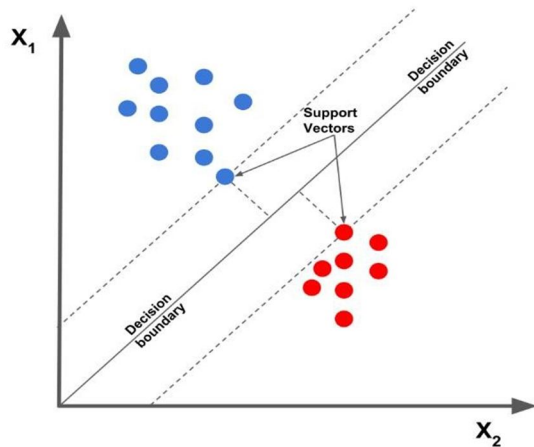

Fig. 3 Separation of data classes using SVM [15]

The selection of the hyperplane H is done on the basis of the maximum value or separation in the Euclidean distance d given by:

$$d = \sqrt{x_1^2 + \dots + x_n^2} \tag{21}$$

Here,

x represents the separation of a sample space variables or features of the data vector, n is the total number of such variables d is the Euclidean distance

The (n-1) dimensional hyperplane classifies the data into categories based on the maximum separation. For a classification into one of 'm' categories, the hyperplane lies at the maximum separation of the data vector 'X'. The categorization of a new sample 'z' is done based on the inequality:

$$d_x^z = (d_{c^z_1}, d_{c^z_2} \dots d_{c^z_m}) \tag{22}$$

Here,  $d_x^z$  is the minimum separation of a new data sample from 'm' separate categories

$d_{c^z_1}, d_{c^z_2} \dots d_{c^z_m}$  are the Euclidean distances of the new data sample 'z' from m separate data categories.



3) *Neural Networks*: Owing to the need of non-linearity in the separation of data classes, one of the most powerful classifiers which have become popular is the artificial neural network (ANN). The neural networks are capable to implement non-linear classification along with steep learning rates [17]. The neural network tries to emulate the human brain’s functioning based on the fact that it can process parallel data streams and can learn and adapt as the data changes. This is done through the updates in the weights and activation functions. The mathematical model of the neuron is depicted in figure 4.

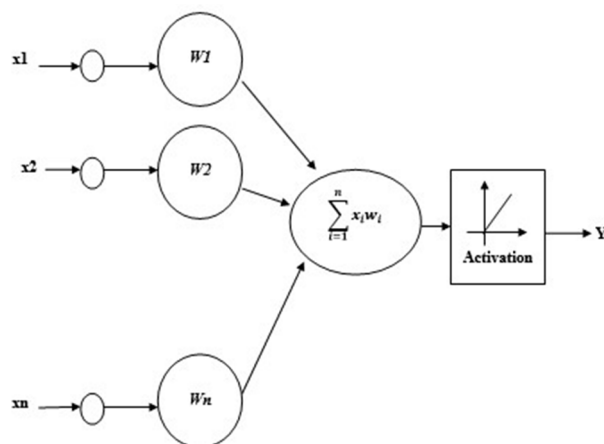

Fig. 4 Mathematical Model of Single Neuron

The mathematical equivalent of an artificial neuron is depicted in figure 4 where the output can be given by:

$$y = (\sum_{i=1}^n x_i w_i + b) \tag{23}$$

Here,  $x$  denote the parallel inputs  $y$  represents the output  $w$  represents the bias

$f$  represents the activation function

The neural network is a connection of such artificial neurons which are connected or stacked with each other as layers. The neural networks can be used for both regression and classification problems based on the type of data that is fed to them. Typically the neural networks have 3 major conceptual layers which are the input layer, hidden layer and output layer. The parallel inputs are fed to the input layer whose output is fed to the hidden layer. The hidden layer is responsible for analysing the data, and the output of the hidden layer goes to the output layer. The number of hidden layers depends on the nature of the dataset and problem under consideration. If the neural network has multiple hidden layers, then such a neural network is termed as a deep neural network. The training algorithm for such a deep neural network is often termed as deep learning which a subset of machine learning is. Typically, the multiple hidden layers are responsible for computation of different levels of features of the data. Several categories of neural networks such as convolutional neural networks (CNNs), Recurrent Neural Network (RNNs) etc. have been used as effective classifiers.

The performance metrics of the classifiers are generally computed based on the true positive (TP), true negative (TN), false positive (FP) and false negative (FN) values which are used to compute the accuracy (Ac), sensitivity(Se), Recall (Re), Precision and Recall of the classifier, mathematically expressed as [18]:

$$Ac = \frac{TP+TN}{TP+TN+FP+FN} \tag{24}$$

$$Se = \frac{TP}{TP+FN} \tag{25}$$

$$Recall = \frac{TP}{TP+FN} \tag{26}$$

$$Precision = \frac{TP}{TP+FP} \tag{27}$$

$$F - Measure = \frac{2 \cdot Precision \cdot Recall}{Precision + Recall} \tag{28}$$

The aim of any designed approach is to attain high values of accuracy of classification along with other associated parameters. The computation complexity of the system often evaluated in terms of the number of training iterations and execution time is also a critically important metric which decides the practical utility of any algorithm on hardware constrained devices.

### III. CONCLUSION

This paper introduces the need for precision agriculture along with its applications in the domain of automated classification of crop and diseases. The working of automated classifiers along with their attributed and dependence on feature extraction has been explained in detail. Different stages of the image processing and segmentation have been enlisted. The significance of different image features and extraction techniques have been clearly mentioned with their utility and physical significance. Various machine learning based classifiers and their pros and cons have been highlighted. The mathematical formulations for the feature extraction and classification have been furnished. A comparative analysis of the work and results obtained has been cited in this paper. It can be concluded that image enhancement and feature extraction are as important as the effectiveness of the automated classifier, hence appropriate data processing should be applied to attain high accuracy of classification.

### REFERENCES

- [1] S.Haug J.Ostermann, "Plant classification system for crop /disease discrimination without segmentation", IEEE Winter Conference on Applications of Computer Vision, IEEE 2014, pp. 1142-1149.
- [2] A. Zhang, X.Wei X. "A review on disease detection using ground-based machine vision and image processing techniques. Computers and Electronics in Agriculture", Elsevier 2019, 158, pp: 226-240
- [3] AM Anter, AE Hassenian, D Oliva, "An improved fast fuzzy c-means using crow search optimization algorithm for crop identification in agricultural", Expert Systems with Applications, Elsevier 2019, vol.118, pp.340-354.
- [4] A.Bakhsipour, A.Jafari A, S.Nassiri. D.Zare, "Disease segmentation using texture features extracted from wavelet sub-images", Biosystems Engineering, Elsevier 2017, vol.157, pp.1-12.
- [5] J Torres-Sospedra, P Nebot, "Two-stage procedure based on smoothed ensembles of neural networks applied to disease detection in orange groves", Biosystems Engineering, Elsevier 2014, vol.123, pp.40-55.
- [6] I Dasgupta, J Saha, P Venkatasubbu, "AI crop predictor and disease detector using wireless technologies: a smart application for farmers", Arabian Journal for Science and Engineering, Springer 2020, vol.45, pp.11115– 11127.
- [7] U. Shruthi, V. Nagaveni and B. K. Raghavendra, "A Review on Machine Learning Classification Techniques for Plant Disease Detection," 2019 5th International Conference on Advanced Computing & Communication Systems (ICACCS), 2019, pp. 281-284.
- [8] Y Chen, Z Wu, B Zhao, C Fan, S Shi, "Disease and corn seedling detection in field based on multi feature fusion and support vector machine" Sensors, MDPI 2021, vol.21, no.12, pp.1-18.
- [9] X. Jin, J. Che and Y. Chen, "Disease Identification Using Deep Learning and Image Processing in Vegetable Plantation," in IEEE Access 2021, vol. 9, pp. 10940-10950.
- [10] S Abouzahir, M Sadik, E Sabir, "Bag-of-visual-words-augmented Histogram of Oriented Gradients for efficient disease detection", Biosystems Engineering, Elsevier 2021, vol.202, pp. 179-194.
- [11] V. N. Thanh Le, G. Truong and K. Alameh, "Detecting diseases from crops under complex field environments based on Faster RCNN," 2020 IEEE Eighth International Conference on Communications and Electronics (ICCE), 2021, pp. 350-355.
- [12] M. Alam, M. S. Alam, M. Roman, M. Tufail, M. U. Khan and M. T. Khan, "Real-Time Machine-Learning Based Crop/Disease Detection and Classification for Variable-Rate Spraying in Precision Agriculture," 2020 7th International Conference on Electrical and Electronics Engineering (ICEEE), 2020, pp. 273-280.
- [13] S Sabzi, Y Abbaspour-Gilandeh, "Using video processing to classify potato plant and three types of disease using hybrid of artificial neural network and particle swarm algorithm", Measurement, Elsevier 218, vol.126, pp.Pages 22-36.
- [14] Tin-Yau Kwok and Dit-Yan Yeung, "Constructive algorithms for structure learning in feedforward neural networks for regression problems," in IEEE Transactions on Neural Networks, vol. 8, no. 3, pp. 630-645.
- [15] F.Ahmed, Al-Mamun, A.Bari, E.Hossain, "Classification of crops and diseases from digital images. A support vector machine approach Journal of Crop Production", Elsevier 2013, vol.40, pp: 98-104.
- [16] S. S. Athani and C. Tejeshwar, "Support Vector Machine-Based Classification Scheme of Maize Crop," 2017 IEEE 7th International Advance Computing Conference (IACC), 2017, pp. 84-88.
- [17] P. Lottes, J. Behley, N. Chebrolu, A. Milioto and C. Stachniss, "Joint Stem Detection and Crop-Disease Classification for Plant-Specific Treatment in Precision Farming," 2018 IEEE/RSJ International Conference on Intelligent Robots and Systems (IROS), 2018, pp. 8233-8238.
- [18] S. Haug, A. Michaels, P. Biber and J. Ostermann, "Plant classification system for crop /disease discrimination without segmentation," IEEE Winter Conference on Applications of Computer Vision, 2014, pp. 1142-1149.



10.22214/IJRASET



45.98



IMPACT FACTOR:  
7.129



IMPACT FACTOR:  
7.429



# INTERNATIONAL JOURNAL FOR RESEARCH

IN APPLIED SCIENCE & ENGINEERING TECHNOLOGY

Call : 08813907089  (24\*7 Support on Whatsapp)