



IJRASET

International Journal For Research in
Applied Science and Engineering Technology



INTERNATIONAL JOURNAL FOR RESEARCH

IN APPLIED SCIENCE & ENGINEERING TECHNOLOGY

Volume: 10 Issue: IV Month of publication: April 2022

DOI: <https://doi.org/10.22214/ijraset.2022.41128>

www.ijraset.com

Call:  08813907089

E-mail ID: ijraset@gmail.com

Design and Fabrication of Agricultural Sprayer

Prashant Kumar S. Pal¹, Rahul R. Pal², Vikas D. Prajapati³, Yuvraj R. Pandey⁴, Sajid Shaikh⁵

^{1, 2, 3, 4} Student, ⁵ Assistant Professor, Department of Mechanical Engineering Them college of Engineering, Boisar, East, Boisar - Palghar Rd, Chilhar, Maharashtra 401501

Abstract: *The spraying is traditionally done by labour carrying backpack type sprayer which requires more human effort. The weeding is the generally done with the help of Bulls becomes for small land farmers. Similarly the seed sowing application is also done with the help of bulls, which in the present age is time consuming and laborious. So to overcome these above problems a machine is developed which will be beneficial to the farmer for the spraying and weeding operation along with the seed sowing application. A multifunction device will come in handy that can be put to use in different stages of farming as per requirement.*

I. INTRODUCTION

Agriculture is one of the major sectors of the Indian economy. It is present in the country for thousands of years. Over the years it has developed and the use of new technologies and equipment replaced almost all the traditional methods of farming. Besides, in India, there are still some small farmers that use the old traditional methods of agriculture because they lack the resources to use modern methods. Furthermore, this is the only sector that contributed to the growth of not only itself but also of the other sector of the country.

India largely depends on the agriculture sector. Besides, agriculture is not just a mean of livelihood but a way of living life in India. Moreover, the government is continuously making efforts to develop this sector as the whole nation depends on it for food. For thousands of years, we are practicing agriculture but still, it remained underdeveloped for a long time. Moreover, after independence, we use to import food grains from other countries to full-fill our demand. But, after the green revolution, we become self-sufficient and started exporting our surplus to other countries.

II. LITERATURE REVIEW

- 1) R.D. Dhete has worked on "Agricultural fertilizer & pesticides sprayers". In his work he emphasizes on different method of spraying devices Day by day the population of India is increasing and to fulfil the need of food modernization of agricultural sectors are important. Due to chemical fertilizers the fertility of soil is decreasing. Hence farmers are attracted towards organic farming. By mechanization in spraying devices fertilizers and pesticides are distributed equally on the farm and reduce the quantity of waste, which results in prevention of losses and wastage of input applied to farm. It will reduce the cost of production. It will reduce the cost of production. Mechanization gives higher productivity in minimum input. Farmers are using same traditional methods for spraying fertilizers and pesticides. Equipment is also the same for ages. In India there is a large development in industrial sectors compared to agricultural sectors. Conventionally the spraying is done by labours carrying backpack sprayer and fertilizers are sprayed manually. The efforts required are more and beneficial by farmers having small farming land.
- 2) Pavan B. Wayzode, Sagar R. Umale, Rajat R. Nikam, Amol D. Khadke, Hemant carried out their work in "Design Fabrication of Agricultural sprayers, weed with cutter Chemicals are widely used for controlling disease, insects and weeds in the crops. They are able to save a crop from pest attack only when applied in time. The chemicals are costly. Therefore, equipment for uniform and effective application is essential. Dusters and sprayers are generally used for applying chemicals. Dusting, the simpler method of applying chemical, is best suited to portable machinery and it usually requires simple equipment. But it is less efficient than spraying, because of the low retention of the dust. In this work we have proposed an equipment that is wheel and pedal operated sprayer, it is a portable device and no need of any fuel to operate, which is easy to move and sprays the pesticide by moving the wheel and also peddling the equipment. In this equipment using reciprocating pump and there is a accumulator provided for the continuous flows of liquid to create necessary pressure for the spraying action. This wheel operated pesticide spray equipment consumes less time and avoids the pesticide from coming from front of the nozzles which will in contact of the person who sprays pesticides. Weed management is one of the tedious operations in crop production. Because of labour costs, time and fully manual weeding is unfavourable. Hence effort is made to design and develop efficient Farm equipment to perform weeding without using electric power

- 3) According to literature published on flow control of agricultural spraying machine by Massey University New Zealand on different spraying mechanisms are studied. New Zealand relies heavily on its agricultural industry. A large portion of this industry is pastoral farming, where livestock are raised to graze on pasture. This includes beef, sheep and dairy farming. An important aspect of this style of farming is maintaining pasture quality. In order to increase growth, fertilisers are often applied to the pastures. This increase yields in both meat and milk production. However, the increased application of fertiliser is linked with diminishing water quality. While the effects of nitrogen leaching and the best ways to manage fertiliser use are still being investigated, it is clear that control over the application will become more and more important. The Tow and Fert is a range of fertiliser machines designed and built in New Zealand by Metalform Dannevirke. The Tow and Fert range is capable of spraying a wide range of fertilisers including both soluble and non-soluble fertilisers. The Tow and Fert is unique in its ability to spray fertiliser slurries consisting of mixture ratios of up to three-parts fine particle fertiliser to one-part water. This is achieved by the use of a recirculating system. Currently there is next to no control on the flow rate of the machines and the application rate is determined by the speed the operator maintains. The purpose of this thesis is to design and build a flow control system for the Tow and Fert product range and investigate the effect of the changing flow rate on the spray characteristics. The ability to spray such a wide range of fluids with drastically different properties presents many challenges. Many flow meters were considered and a low-cost ultrasonic sensor (TUF2000M) was installed and investigated. After limited success of the ultrasonic sensor, a simple turbine flowmeter was installed. A flow controller was developed and tuned. Based off a PID control loop, the controller was able to maintain flowrate well between 10 L/min and 25 L/min depending on the installed nozzle.
- 4) Sandeep H. Poratkar, Dhanraj R. Rout carried out their work in "Development of Multinozzle Pesticides Sprayer Pump". India is a land of agriculture which comprises of small, marginal, medium and rich farmers. Small scale farmers are very interested in manually lever operated knapsack sprayer because of its versatility, cost and design. But this sprayer has certain limitations like it cannot maintain required pressure; it leads to problem of back pain. However, this equipment can also lead to misapplication of chemicals and ineffective control of target pest which leads to loss of pesticides due to dribbling or drift during application. This phenomenon not only adds to cost of production but also causes environmental pollution and imbalance in natural ecosystem. This paper suggests a model of manually operated multi nozzle pesticides sprayer pump which will perform spraying at maximum rate in minimum time. Constant flow valves can be applied at nozzle to have uniform nozzle pressure.
- 5) Prof. S.V. Deshpande, Damre Mayur & Diwanale Swapnil has worked on "Agricultural Reciprocating Multi Sprayer". In agricultural sector generally farmer uses traditional way that is spray carried on backpack and spraying crop. This becomes time consuming, costly and human fatigue is major concern, these problems can be overcome by using agricultural reciprocating multi sprayer. It facilitates uniform spread of the chemicals, capable of throwing chemicals at the desired level, precision made nozzle tip for adjustable stream and capable of throwing foggy spray depending on requirement. In our project we use slider crank mechanism to convert rotary motion into reciprocating motion to operate the pump, thus the pesticide is spread through the nozzle. This work gives continuously flow of pesticide at required pressure and height. A special arrangement is implemented in this project to adjust the pressure as high or low. We also use a weed cutter in our model for removing unwanted plants. By using agricultural sprayer, spraying time and weeding time, human efforts reduce and result in cost reduction.

III. OBJECTIVES

- 1) Aim of this project is that the farmer need not carry the entire pesticide sprayer pump on his shoulders but just pull/push the mechanism mounted on the trolley to operate the pump and spray the pests. This makes the farmer feel comfortable, relaxed and less tiresome.
 - 2) To reduce human efforts due to the constant pumping action for creating pressure inside the pesticide sprayer and thereby provide a suitable environment for the user reducing the fatigue load acting on the body. As discussed previously, the farmer has to continuously keep on pumping using one of his hands and spray the pests on the crops using the other hand. This at a long run is a tiresome and cumbersome job and the farmer slowly loses interest from it.
 - 3) This project focuses on the problem of health-related issues of the farmer (operator). Majority of them don't use any precautions like face-masks and hand-gloves against the hazardous chemicals and work in direct contact with it. Consequently, this harms the farmer as the spray in the conventional method directly hits the face. Multi-nozzle is used and hence larger area of field can be sprayed at faster rate.
- #### 4. METHODOLOGY

- 4) Multi sprinkle system work on principle of reciprocating pump. This reciprocating pump uses single slider crank mechanism, in which wheel sprocket works as crank. There are two sprockets which is mounted on two different axles in which one sprocket is directly attached to wheel axle. Connecting rod is attached to another sprocket axle through disc. In this power is given to piston of reciprocating pump through rotation of wheel.
- 5) When piston reach at top dead centre, it creates negative or low pressure inside the cylinder due to pressure difference between reservoir and cylinder space, water moves to fill the cylinder chamber space. In this process suction valve open and delivery valve close.
- 6) When piston reaches at bottom dead centre, it creates high pressure inside the cylinder chamber & due to the pressure difference between cylinder & delivery pipe. Water moves through discharge pipe to sprinkle. In this process suction valve closed and delivery valve open. This process repeats again and again to get desire output.
- 7) Motion transmission by chain and sprockets arrangement.
- 8) Slider cranks mechanism.
- 9) Rotary motion converted into reciprocating motion.

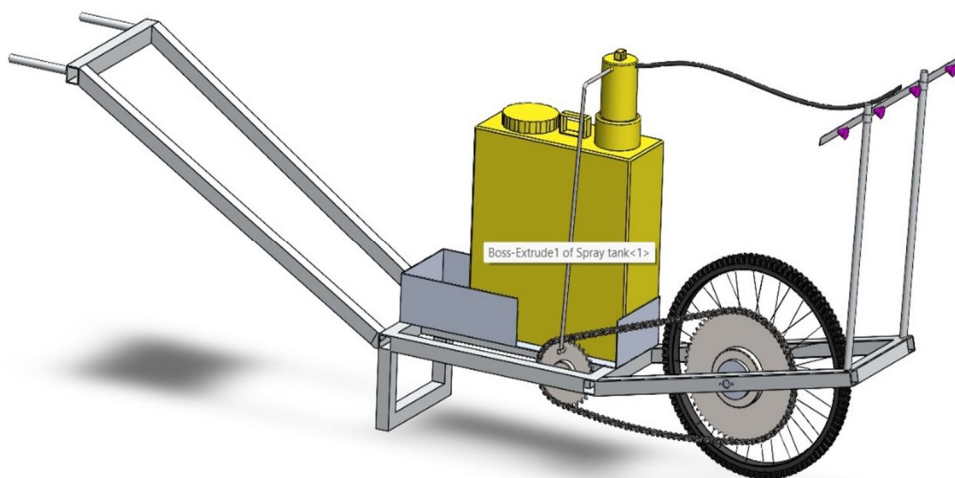

Above figure shows the assembly of the agricultural reciprocating multi sprayer. The operator grabs the handle and pushes the cycle forward as cycle moves forward, the wheel rotate. When the wheel rotates then the gear sprocket mounted on wheel is also rotate at same speed. The chain drive transfers the motion of gear sprocket to pinion sprocket. The pinion sprocket and crank is mounted on either side of same shaft, the rotary motion of shaft is converted into the reciprocating motion with the help of crank and connecting rod mechanism. The connecting rod is also connected with lever and then the lever oscillates at fulcrum. The piston connected at fulcrum produce reciprocating motion in cylinder and the required pressure is achieved. The pesticide from tank sucks in cylinder and piston forced the pesticide to nozzle through the pipe; the numbers of nozzles are connected to spray the pesticide. We can adjust the pressure, which is required for spraying with the help of special arrangement is to change the length of crank by providing slot on crank. By providing some adjustment at joint of connecting rod and lever free rotation of crank or neutral position can be achieved. Using these adjustments pumping is stop and the wheel rotate freely when you need not spray pesticide. Height, position and angle of the nozzle can be adjustable. Water is for most practical purposes incompressible. Consequently, if a close-fitting piston is drawn through a pipe full of water .it will displace water along the pipe. Similarly, raising a piston in a submerged pipe will draw water up behind it to fill the vacuum which would otherwise occur this applies of course only up to a certain limit of the height water can be pulled by a vacuum, as discussed earlier in Section In the first case water is displaced by the piston, but in the second case, the piston serves to create a vacuum and the water is actually displaced by atmospheric pressure pressing on its external surface, as indicated in the figure. So, water can be displaced either by "pushing" or by "pulling", but it can also be "displaced" by a solid object being pushed into water so that the level around it rises when there is nowhere else for the water to go.

IV. APPLICATIONS

- 1) Its major use in agriculture to spray fertilizer.
- 2) In city and urban area, it can use for spraying water on lawn.
- 3) It may be exercise device at morning during utilize in lawn.
- 4) Use from spray chemical Pesticide in plants in farm.
- 5) It is use for spray painting in industry.
- 6) It is use for spray water in garden on the plants.
- 7) It is use for transfer water from one place to its nearer place.
- 8) For the insecticides application to control insect pests on crops and in stores, houses, kitchen, poultry farms, barns, etc.
- 9) For the fungicides and bactericides application to control the plant diseases.
- 10) For the herbicide's application, to kill the weeds.
- 11) For the harmony sprays application to increase the fruit set or to prevent the premature dropping of fruits.
- 12) For the application of plant nutrients as foliar spray.
- 13) For applying the powdery formulation of poisonous chemicals on the crops and for any other purposes.

A. Advantages

- 1) It does not require any kind of non-renewable energy is mechanical, electrical and pressure energy.
- 2) It reduces the fatigue of operator during the operation.
- 3) It increases the efficiency of operator
- 4) It can cover more area of land during spray.
- 5) It can adjust the height of spray by using adjustable
- 6) Its cost is less than electrically and solar operated pump.
- 7) It has is less air pollution. 6.2 Disadvantages
- 8) In irregular area of land, it can difficult to operate.
- 9) In rainy days in muddy environment it is difficult to operate.
- 10) For irregular crops this pump is difficult to work.
- 11) The flow is not uniform, so we have to fit a bottle at both ends.
- 12) The flow is very less & Can't be used for high flow operation.

V. CONCLUSION AND FUTURE SCOPE

A. Conclusion

- 1) The suggested model has removed the problem of back pain, since there is no need to carry the tank on the backbone and solder.
- 2) More no. of nozzle which cover maximum area of spray in minimum time at maximum rate.
- 3) Proper adjustment facility in the model with respect to crop helps to avoid excessive use of pesticides which result into less pollution.
- 4) Imported hollow cone nozzle should be used in the field for the better performance.
- 5) Muscular problem is removed and there is no need to operate lever.
- 6) This alone pump can use for multiple crops.
- 7) After having a trial, we have found that one finds it easy to operate push type machine.
- 8) The pump can deliver the liquid at sufficient pressure where output of the nozzle in 1min is 0.3 and spray width 0.4m from calculation so that it reaches all the foliage and spreads entirely over the spray surface.
- 9) It is little heavy but efficiently working in rough conditions of farm. It is economical therefore affordable for all kind of farmers.
- 10) It requires comparatively less time for spraying so we can get more fields spraying per day. It is cost effective than the existing spraying pumps available in the market as no direct fuel cost or cost for maintenance is needed for this.
- 11) It is upgraded design of manually operated sprayer and weeder which will be helpful for small land farmers.
- 12) It consumes less time and saves money as compared with conventional spraying and weeding.
- 13) This machine does not require any fuel or power so maintenance is less.

B. Future Scope

- 1) The gear ratio we have used can be changed of this product according to the need. More number of teeth means more fluid will be the operation.
- 2) More number of nozzles can be used.
- 3) The product can be sealed using the casing.
- 4) High capacity backpack can be used.
- 5) A new design can be implemented to eliminate the need for pulling the machine manually.
- 6) Stronger but light in weight materials can be used for the frame.

REFERENCES

- [1] R. Joshua, V. Vasu and P. Vincent. (2010) "Solar Sprayer - An Agriculture Implement", "International Journal of Sustainable Agriculture 2 (1): pp. 16-19, ISSN 2079-2107"
- [2] M. A. Miller, B. L. Steward, M. L. Westphalen "Effects of multi-mode four-wheel steering on sprayer machine performance", American Society of Agricultural Engineers ISSN 0001-2351
- [3] R. D. Fox, R. C. Derksen. (2003) "Visual and image system measurement of spray deposits using water-sensitive paper" Applied Engineering in Agriculture Vol. 19(5): pp. 549-552. American Society of Agricultural Engineers ISSN 0883-8542.
- [4] Laukik P. Raut, Smit B. Jaiswal, Nitin Y. Mohite. (2013, Nov.) "Design, development and fabrication of agricultural pesticides sprayer with weeder", International Journal of Applied Research and studies(IJARS), pp. 1-8, ISSN: 2278-9480.
- [5] Application technology: Problems and opportunities with Knapsack sprayer, Including the critical flow valves or Constant Flow Valves. - David McAuliffe and Vanessa P. Gray.
- [6] Journal of arboriculture weed control in landscape plantings¹ by J.F. Ahrens April 1981 vol. 7, no. 4.
- [7] Backpack Sprayer-Modified for small farm Crop Protection-Rutgers Snyder Research & Extension Farm Staff-Edited by John Grande and Jack Rabin.
- [8] To Spray or Not to Spray: Pesticides, Banana Exports, and Food Safety John S. Wilsona Tsunehiro Otsuki*, b a b Development Research Group (DECRG), World Bank, 1818 H Street NW, Washington, D.C. 20433, USA March 2002.
- [9] Farmers understanding of pesticides safety labels and field spraying practices. By Oluyede Clifford Ajayi and Festus K. Akinnifesi Scientific Research and Essay Vol (2), pp.204-210, June 2007 ISSN 1992-2248@2007 Academic Journals
- [10] Wilcoz. M. 1969. A sprayer for application of small amounts of herbicides to flats. Weed Sci. 17:263- 264
- [11] Performance evaluation of bullock drawn sprayers for cotton crop-m. Veerangouda, k. V. Prakash, Jag Jiwan Ram and G. Neelakantayya
- [12] Designing, construction and evaluation of tractor-back sprayer with Variable Rate Technology (VRT) by using aerial maps information Mehrdad Fouj Lali, Parviz Ahmadi Moghadam² 1 MSc in Mechanics of Agricultural Machinery, Urmia University, Iran ² Assistant Professor in Mechanics of Agricultural Machinery, Urmia University, Iran.
- [13] Effect of the Constant Flow Valves on Performance of Pesticide Sprayer by A. R. Tahir, F.H. Khan, A. A. Khan 1560- 8530/2003/05-1-49-52 International Journals of Agriculture and Biology
- [14] Maharashtra Progressive Agriculture – A new Horizon –Confederation of Indian Industry



10.22214/IJRASET



45.98



IMPACT FACTOR:
7.129



IMPACT FACTOR:
7.429



INTERNATIONAL JOURNAL FOR RESEARCH

IN APPLIED SCIENCE & ENGINEERING TECHNOLOGY

Call : 08813907089  (24*7 Support on Whatsapp)