



IJRASET

International Journal For Research in
Applied Science and Engineering Technology



INTERNATIONAL JOURNAL FOR RESEARCH

IN APPLIED SCIENCE & ENGINEERING TECHNOLOGY

Volume: 10 **Issue:** VI **Month of publication:** June 2022

DOI: <https://doi.org/10.22214/ijraset.2022.44389>

www.ijraset.com

Call:  08813907089

E-mail ID: ijraset@gmail.com

Design & Implementation of Advanced Fire Controller- PRAKASH

Palasri Dhar¹, Ananya Kazi², Rohan Kumar Banerjee³

^{1, 2, 3}Department of Electronics & Communication Engineering, Guru Nanak Institute of Technology, Kolkata, West Bengal, India

Abstract: This paper is the implementation of the fire alarm security system using ARDUINO, digital flame sensor and gas sensor. Flame and infrared light sources with wavelengths ranging from 760 nm to 1100 nm can be detected by the flame sensor. The gas detector detects the concentration of flammable gas present around its placed atmosphere. This gadget is a modern household solution from gas leakages as well as incidents of explosion of cylinders or any emergency situation due to unobserved fire. The objective of this project is to contribute towards the safety of human life or saving a human from fire-hazards.

Keywords: Infrared light, modern household solution, fire-hazards, smoke detector, flame sensor, Arduino UNO

I. INTRODUCTION

Fire alarm system is mainly designed to alert people to an emergency so that action can be taken to resist fire and people can save their lives. Generally the use of fire and gas sensor is seen in petrochemical factories, hospitals, public malls etc. These technologies are part of our daily lives, yet they are frequently disregarded until an emergency arises, at which point they may save our lives.

II. OBJECTIVE

- 1) Flame and infrared light sources with wavelengths ranging from 760 nm to 1100 nm can be detected by the flame sensor.
- 2) The MQ-6 gas detector can detect gas concentrations between 200 and 10,000 parts per million.
- 3) The submersible water pump pumps water and provides initial prevention from spreading fire.
- 4) The GSM module sends an alert message if there is high concentration of gas leakage or the flame sensor senses fire.

III. PROPOSED MODEL

The system is made using ARDUINO UNO, it is a technology built for common people as a safety measure to prevent the loss of property and human life. The presence of fire as well as high concentration of flammable gas such as LPG, propane, Iso-butane and LNG is notified to the user through the buzzer sound and sending an SMS to the registered user's numbers using GSM. People usually neglects to take proper precautions in case of a fire emergency and as a result a lot of their possessions are burnt down into ashes.

In this proposed model, we have attached a water pump which will act as a initial precaution against a small fire and give the users ample amount of time to take proper prevention against the disaster or if needed get away to save lives.

Now a days, there are lot of different types of fire alert devices or instruments available in the market. If user wants to purchase devices according to his multiple requirements then he might have to face difficulties during installation or use of the device. To overcome this problem, this proposed model has two or three modules together incorporated in it. As each module installed in the device work simultaneously, this is very much user friendly compare to the other devices found in the current market.

Other than these features, according to our survey, all the fire alarm system currently available in the market does not have automated fire prevention mechanism. The existing fire extinguishable method only consist of sand tanks, carbon-dioxide tanks and hose pipes that can be controlled manually. But our proposed model consist of submersible pump that can be active automatically, when the flame sensor senses fire and the GSM module will notify the user sending a message as well when the installed MQ6 gas sensor senses high concentration of flammable gas, the GSM module sends an alert message to the user.

One of the most appealing features of this innovation is that it is cheap to anyone, with a total cost of less than 1700 INR. There are few smartphones on the market that offer so many features at such a low price.

IV. CIRCUIT DESIGN & SYSTEM OPERATION

- 1) There are 3 GND pins in ARDUINO UNO.
- 2) Digital flame sensor has 3 pins- Digital output, VCC and GND.
- 3) MQ6 gas sensor has 3 pins- Analogue output, VCC and GND.
- 4) Ground of GSM and FLAME SENSOR and gas sensor are connected with one GND pin of ARDUINO board.
- 5) Digital output pin of FLAME SENSOR is connected to pin no. 4 of ARDUINO board.
- 6) VCC is pin of flame sensor and VCC pin of gas sensor is connected to 5 volt pin of ARDUINO board.
- 7) Analogue output pin of gas sensor is connected to A0 pin of ARDUINO board.
- 8) Ground pin of battery and negative connection of submersible pump is connected together with one GND pin & positive pin of battery is connected with Vin pin of ARDUINO board.
- 9) Positive connection of submersible pump is connected with the A5 pin of ARDUINO board.
- 10) The positive pins of BUZZER & LED are connected to pin no.13 of ARDUINO board.
- 11) The negative pins of BUZZER & LED is connected one GND pin of ARDUINO board.
- 12) GSM module TX pin- pin no. 2 ARDUINO board.
- 13) GSM module RX pin- pin no. 3 ARDUINO board.
- 14) After connecting all of this we uploaded ARDUINO code to our ARDUINO board and tested it performance.

The detailed circuit with connection is shown in the figure.

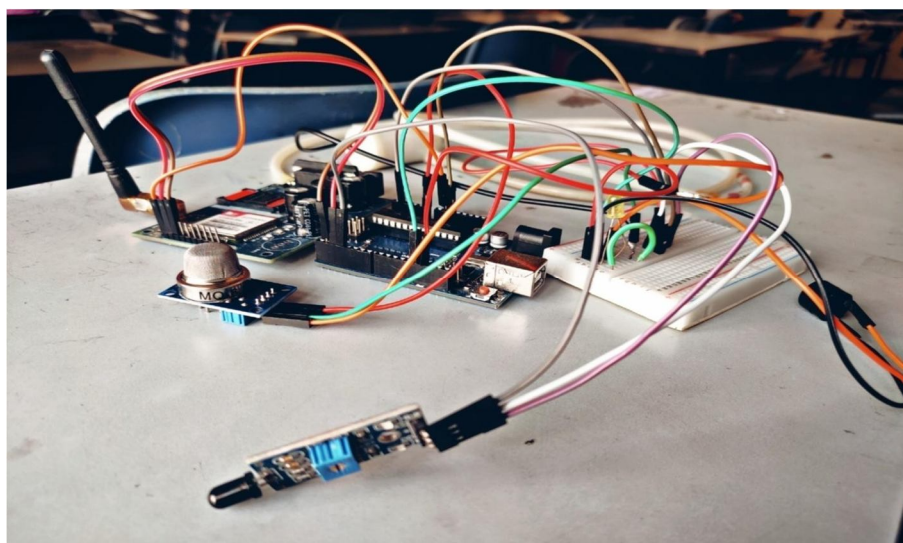
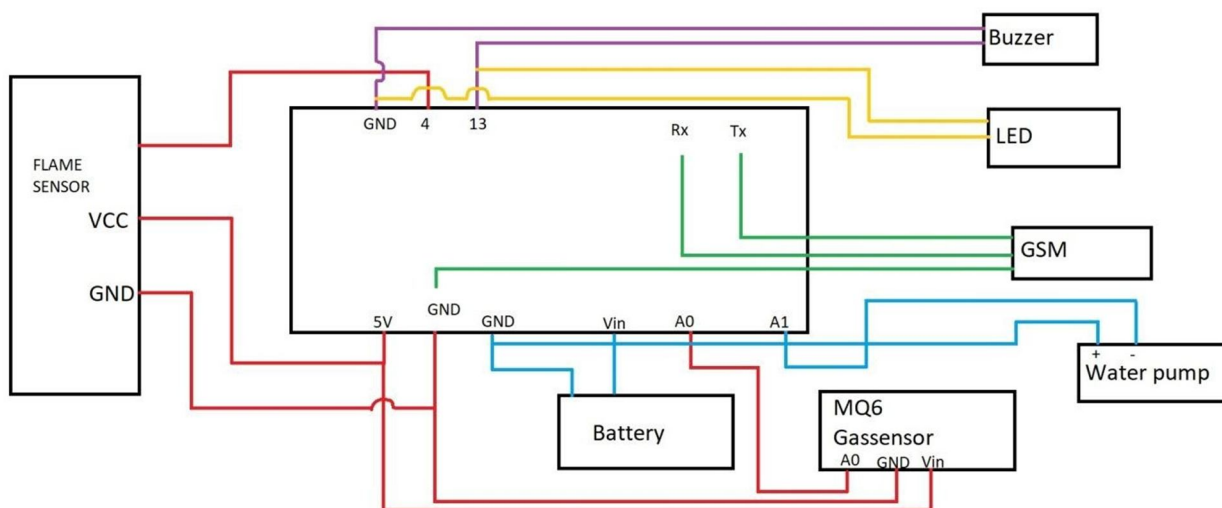

V. CONCLUSION

Although we have successfully completed with this ARDUINO project but there is always an effort from our side in making this project much more improved of what exists now. We plan on making this device portable by adding GPS module with the existing one. So that a continuous monitoring of location can be delivered to the user and the proper authorities and real time precautions can be taken.

REFERENCES

- [1] www.fire.org.nz/...Fire...Alarms/
- [2] Huide Liu ; Lili Gao ; Suwei Li ; Tao Wu “ About automatic fire alarm systems research”, The 2nd IEEE International Conference on Information Management and Engineering (ICIME), 16-18 April 2010, pp. 419 – 421.
- [3] Lei Zhang, and Gaofeng Wang, “Design and Implementation of Automatic Fire Alarm System based on Wireless Sensor Networks”,
- [4] Proceedings of the 2009 International Symposium on Information Processing (ISIP'09) Huangshan, P. R. China, August 21-23, 2009, pp. 410-413
- [5] Omar Asif, Md. Belayat Hossain, Mamun Hasan, Mir Toufikur Rahman, Muhammad E. H. Chowdhury, “Fire-Detectors Review and Design of an Automated, Quick Responsive FireAlarm System Based on SMS”, Scientific Research Publishing Inc, 28th August 2014.
- [6] www.systemsensor.com.
- [7] www.pertronic.co.nz/convention_systems/
- [8] Alonso, F. (1996). La Seguridad en Calderas, INSHT, Madrid, España. Dukelow, S.G. (1991). The Control of Boilers, ISA, Research Triangle Park, USA. Feliú, V., Rivas, R., Castillo, F., Sotomayor J. (2005).
- [9] Control Fraccional de Calderas Industriales Pirotubulares, Automatica and Instrumentation, N°365, 90-95. Gilman, G.F. (2005).
- [10] Boiler Control Systems Engineering, ISA – Instrumentation, Systems and Automation Society. Hogg, B.W., El-Rabaie, N.M. (1990). Generalized Predictive Control of Steam Pressure in a Drum Boiler, IEEE Trans. Energy Conversion, Vol. 5, N° 3, 485-492. Lindsley, D.M. (2000).
- [11] Power-plant Control and Instrumentation. The Control of Boilers an HRSG Systems, IEEE Control Engineering Series, Londres. Lindsley, D.M. (1991).
- [12] Boiler Control System, Mc-Graw Hill, London. Ljung, L. (1999). System Identification – Theory for
- [13] the User, Second Edition. Prentice Hall, Englewood Cliffs, NJ. Rivas, R., Aref, R., Perán, J.R., Sánchez, C. (2000).
- [14] Industrial Boilers. Integral Automatic Control System, Automatica and Instrumentation, No. 308, 79-80.



10.22214/IJRASET



45.98



IMPACT FACTOR:
7.129



IMPACT FACTOR:
7.429



INTERNATIONAL JOURNAL FOR RESEARCH

IN APPLIED SCIENCE & ENGINEERING TECHNOLOGY

Call : 08813907089  (24*7 Support on Whatsapp)