



IJRASET

International Journal For Research in
Applied Science and Engineering Technology



INTERNATIONAL JOURNAL FOR RESEARCH

IN APPLIED SCIENCE & ENGINEERING TECHNOLOGY

Volume: 10 **Issue:** VI **Month of publication:** June 2022

DOI: <https://doi.org/10.22214/ijraset.2022.43495>

www.ijraset.com

Call:  08813907089

E-mail ID: ijraset@gmail.com

Effect of Semi-Rigid Joints on Design of Steel Structure

Ms. Chinmyi Burle¹, Prof. S.K. Nalawade², Dr. Navnath V. Khadake³

¹Post Graduate Student, Department of Civil Engineering, JSPM's ICOER, Pune, India

²Associate Professor, ³Head of Department, Department of Civil Engineering, JSPM's ICOER, Pune, India

Abstract: Limit state design method has presented a new era of safe and economic construction for steel structures. New standard IS 800:2007 for design of steel structures has provided an opportunity for modern design philosophy, design specifications and provisions as per Limit State Method of design in our country. In design of steel structures, steel connections are important elements for controlling behaviour of structure. It is essential that to understand behaviour of steel frame, connectors are required to develop full or a little higher strength compared to members being joined in order to achieve a safe and an economical design. A connection rotates through angle θ Or caused by applied moment M . This is angle between beam and column from their original position. Several moment-rotation relationships have been derived from experimental studies for modelling semi-rigid connections of steel frames. These relationships vary from linear model to exponential models and are non-linear in nature. Connections possess semi rigid end conditions in actual behaviour. In the present dissertation, the effect of semi rigid joints on design of steel structures is studied. The behaviour of semi rigid connections and its modelling is discussed. The analysis of the frames is done using ANSYS 2016 and the comparative results of rigid, semi rigid and pinned end conditions has been presented in graphical form. From the results of analysis the design of various semi rigid connections is carried out. Further buckling analysis of stepped columns has been carried out in order to obtain effective length parameters for semi-rigid connections. The design examples has been solved using AISC and IS 800-2007. The comparison is done for fixed, semi rigid and pinned end condition.

Keyword: semi-rigid joint, frame analysis, rotational stiffness, buckling length, genetic algorithm.

I. INTRODUCTION

Since steel has been employed in the building of structures, it has enabled the creation of some of history's and today's largest structures. With 10 times the strength of concrete, steel is by far the most usable material for constructing structures. Steel is the perfect material for contemporary construction. For tall buildings, big span buildings, and bridges, steel structures are often more cost-effective than concrete structures due to their high strength-to-weight ratio. Steel buildings may be created rapidly, allowing them to be used sooner and contributing to total economics. Steel constructions are ductile and durable, allowing them to endure intense loads such as earthquakes. Steel buildings are readily repairable and adaptable for carrying greater weights. Steel is also an environmentally beneficial material, and steel constructions can be readily removed and recycled. Thus, the lifespan cost of steel structures, including construction, maintenance, repair, and dismantlement, may be cheaper than that of concrete ones. Because steel is manufactured in a facility under stricter quality control, steel constructions are more reliable and secure. Steel constructions should be constructed and protected to withstand corrosion and fire in order to maximize their use. They should be designed and specified to facilitate fabrication and assembly. Good quality control is required to guarantee that the different structural parts fit together properly. Temperature impacts should be addressed during design. To avoid the formation of fractures under fatigue and seismic stresses, the connections and, in particular, the welds must be carefully planned and specified. Special steels and anti-corrosion and anti-fire measures are available, and the designer should be conversant with these alternatives. A steel structure, like any other, consists of a collection of parts that contribute to resisting the entire weight and securely transferring it to the ground. This includes elements subjected to axial forces (compression and tension), bending, shear, torsion, etc., or a combination thereof. The components are held together by rivets, pins, or welds. The connections are classed as stiff, semi-rigid, or flexible depending on the fixity of these joints.

A. Properties of Structural Steel

The properties of structural steel, as per clause 2.2.4 of IS 800:2007, for use in design, may be taken as given in clauses 2.2.4.1 and 2.2.4.2 of the code.

- 1) *Physical Properties:* Physical properties of structural steel, as detailed by cl.2.2.4.1 of IS 800:2007, irrespective of its grade may be taken as: a) Unit mass of steel, $p = 7850 \text{ kg/m}^3$ b) Modulus of elasticity, $E = 2.0 \times 10^5 \text{ N/mm}^2 \text{ (MPa)}$ c) Poisson ratio, $\nu = 0.3$ d) Modulus of rigidity, $G = 0.769 \times 10^5 \text{ N/mm}^2 \text{ (MPa)}$ e) Coefficient of thermal expansion $\alpha = 12 \times 10^{-6}/^\circ\text{C}$
- 2) *Mechanical Properties:* The principal mechanical properties of the structural steel important in design, as detailed by the code IS 800:2007 in cl. 2.2.4.2, are the yield stress, f_y ; the tensile or ultimate stress, f_u ; the maximum percent elongation on a standard gauge length and notch toughness. Except for notch toughness, the other properties are determined by conducting tensile tests on samples cut from the plates, sections, etc., in accordance with IS 1608. Commonly used properties for the common steel products of different specifications are summarized in Table 1 of IS 800:2007. Highlights of the table are reproduced for ready reference as Table 1.

Table 1. Tensile Properties of Structural Steel Products

IS Code	Grade	Yield stress (Map) min (for d or t)			Ultimate tensile stress (MPa) min	Elongation Percent min
		<20	20 - 40	>40		
	E 165 (Fe 290)	165	165	165	290	23
	E250(Fe410W)A	250	240	230	410	23
	E250(Fe 410 W)B	250	240	230	410	23
	E250(Fe 410 W)C	250	240	230	410	23
IS 2062	E 300 (Fe 440)	300	290	280	440	22
	E 350 (Fe 490)	350	330	320	490	22
	E 410 (Fe 540)	410	390	380	540	20
	E 450 (Fe 570) D	450	430	420	570	20
	E 450 (Fe 590) E	450	430	420	590	20

B. Advantages of Steel Structures

1) Design

One of the most evident advantages of using a steel structure in construction is the ability of steel to span greater distances with steel ceiling joists. This allows engineers to expand their options, allowing them to create new/large space using steel products that just weren't available with other materials. A steel structure is highly recommended for large span and heavy structures which benefits all types of Industrial buildings. Lower floor to floor heights can easily be constructed using staggered truss, girder slab, and castellated beam construction. Extremely long open spans are possible using steel that would not be possible to implement in concrete or with wood support. The most economical and general shape for a prefabricated steel building is a basic rectangle. However, steel is also used to create more complex designs. Steel's greatest design asset maybe its ability to span long distances without interrupting the related interior columns. That is why aircraft hangars builders use steel framing. A clear span interior space provides more floor-plan flexibility. It also allows greater freedom for later renovations and changes. It is a simple-to-design cantilever made with steel.

2) Strength and Durability

Structural steel components are stronger and lighter than the components made of weight-bearing concrete or wood. Weight-bearing steel fabrication is 30%-50% lighter than its wooden equivalent. This makes construction of steel structure stronger and more durable than traditional wooden structure.

Besides offering durability, a steel structure can withstand extreme forces or harsh weather conditions, such as earthquakes, strong winds, hurricanes and heavy snow to a larger extent. They are also rust-proof and, unlike wooden structures, they are not affected by termites, mildew, bugs, mold, and fungal contamination. And also, they are more fire-resistant compared to wooden/RCC structures.

3) Light in Weight

This may be surprising to know that if you weigh 2x4 square feet piece of wood and 2x4 square feet piece of steel, the steel would weigh more due to its density. However, when steel is used in framing, the design of beam will cause it to be lighter than a structurally sound wooden/concrete beam design.

4) *Easy Installation and Speed in Construction*

Steel parts in a steel structures are pre-manufactured to a specific design inside the manufacturing plant/fabrication shop and are shipped out in ready-to-be erected condition. Hence it speeds up construction time significantly. So, it is possible to complete large-scale projects in a shorter period than usual.

According to 'Francis D. K. Chin' (Author of Building Construction Illustrated), conventional steel structures are constructed out of hot-rolled beams and columns, open-web joists, and metal decking. Since structural steel is difficult to make on site, it is generally cut, shaped, and drilled in a fabrication shop as per the design specifications; this can result in comparatively fast and precise construction.

Due to easy-to-make parts of a steel structure, it is hassle-free to install and assemble them on site, and also there is no need of measuring and cutting of parts on site.

5) *Versatile*

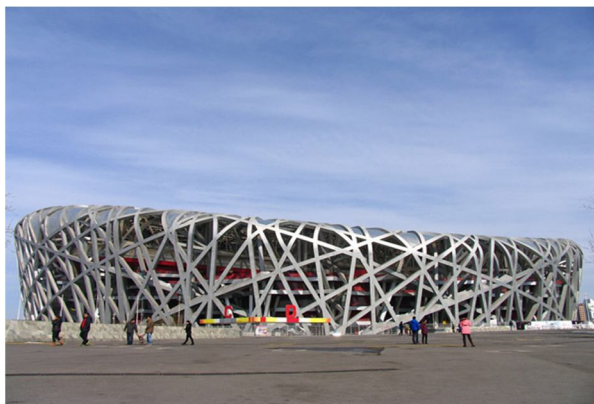

Fig.1 Versatile

Steel is incredibly versatile as it can be molded into almost any shape, which makes it an attractive option for both residential and commercial buildings. Architects may let their artistic imaginations run wild, while still having the ability to design and construct a building that is both strong and safe. Similarly, for the adaptability to the versatile design of large, clear span buildings such as airport, terminal buildings, auditorium, halls, agricultural buildings, warehouses, and indoor areas, there are hardly any alternatives to steel structures.

II. LITERATURE REVIEW

- 1) Bayan A, et.al (2011) "Cold formed steel joints and structures" Conducted study on this document contains three works. First, an introduction to cold-formed steel constructions is reviewed. Second, it provides an overview of the main design concerns for cold-formed steel structures. It concludes with a summary of joint and structural studies for cold-formed steel. In recent years, stronger materials and a broader variety of structural applications have led to a significant advancement in cold-formed steel in comparison to the more prevalent, heavier hot-rolled steel structural elements. Understanding the performance of cold-formed steel becomes a significant area of research.
- 2) Lanhui Guo, et.al (2015) "Structural Performance of semi-rigid composite frame under column loss" Conducted study on the behaviour of the semi-rigid connection under single column removal scenario, a pseudo-static test of a composite frame with flush-endplate connections under the loss of middle column was carried out. Also, a FE model using both 3-D elements and 2-D elements was developed and analyzed. The accuracy of FE analysis results are validated by comparing with the experimental results. The analytical results showed that the progressive collapse resistance is sensitive to the properties of bolts. Increasing the fracture strain of bolts, the progressive collapse resistance of composite frame improves obviously. Increasing the diameter of bolts shank could also increase the loading-capacity and ductility of the connection. At last, some measures are suggested to improve the behavior of connection in resisting progressive collapse. Among them, a new technique called angle-steel reinforcement method is proved to be a good way to improve the progressive resistance of semi-rigid composite frame. The catenary action associated to significant second order effects plays an important role in resisting the additional loads when structural column is destroyed under unexpected loads. The capacity and ductility of beam-to-column connection is one of the key factors in the formation and performance of catenary action.

- 3) Concepción Díaz, et.al (2011) “Review on the modelling of joint behaviour in steel frames” Conducted study on the papers of reviews three areas of steel joint research: (1) analysis methods of semi-rigid joints; (2) prediction methods for the mechanical behaviour of joints; (3) mathematical representations of the moment–rotation curve. Steel portal frames were traditionally designed assuming that beam-to-column joints are ideally pinned or fully rigid. This simplifies the analysis and structural design processes, but at the expense of not obtaining a detailed understanding of the behaviour of the joints, which in reality, have finite stiffness and are therefore semi-rigid. The last century saw the evolution of analysis methods of semi-rigid joints, from the slope-deflection equation and moment distribution methods, to matrix stiffness methods and, at present, to iterative methods coupling the global and joint structural analyses. Studies agree that in frame analysis, joint rotational behaviour should be considered. This is usually done by using the moment–rotation curve. Models such as analytical, empirical, experimental, informational, mechanical and numerical can be used to determine joint mechanical behaviour.
- 4) Alfonsas Daniūnas, et.al (2010) “Influence of the semi-rigid bolted steel joints on the frame behaviour” Conducted study on the research work describes the analysis of steel semi rigid joints that are subjected to bending and tension or compression. The main attention is focussed on the beam-to-beam and plate bolted joints. Usually influence of axial force is neglected. In fact, the level of tension or compression of axial force can be significant and has some impact on joint behaviour and on its stiffness and strength characteristics. Nowadays the most powerful method for the estimation of joints characteristics is the component method. The adaptation of the component method for the determination of joints characteristics under bending and axial forces is shown in the paper.
- 5) M.A. Hadianfard, et.al (2003) “Effects of semi-rigid behavior of connections in the reliability of steel frames” Conducted study on The paper considers the effects of semi-rigid behavior of the connections in the finite element analysis and in the reliability analysis of steel frames. Assuming that the loads and the resistance of members are random variables, then the Monte Carlo simulation technique is used for the best estimation of the probability of failure of the frame system. Some examples are presented, which illustrate the importance of the effect of the semi-rigid behavior of the connections in the calculation of the overall reliability of the total system of the steel frames. The actual behavior of beam to column connections in steel frames is seldom fully rigid or fully pinned. The true behavior of the connections is usually semi-rigid. Neglecting the real behavior of the connection in the analysis may lead to unrealistic predictions of the response and reliability of steel frames.
- 6) M. Gholipour Feiz, et.al (2015) “Effect of semi-rigid connections in improvement of seismic performance of steel moment-resisting frames” Conducted study on this study showed that in all frames, it could be found a state of semi-rigidity and connections configuration which behaved better than rigid frame, with consideration of the base shear and story drifts criterion. Finally, some criteria were suggested to locate the best place of the semi-rigid connections for improvement of the seismic performance of steel moment-resisting frames .Seismic performances of dual steel moment-resisting frames with mixed use of rigid and semi-rigid connections were investigated to control of the base shear, story drifts and the ductility demand of the elements. To this end, nonlinear seismic responses of three groups of frames with three, eight and fifteen story were evaluated. These frames with rigid, semi-rigid and combined configuration of rigid and semi-rigid connections were analyzed under five earthquake records and their responses were compared in ultimate limit state of rigid frame.

III. MODELLING AND ANALYSIS

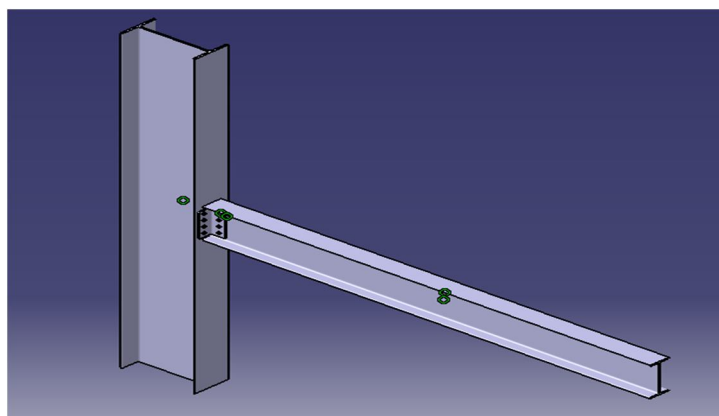

Fig 2: Single web angle

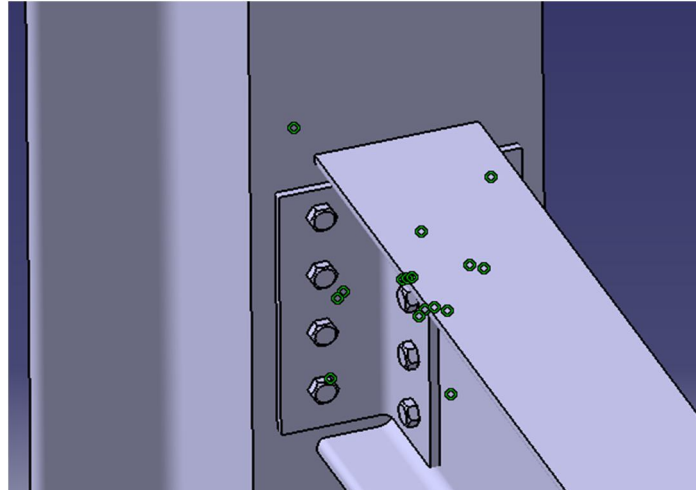

Fig 3: Double web angle

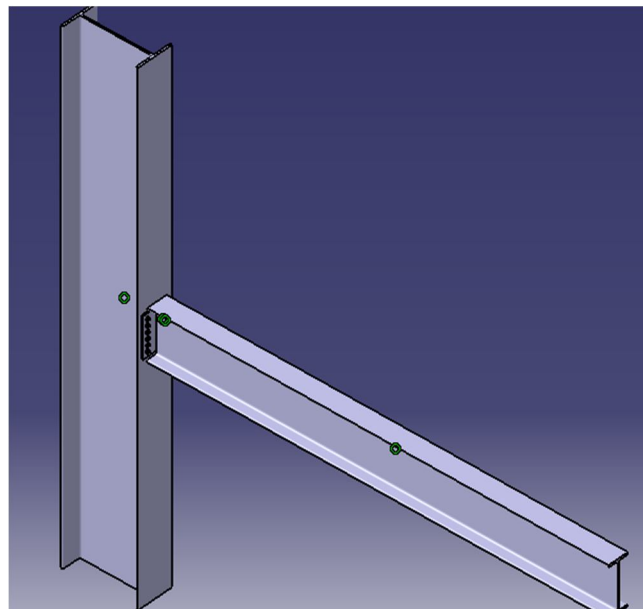

Fig 4 : Header Plate

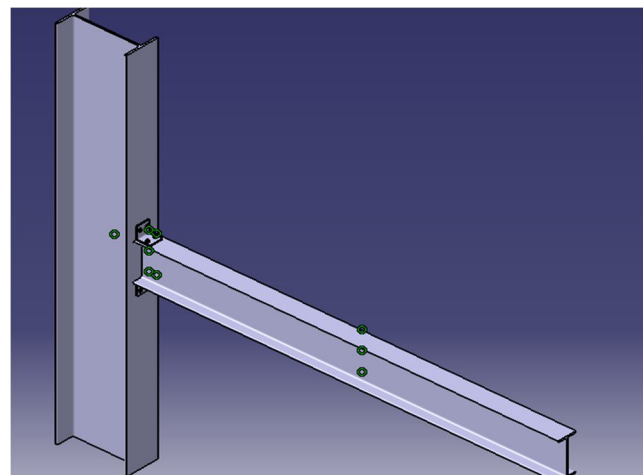

Fig 5 : Top and seat cleats model

IV. RESULT AND DISCUSSION

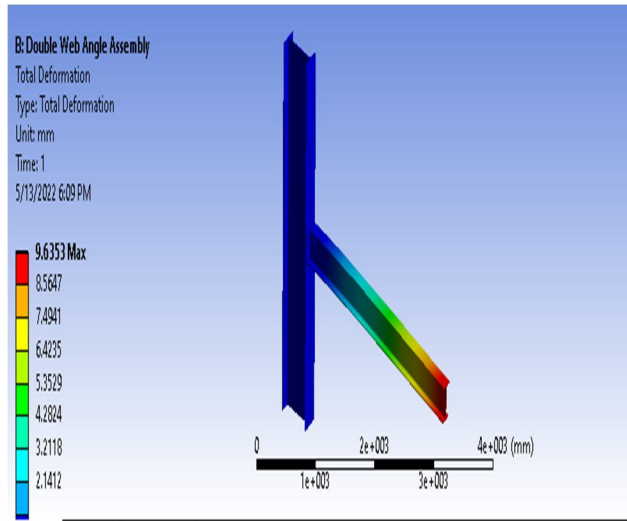

Fig 6 : Total Deformation

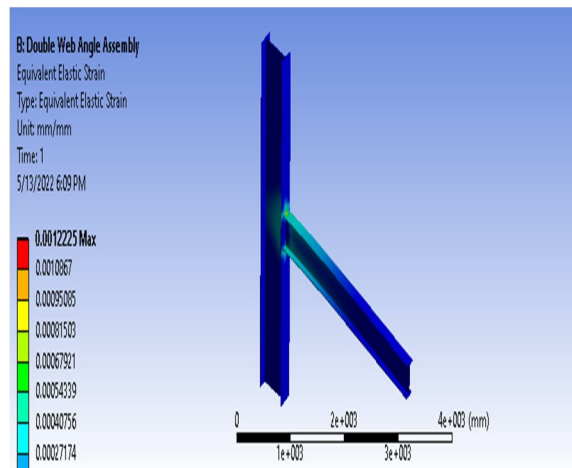

Fig: Equivalent Elastic Strain

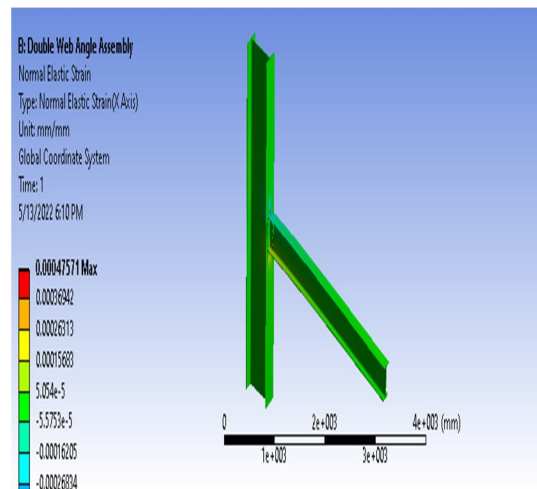

Fig: Normal Elastic Strain

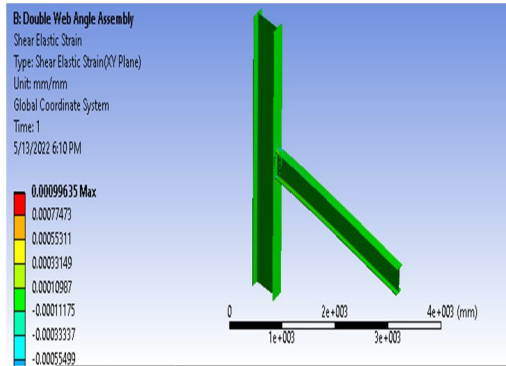

Fig: Shear Elastic Strain

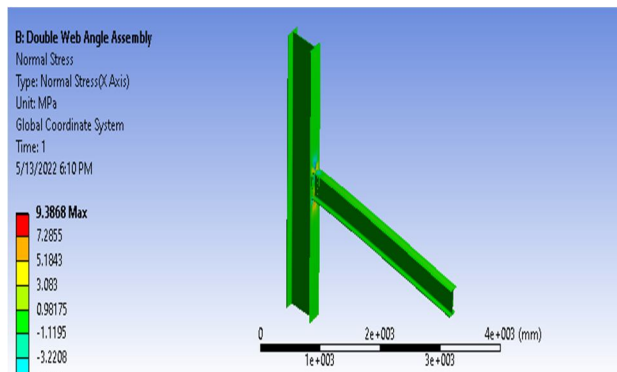

Fig: Normal Stress

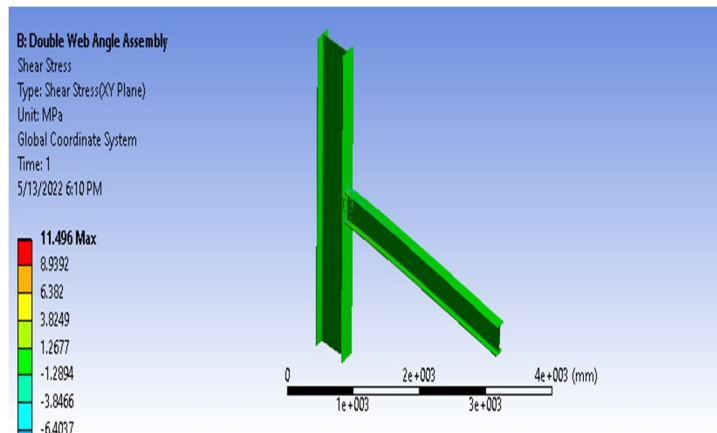

Fig: Shear Stress

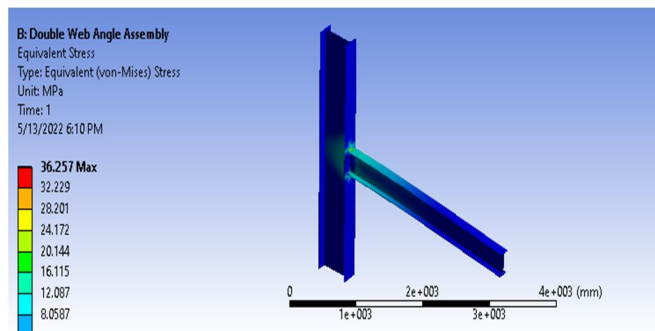
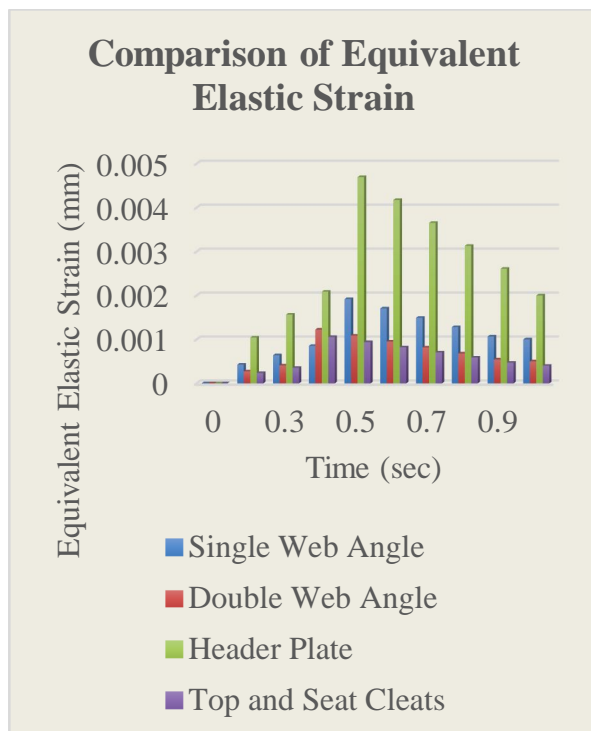
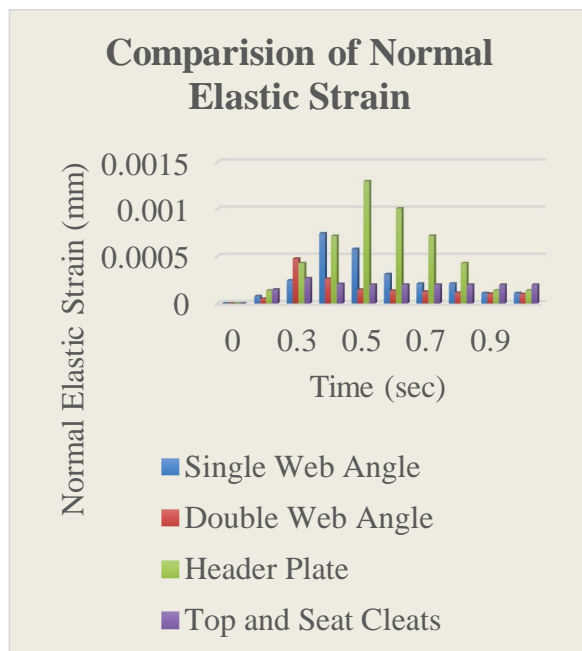

Fig: Equivalent Stress



Graph 1: Equivalent Elastic Strain

In the equivalent elastic strain graph, maximum equivalent elastic strain seen in header plate model and minimum equivalent elastic strain seen in top and seat cleats models.



Graph 2 : Normal Elastic Strain

In the normal elastic strain graph, maximum normal elastic strain seen in header plate model and minimum normal elastic strain seen in top and seat cleats models.

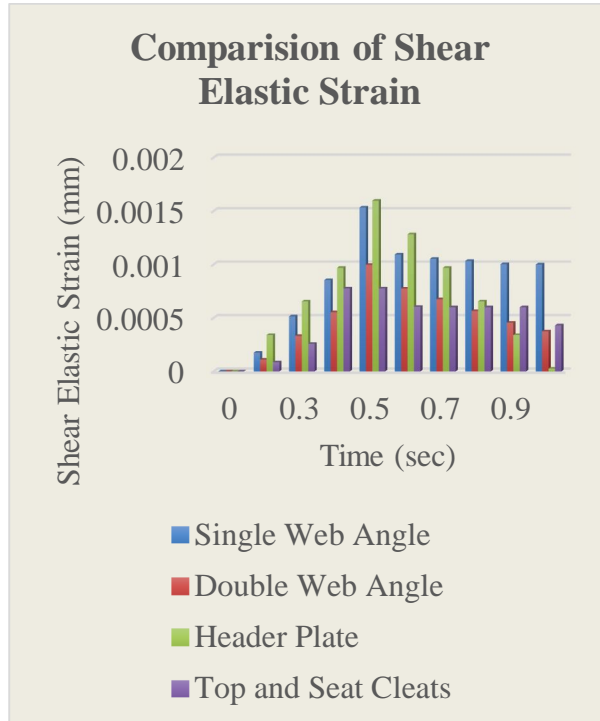

Graph 3: Shear Elastic Strain

In the shear elastic strain graph, maximum shear elastic strain seen in header plate model and minimum shear elastic strain seen in top and seat cleats models.

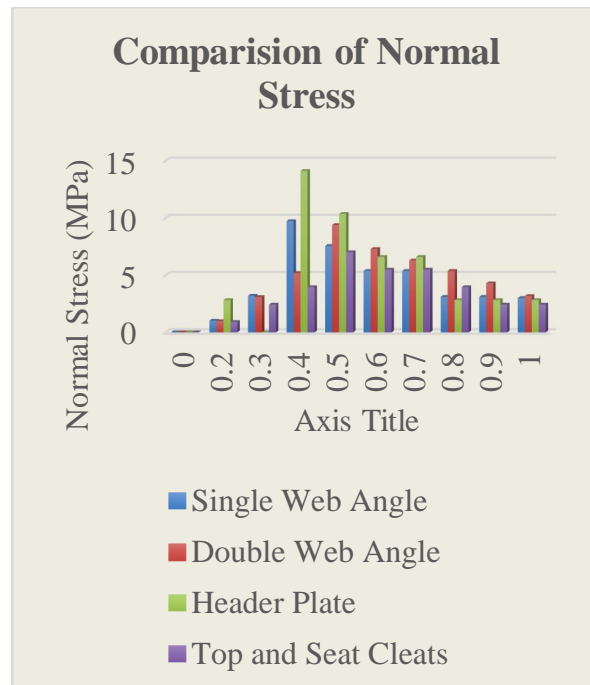

Graph 4: Normal Stress

In the normal stress graph, maximum normal stress seen in header plate model and minimum normal stress seen in top and seat cleats models.

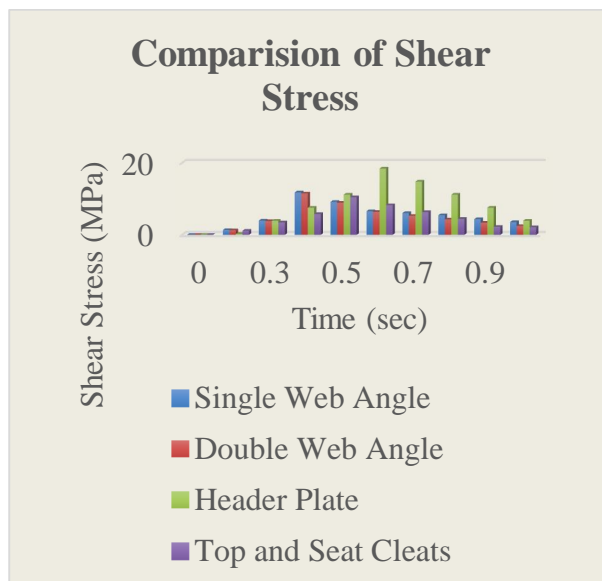

Graph 5: Shear Stress

In the shear stress graph, maximum shear stress seen in header plate model and minimum shear stress seen in top and seat cleats models.

V. CONCLUSION

A steel column is a vertical structural element used in building to provide critical support. They may bear compression loads or transmit loads from beams, ceilings, floor slabs, or roof slabs to floors or foundations. Bending moments along cross-section axes may also exist in steel columns. It is desirable to avoid brittle shear failure of beam-column junctions in their design and details. Unsafe joint design and details will cause damage to the whole structure, even if the other structural parts meet the design criteria. Reinforced concrete beam-column joints are a popular external moment resistant frame in buildings. Understanding the complicated behavior of this joint approach under repeated load is critical due to their fundamental materials' restricted strengths, which might result in limited force carrying capability.

- 1) To get the knowledge about the settle structure also to study detailed basic behavior connections like rigid connections, semi rigid connection, pin connections and effect of semi rigid on analysis and design of frame identified an analysis the stability of stepped Coolum using Ansys workbench.
- 2) In the total deformation graph, maximum deformation seen in header plate model and minimum deformation seen in top and seat cleats models.
- 3) In the equivalent elastic strain graph, maximum equivalent elastic strain seen in header plate model and minimum equivalent elastic strain seen in top and seat cleats models.
- 4) In the normal elastic strain graph, maximum normal elastic strain seen in header plate model and minimum normal elastic strain seen in top and seat cleats models.
- 5) In the shear elastic strain graph, maximum shear elastic strain seen in header plate model and minimum shear elastic strain seen in top and seat cleats models.

REFERENCES

- [1] Bayan, A., Sariffuddin, S., Hanim, O., Bayan A, Sariffuddin S, & Hanim O. (2011). Cold formed steel joints and structures -A review. International Journal of Civil and Structural Engineering, 2(2), 621–634.
- [2] Gholipour Feizi, M., Mojtahedi, A., & Nourani, V. (2015). Effect of semi-rigid connections in improvement of seismic performance of steel moment-resisting frames. Steel and Composite Structures, 19(2), 467–484. <https://doi.org/10.12989/scs.2015.19.2.467>
- [3] Hadianfard, M. A., & Razani, R. (2003). Effects of semi-rigid behavior of connections in the reliability of steel frames. Structural Safety, 25(2), 123–138. [https://doi.org/10.1016/S0167-4730\(02\)00046-2](https://doi.org/10.1016/S0167-4730(02)00046-2)
- [4] Daniunas, A., & Urbonas, K. (2010). Influence of the semi-rigid bolted steel joints on the frame behaviour. Journal of Civil Engineering and Management, 16(2), 237–241. <https://doi.org/10.3846/jcem.2010.27>
- [5] Daz, C., Mart, P., Victoria, M., & Querin, O. M. (2011). Review on the modelling of joint behaviour in steel frames. Journal of Constructional Steel Research, 67(5), 741–758. <https://doi.org/10.1016/j.jcsr.2010.12.014>
- [6] Guo, L., Gao, S., & Fu, F. (2015). Structural performance of semi-rigid composite frame under column loss. Engineering Structures, 95, 112–126. <https://doi.org/10.1016/j.engstruct.2015.03.049>



10.22214/IJRASET



45.98



IMPACT FACTOR:
7.129



IMPACT FACTOR:
7.429



INTERNATIONAL JOURNAL FOR RESEARCH

IN APPLIED SCIENCE & ENGINEERING TECHNOLOGY

Call : 08813907089  (24*7 Support on Whatsapp)