



IJRASET

International Journal For Research in
Applied Science and Engineering Technology



INTERNATIONAL JOURNAL FOR RESEARCH

IN APPLIED SCIENCE & ENGINEERING TECHNOLOGY

Volume: 11 Issue: V Month of publication: May 2023

DOI: <https://doi.org/10.22214/ijraset.2023.51397>

www.ijraset.com

Call:  08813907089

E-mail ID: ijraset@gmail.com

Enhance Power Quality through Series Compensation in Power System

Sachin A. Jalit¹, A. K. Duchakke², S.V.Bhonde³

^{1, 2, 3}PRPCEM, Amravati, India

Abstract: *The power quality requirement is one of the most important issues especially with the introduction of sophisticated device whose performance is very sensitive to the quality of power supply. Power quality problem is an occurrence manifested as a non standard voltage, current or frequency that results in failure of end user equipment. One of the major problem deal with sag and harmonics .To solve this problem series compensation is used to improve power quality of an isolated power system is considered. The role of compensator not only mitigates voltage sag but also reduces harmonics due to presence of nonlinear load in the network. In this paper series compensation is proposed and principle of harmonics mitigation is explain and the compensation strategies and control philosophy used in series compensation is explain. The isolated power system model is simulated in matlab Simu link software and simulation result shows the reduce harmonics and thus improve power quality of the isolated power system*

Index Terms -Harmonics, Power quality problem, injection transformer, ESS, VSI,

I. INTRODUCTION

Power quality problems encompass a wide range of disturbances such as voltage sags/swells, flickers, harmonics distortion, impulse transient, and interruptions. Sag is a decrease of R.M.S voltage to a value between 0.1to 0.9 p.u and lasting for a duration 0.5cycle to 1minute .voltage sag as a voltage dip. Voltage sag are mainly due to system fault. Harmonics are sinusoidal voltage or current having frequencies that are integer multiple of the frequency at which supply system is designed to operate (termed the fundamental frequency for usually 50or 60 Hz. Isolated power systems are commonly found in rural and remote areas of the world. Isolated power systems are characterized by limiting generating capacity. The sensitive loads which are present in the isolated power systems are much more affected by the power quality problems. Power Electronics and Advanced Control technologies have made it possible to mitigate power quality problems and maintain the operation of sensitive loads. Among power system disturbances, voltage sags, swells and harmonics are some of the severe problems to the sensitive loads, because

- 1) The occurrence of voltage sag in the system can cause devices/process down time, effect on product quality failure/malfunction of equipments etc.
- 2) The occurrence of harmonics in the system can cause excessive losses and heating in motors, capacitors and transformers connected to the system.

To avoid those undesirable affects the proposed method mitigates the problems caused by voltage sag and harmonics. In the proposed system Voltage sag occurs due to the three phase fault in the transmission line and harmonics occurs due to the connection of controlled six pulse converter to the main drive load(nonlinear load). All these factors affect the sensitive load which is connected in parallel to the main drive load. So the proposed system protects the sensitive load by mitigating the voltage sags and harmonics using series compensation technique.

A. Main Sources, Causes Of Electrical Power Quality Problem-

Power quality problem is an occur as a non-standard voltage, current and frequency. The power quality has serious economic implications for customers, utilities and electrical equipment manufacturers. However, in practice, power systems, especially the isolated systems are some of the source of distortion.

Causes of dips, sags and surges:

- 1) Rural location remote from power source
- 2) Unbalanced load on a three phase system
- 3) Switching of heavy loads
- 4) Long distance from a distribution transformer with interposed loads
- 5) Unreliable grid systems

6) Equipment's not suitable for local supply

B. Major Problems That Arise From Harmonic Distortion Are

- 1) Extra losses and heating in rotating machines and capacitors
- 2) Over voltages due to resonance
- 3) Interference with ripple control systems used in Demand Side Management (DSM)
- 4) Telephone interference caused by noise on telephone lines

II. SYSTEM MODEL

Among the power quality problems (sags, swells, harmonics...), voltage sags are the most severe disturbances. In order to overcome these problems the concept of Series compensator which is used in power distribution network, the function of s.c. will be to inject the missing voltage in order to regulate the load voltage from any disturbance due to immediate distort of source voltage .

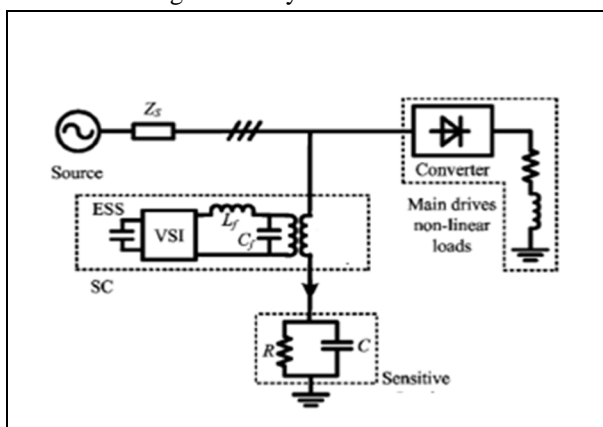

Fig-1 Typical isolated power system model

The DC side of SC is connected to an energy source or an energy storage device, while its ac side is connected to the three-phase inter facing injection transformer. Typical isolated power system model as shown in fig [1] is used to explain the proposed harmonics compensation method of sc. The upstream generator are aggregated and represented as an ideal voltage source. Z_s represented equivalent source impedance. The main drive load connected to source through power convertor small capacity of sensitive load is assumed to be supplied through point of common coupling and molded by resistor in parallel with capacitor. This is connected upstream from sensitive load through a injection transformer. it is series connected with sensitive load.

Basic Configuration of SC:

The general configuration of the sc consists of:

- 1) An Injection/ Booster transformer/Isolation transformer
- 2) Harmonic filter/Passive filter
- 3) Storage Devices/ESS
- 4) Voltage Source Converter (VSC)/VSI
- 5) DC charging circuit
- 6) Control and Protection system

A. Injection/ Booster Transformer/Isolation Transformer-

The Injection / Booster transformer is a specially designed transformer that attempts to limit the coupling of noise and transient energy from the primary side to the secondary side. In a three-phase system, either three single-phase transformer units or one three phase transformer unit can be used for voltage injection purpose. The injection transformer comprises of two side voltages namely the high voltage side and low voltage side. The basic function of the injection transformer is to increase the voltage supplied by the filtered VSI output to the desired level while isolating the sc circuit from the distribution network. The transformer winding ratio is pre-determined according to the voltage required in the secondary side of the transformer (generally this is kept equal to the supply voltage to allow the sc to compensate for full voltage sag).

B. Harmonic Filter/Passive Filter

The passive filters can be placed on the high voltage side or the converter side of the injection transformers. Basically filter unit consists of inductor (L) and capacitor (C). In DVR, filters are used to convert the inverted PWM waveform into a sinusoidal waveform. This can be achieved by eliminating the unwanted harmonic components generated by the VSI action. Higher orders harmonic components distort the compensated output voltage. The unnecessary switching harmonics generated by the VSI must be removed from the injected voltage waveform in order to maintain an acceptable Total Harmonics Distortion

C. Storage Devices/ESS

This is required to provide active power to the load during deep voltage sags. Lead-acid batteries, flywheel or SMES can be used for energy storage. It is also possible to provide the required power on the DC side of the VSI by an auxiliary bridge converter that is fed from an auxiliary AC supply. The sc need real power for compensation purpose during voltage disturbance in the distribution system. In this case the real power of the sc must be supplied by energy storage device when the voltage disturbance occurs. The energy storage device such as battery is responsible to supply an energy source in D.C form.

A VSC is a power electronic system consists of a storage device and switching devices, which can generate a sinusoidal voltage at any required frequency, magnitude, and phase angle.

D. DC Charging Circuit

The dc charging circuit has two main tasks.

- (i) The first task is to charge the energy source after a sag compensation event.
- (ii) The second task is to maintain dc link voltage at the nominal dc link voltage.

E. Principal Of Harmonic Compensation

V_s is the distorted phase voltage of upstream source side ω_0 is Fundamental Frequency, n is harmonic order, V_{0n} is zero phase sequence Voltage Component, V_{1n} & Φ_{1n} are peak and Phase value of +Ve Phase sequence Voltage Component, V_{2n} & Φ_{2n} are peak & phase of the -Ve phase sequence Voltage Component.

$$V_s = \begin{bmatrix} V_{Sa} \\ V_{Sb} \\ V_{Sc} \end{bmatrix} = \begin{bmatrix} \sum_{n=1}^{\infty} [V_{0n} + \hat{V}_{1n} \sin(n\omega_0 t + \phi_n) + \hat{V}_{2n} \sin(n\omega_0 t + \phi_{2n})] \\ \sum_{n=1}^{\infty} [V_{0n} + \hat{V}_{1n} \sin(n\omega_0 t + \phi_{n1} - \frac{2n\pi}{3}) + \hat{V}_{2n} \sin(n\omega_0 t + \phi_{2n} + \frac{2n\pi}{3})] \\ \sum_{n=1}^{\infty} [V_{0n} + \hat{V}_{1n} \sin(n\omega_0 t + \phi_n + \frac{2n\pi}{3}) + \hat{V}_{2n} \sin(n\omega_0 t + \phi_{2n} - \frac{2n\pi}{3})] \end{bmatrix}$$

The distorted phase Voltage V_{s1} is Undesirable at the sensitive load terminals. parameters of sc test system

$$V_{s1} = \begin{bmatrix} V_{Sa1} \\ V_{Sa2} \\ V_{Sa3} \end{bmatrix} = \begin{bmatrix} \hat{V}_{11} \sin(\omega_0 t + \phi_{11}) \\ \hat{V}_{11} \sin(\omega_0 t + \phi_{11} - \frac{2\pi}{3}) \\ \hat{V}_{11} \sin(\omega_0 t + \phi_{11} + \frac{2\pi}{3}) \end{bmatrix}$$

From eq 1&2

$$V_S = V_{S1} + V_{Sh} \dots\dots\dots(3)$$

Where V_{sh} is contain all Harmonic components in Eq.1

The proposed voltage injection method is to inject voltage component in series with V_s & the Desirable injection voltages would contain all harmonic component in Eq.1. Hens from eq. 1 & 2 injection voltage from sc would be

$$V_{out} = -V_{Sh} = V_{S1} - V_S$$

Where V_{out} is the injection voltage

V_{S1} is the fundamental voltage

V_S is the distorted voltage

V_{Sh} is the harmonic voltage

F. Controlled Structure Use In Series Compensation

The harmonics is generated in the load terminals using six pulse converters with fixed firing angle are connected to the main drive nonlinear load which is parallel to the sensitive load. Voltage sag is created at load terminals via a three phase fault. The above voltage problems are sensed separately and passed through the sequence analyzer. The magnitude component is compared with reference voltage (Vref). Pulse width Modulation (PWM) control technique [6] is applied for inverter switching so as to produce a three phase 50 Hz sinusoidal voltage at the load terminals. Chopping frequency is in the range of few KHz. The IGBT inverter is controlled with PI controller in order to maintain 1 per unit voltage at the load terminals. PI controller (Proportional Integral Controller) is a closed loop controller which drives the plant to be controlled with a weighted sum of the error (difference between the output and the desired set point) and the integral of that value. One advantage of a proportional plus integral controller is that the integral term in a PI controller causes the steady-state error to be zero for a step input. PI controller input is an actuating signal which is the difference between the Vref and Vin. Output of the controller block is of the form of δ .

Output of comparator = Vref – Vin

Where (1p.u. =Base Voltage)

Vref equal to 1 p.u. voltage

Vin voltage in p.u. at the load terminals. The angle δ is provided to the PWM signal generator to obtain desired firing sequence. The sinusoidal signal Vcontrol is phase-modulated by means of the angle δ . In this way the angle δ is produced in three phases.

$$V_R = \sin(\omega t + \delta)$$

$$V_Y = \sin(\omega t + \delta + \frac{2\pi}{3})$$

$$V_B = \sin(\omega t + \delta + \frac{4\pi}{3})$$

G. Parameters Of Series Compensator

Table1: system parameter

1	Phase to phase rms voltage	440volt
2	Line frequency	50Hz
3	Source impedance	Ls=.005Mh Rs=.001ohm
4	Injection transformer ratio	1:1
5	Main drive load	1MW,100VAR
6	Sensitive load	1KW,20var
7	Inverter	IGBT based 3arms,6pulse,carrier frequency=2000HZ
8	PI-controller	Kp=0.5 Ki=50 Sampling time=50microsec

III. SIMULATION RESULT AND CONCLUSION

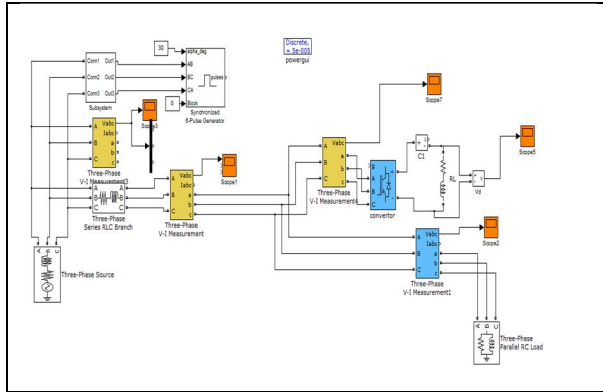

Fig(2)simulink model without series compensation

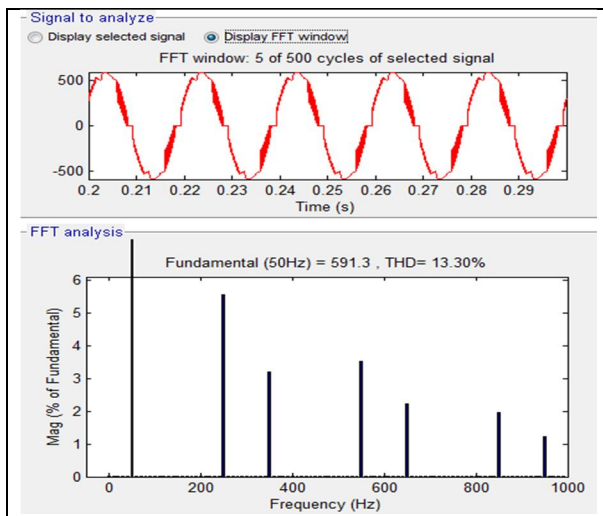

Fig(3)output and THD in harmonics order in phase1 withoutseries compensation

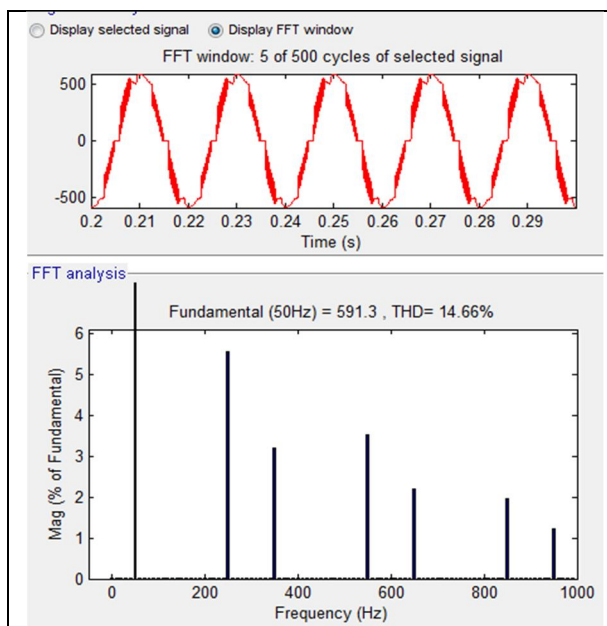

Fig(4)output and THD in harmonics order in phase2 without series compensator

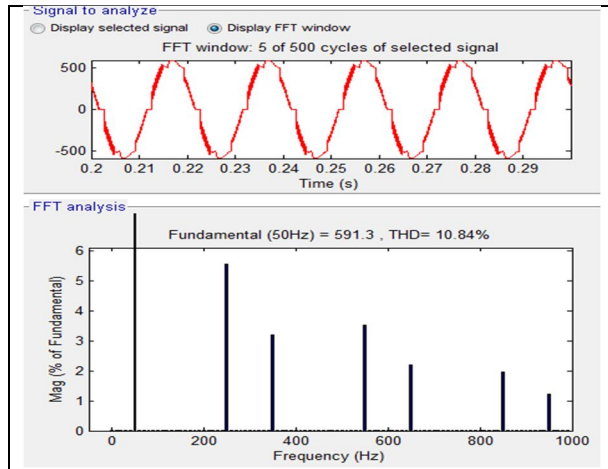

Fig(5) output and THD in harmonics order in phase3 without series compensator

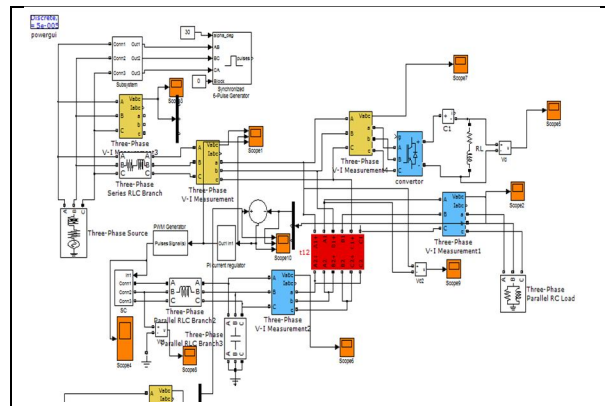

Fig(6)simulink model with series compensation

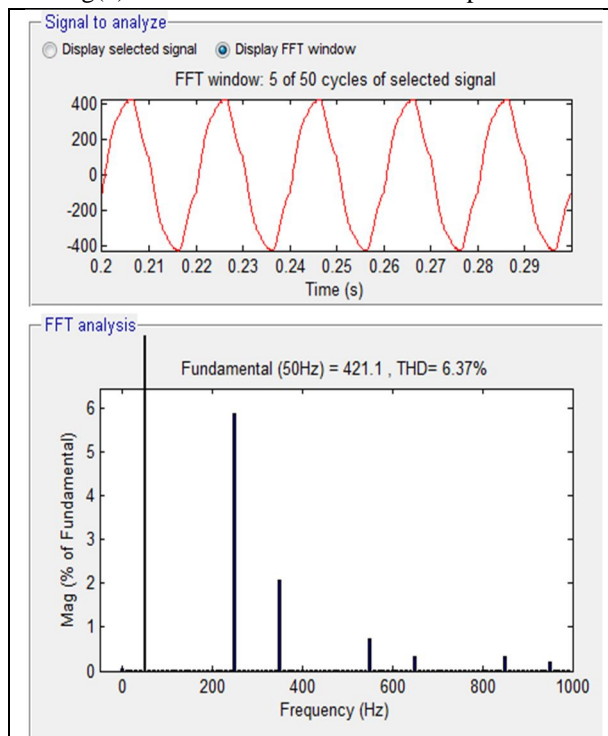
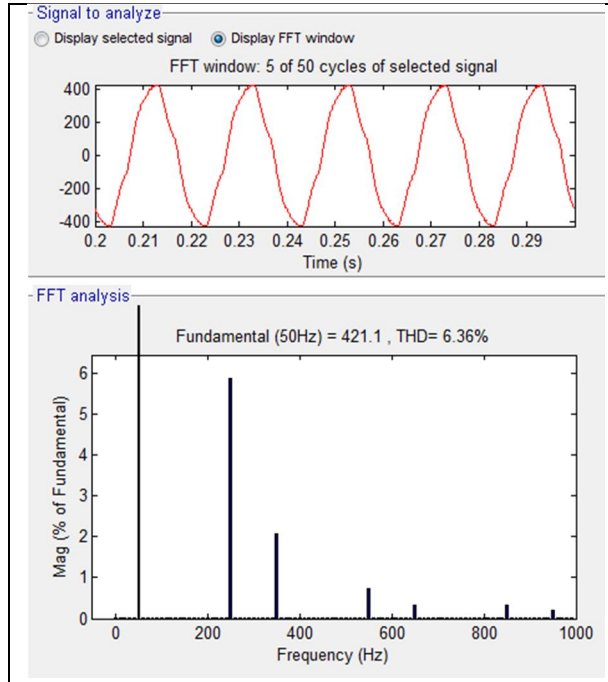

Fig (7)output and THD in harmonics order in phase1 with series compensator



Fig(8)output and THD in harmonics order in phase2 with seriescompensator

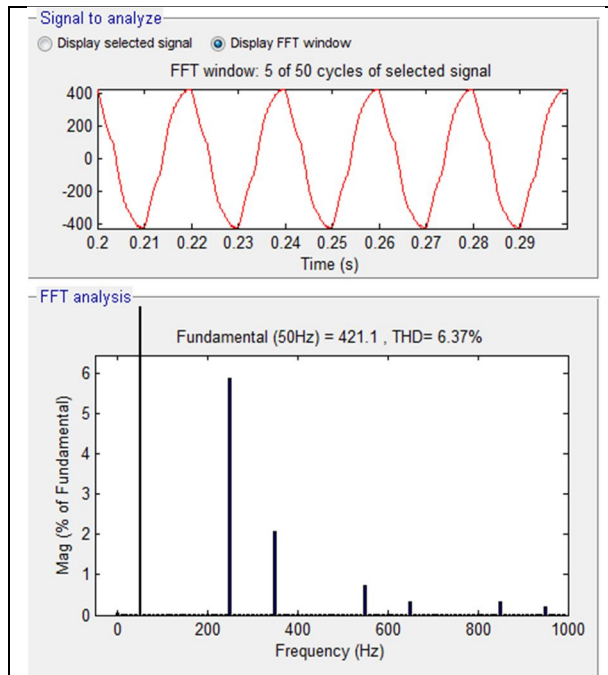

Fig (9) output and thud in harmonics order in phase1 withseries compensator

IV. CONCLUSION AND RESULT

The following tables shown the simulation result carried out with and without series compensation in mitigation harmonics

1) Without Series Compensation

SR.NO	PHASE	THD
1	Phase (a)	13.30%
2	Phase (b)	14.66%
3	Phase (c)	10.84%

2) With series compensation

SR.NO	PHASE	THD
1	Phase (a)	6.37%
2	Phase (b)	6.36%
3	Phase (c)	6.37%

Harmonics produced by the nonlinear load are harmful to the sensitive load, which is connected in parallel with nonlinear load. In the method of series compensation reduced the harmonics and increased power quality by using series compensator. Total harmonics distortion (THD) of power system is reduced with series compensation. The simulation result carried out with series compensator. the percentage of harmonics distortion in the sensitive load side in phase(a) 6.37%.in phase(b)6.36%.in phase (c)6.37% shows using FFT analysis fig(7,8&9).the generated harmonics is reduced approximately 50% as compare to without series compensator

REFERENCES

- [1] Roger C. Dugan, Mark f. Mcgranaghan, Dr. Surya Santoso and H. Wayne Beaty., "Electrical power systems quality", Tata McGraw Hills publications, 2002
- [2] Choi, S.S., Wang, T.X., and Sng, E.K.: "Power quality enhancement in an isolated power system through series compensation". Proceedings of 15th Power System Computation Conference, Liege, Belgium, August 2005,Section 22, pp.1-7
- [3] Wang.T.X. and Choi S. S.," Enhancement of Voltage Quality in Isolated Power Systems" IEEE Transactions on power delivery, Vol. 22, No.2, April2007.
- [4] Rosli Omar, NasrudinAbd Rahim, Marizan Sulaiman" Modeling and Simulation for Voltage Sags/ Swells Mitigation using Dynamic Voltage Restorer (DVR)" Journal of Theoretical and Applied Information Technology, Vol.5, No. 4, 2009, pp-464-470.
- [5] S.Sadaiappan,Modelling and simulation of series compensator to mitigate power quality problem,IJESTVol. 2 (12), 2010, 7385-7394
- [6] Dr. Devarju T. Dr. veera reedy V. C Dr.Vijayakumar.M, "Modeling and simulation of customer power devices to mitigate power quality problems" International Journal of Science and Technology, Vol. 2(6), 2010, pp.1880-1885.
- [7] S. S. Choi, B. H. Li, and D. M. ilathgamuwa, —Dynamic voltage restoration with minimum energy injection,I IEEE Trans. Power Syst., vol. 15, no. 1, pp. 51–57, Feb. 2000.



10.22214/IJRASET



45.98



IMPACT FACTOR:
7.129



IMPACT FACTOR:
7.429



INTERNATIONAL JOURNAL FOR RESEARCH

IN APPLIED SCIENCE & ENGINEERING TECHNOLOGY

Call : 08813907089  (24*7 Support on Whatsapp)