



iJRASET

International Journal For Research in
Applied Science and Engineering Technology



INTERNATIONAL JOURNAL FOR RESEARCH

IN APPLIED SCIENCE & ENGINEERING TECHNOLOGY

Volume: 11 Issue: 1 Month of publication: January 2023

DOI: <https://doi.org/10.22214/ijraset.2023.48748>

www.ijraset.com

Call:  08813907089

E-mail ID: ijraset@gmail.com

Fault Detection and Protection of Power Transformer Using Fuzzy Logic

Babagana Ali Dapshima¹, Yasmin Chuupa Essa², Dr. Saumya Chaturvedi³

^{1,2}School of Computer Science and Engineering, Department of Software Engineering

³Associate Professor, School of Computer Science and Engineering, Sharda University India

Abstract: Power transformer malfunctions cause significant power outages and, as a result, material damage. This critical issue must be resolved. Power transformers must be protected from various fault conditions and power system failure. Fuzzy logic is used in this study to detect and protect power system transformer faults. In the simulation system that diagnoses transformer faults and monitors its operating conditions, the fuzzy logic (FL) toolbox in MATLAB/ SIMULINK software was used. The input variables, current and rate of change of current with time, have been identified as "Error" and "Error-Dot" in the programme. The study's findings show that when the output response is zero, the current in the transformer is normal. This is obtained by injecting [0] and [0] input values into the system, resulting in a response of "6e(-017)," which is close to zero. If the output response is greater than zero, the transformer current is rising above normal and the protection scheme should be notified. This condition is achieved by giving the system input values of [-1.5] and [5] and expecting a response of "+5". If the response is less than zero, the transformer current is less than normal, and the protection scheme should be notified. The study concluded that electrical faults and mechanical failures in power transformers can be quickly identified using Fuzzy logic. Thus, power transformer damage is avoided by controlling relays more effectively and quickly. This has resulted in significant savings in maintenance and repair costs. It is assumed that the study was a success.

Keywords: Fuzzy logic, Transformer, fault, Detection, Current, Protection

I. INTRODUCTION

Power transformers are power system's most expensive and important elements. Malfunctions in power transformers may result in significant power cuts and, material damage. This important problem needs to be solved. Power transformers must be protected from various fault conditions and faults in the power system. High voltage transformers are unavoidably subject to various faults and relays like differential and directional relays with sensors are usually adopted to detect and transmit the decision to a circuit breaker that trips or opens the power system. Ahmed *et al* (2013). These modern detection schemes do not tolerate uncertainties or impressions under changing operating conditions. Hence, the use of fuzzy logic in fault detection and protection in power transformers came into the limelight.

Fuzzy logic as an alternative method of fault detection and protection on power transformers has been adopted for this research. Soft computing has been proposed as a method to solve real-world problems, which defies conventional approaches even when expert knowledge is available, it is often more easily stated in a descriptive form that is, a statement like "IF a sign of a certain type appears THEN one or more faults must be present" Parihar, V (2017).

II. REVIEW OF RELATED LITERATURE

A lot of research work has been carried out on fault detection on power transformers which is mainly centered on how to use alarms and protection relays in order to develop a more efficient and precise faults detection system in power system networks. incorporate artificial intelligent approaches which process the information from alarms and protection relays in power distribution and transmission systems.

A system has been designed in cooperation with Supervisory Control and Data Acquisition (SCADA) to develop a more reliable, efficient, and precise fault diagnosis in the transmission line. Barbosa, D. (2019). These system detects faults' location, its causes and identifies unwanted operations of protection devices. Various methods such as voltage and current sensors were used on power system lines to obtain real-time implementation, thus this process involves high cost. An artificial Neural Network (ANN) based program written with MATLAB 7.5 environment which was used for the analysis of fault and detection in power systems has been developed to locate faults. Lekie, A. (2018).

Alarm relays were used to obtain faults and faults locations in lines and bus sections in the power system. A research on extended fault-location formulation for power distribution systems was conducted and the proposed method used is the voltages and currents as input data for fault detect the fault Alsafasfeh et. al. (2010).

Dustegor, D (2010) reviewed how model-based fault detection and location approach of structural analysis can be used to meet the needs of power systems, thus, challenges as a result of increased in system complexity make conventional protection schemes impractical. Similarly, Sujatha, M.S., (2011) conducted an On-Line Monitoring and analysis of Faults in Transmission and Distribution Lines using GSM technique, Ghorbani, J., (2012) reviewed a decentralized multi agent system (MAS) which operates based on real time power for fault detection applications. The agents use were local voltage and current RMS values to locate a fault. Faig, J., (2010), also proposed the location of single-phase faults in power distribution systems with distributed generation using impedance-based methods.

Recently, several research was conducted on automated fault location in the distribution system. Thus the fault detection and location on high-voltage Distribution lines were still not satisfied. Walid (2016), came up with a general approach to locate any type of fault on either a single-circuit or a double-circuit transmission line when only current magnitude measurements are available.

Ashrafian A (2016) reviewed the concept of voltage sags profiles in the location of faults. However, strength and limitation were observed when the method was applied for loading variation, load models and different fault resistances. Mohammed A. (2013), also proposed travelling Waves for finding the fault Location in Transmission Lines. This wavelet provided multiple resolutions in both frequency and time domains. In this method, faults were identified using the return time of the pulse wave. Frantisek, et al. (2007), presented a novel approach in the distribution protection technique of fault line selection based on analysis of generated transient and the potential of using discrete wavelet transform in the protective relay was examined. Artificial Intelligence-based techniques model with highly complex processes was adapted in order to formulate solutions to open-ended problems, in situations where traditional approaches cannot be applied. Among the Artificial Intelligence based techniques adapted is, Artificial Neural Networks (ANNs) Sarvi, S. et al., (2012). However, the tools proposed did not meet expectations as they exhibit limitations regarding poor resolution and magnitude of the training set.

Several research had been carried out on line protection using well-defined computational mathematical methods that were not intelligent enough but in recent years intelligent-based methods are being used in fault detection among which is the fuzzy logic system.

A. Faults In The Transformer

The power transformer is a major and very important component of the power system. Also, the possibility of a fault in a transformer is rare compared to a generator, but it must be disconnected as quickly as possible if the fault occurs. It requires highly reliable protective devices. Usually, different types of fuses were used for the protection of almost all distribution transformers. While in the case of power transformers, automatic protective relaying equipment is needed for protection against possible faults.

Types Of Faults In Transformers

There are various types of faults in the transformer namely;

- 1) *Auxiliary Equipment Faults*: These are types of faults as a result of failure in the transformer. winding. Such kinds of faults came into being due to winding and core insulation, gas cushion, and drop-in transformer oil.
- 2) *Winding And Connection Faults*: These types of faults are serious in nature because they cause immediate damage to the transformer. It usually occurs due to faults between turns, damage to insulation due to overload, etc.
- 3) *External Short Circuits And Overload Faults*: Insulation of the windings is mostly affected by the loads applied to the transformer. External short and overload faults usually give raise the temperature of the windings and cooling system. Such kinds of faults and be checked by monitoring the winding and oil temperature.

B. Fuzzy Logic

Fuzzy logic is an approach that uses a sets of rules which define it behaviour. It is a heuristic, which makes it possible to obtain an array of accurate conclusions using IF-THEN statements. Fuzzy logic rules replace formulas which are used in solving computational problems. The rule covers all situations that may occur but they yet should be written in every possible combination Husain, Z. (2018). In fuzzy logic, each rule insert it input and determine it appropriate output. The output obtained from the individual rules are merged together into a single term called logic sum.

Fuzzy logic rules replace formulas that are used in solving computational problems. The rule covers all situations that may occur but they yet should be written in every possible combination. In fuzzy logic, each rule inserts input and determines its appropriate output. The output from the individual rules is merged into a single term called logic sum. The fuzzy control system uses a collection of fuzzy membership functions to implement its process. This is done by transforming the Crisp value into a fuzzy value which is used to apply rules formulated by linguistic expression. Then, the fuzzy system modifies the linguistic conclusion back to a crisp value as described by the block diagram shown in Fig 1.

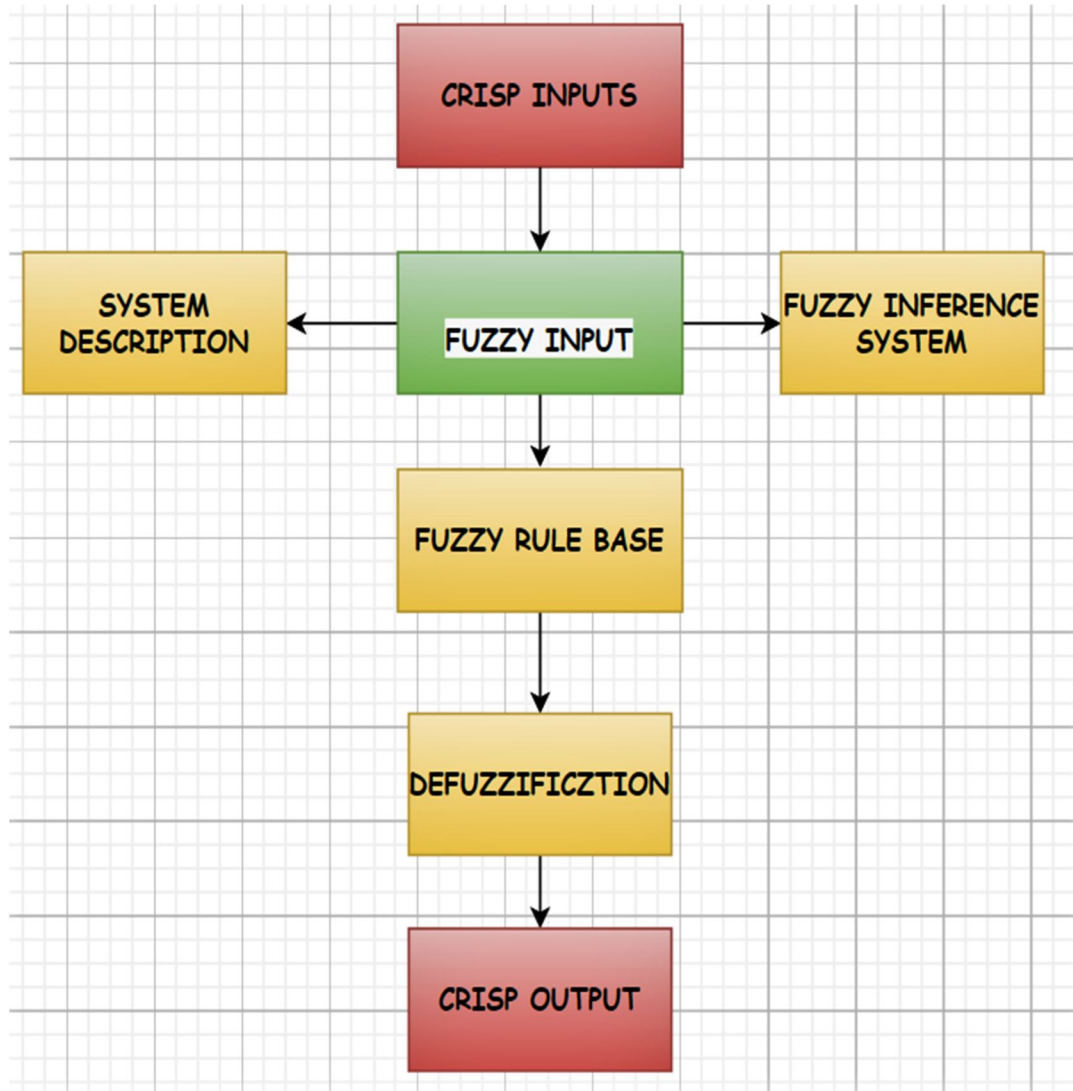

Figure 1: Fuzzy logic control system

These steps are described as follows:

- 1) *Fuzzification*: Crisp input values are converted to degrees of memberships, and matched with the rules' conditions to determine how well the condition of each rule matches that particular input.
- 2) *Fuzzy-Rule Base*: The collection of rules is called a rule base. The truth value for the premise of each logic rule is computed and applied to the conclusion part of each rule. This results in one fuzzy set being assigned to each output variable for each rule.
- 3) *Inference System*: Inference from a set of fuzzy rules involves fuzzification of the conditions of the rules, then propagating the membership values of the conditions to the outcomes of the rules.
- 4) *Defuzzification*: Fuzzy concepts involved in the conclusion of the fuzzy-rule set are translated back into object terms before they can be used in practice. To do this membership functions must be defined.

III. METHODOLOGY

This paper investigates the feasibility of using fuzzy logic method to predict and detect faults at early stage in distribution transformer. The fuzzy logic based detector has been developed to monitor and predict faults at an early stage on transformer. The diagram shown in figure 1 clearly show an improved fault detection and protection for a transformer using fuzzy logic fault detector.

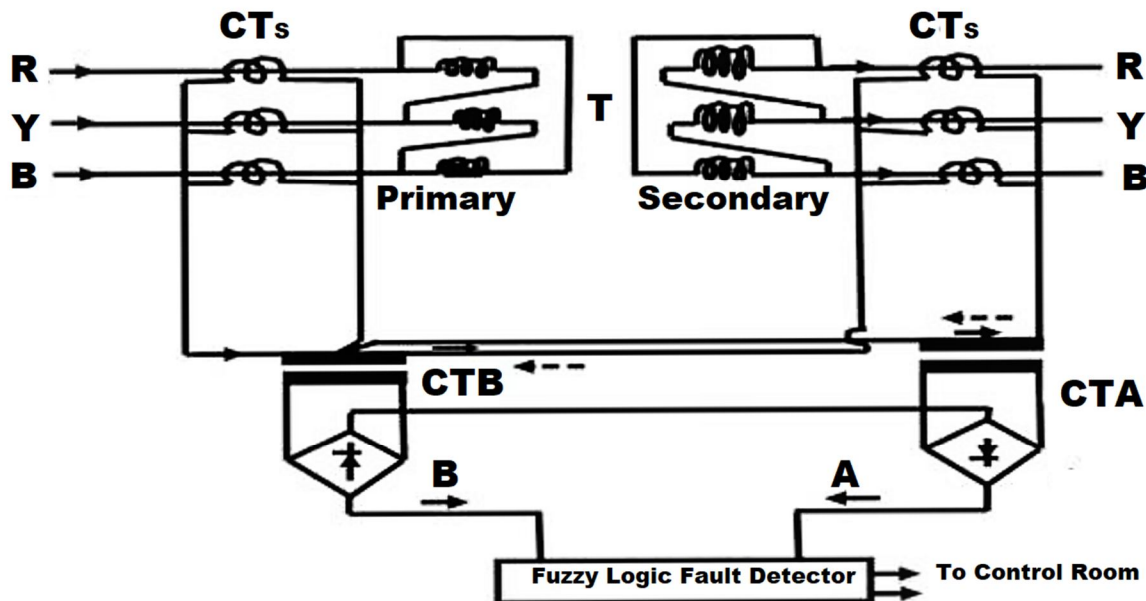

Figure 2: Improve Circuit For Detection using fuzzy logic

From the circuit in figure 2.

IA = Operating current in the transformer

IB = Restraining current in the transformer

CTA = Auxiliary current at the operating side of the transformer.

CTB = Auxiliary current at the restraining of the transformer.

R, Y and B are lines voltages in the power transformer

CTs is the current in the power transformer.

T = Transformer Protection.

From the transformer High Voltage (HV) side,

$$\text{Current } I_1 = \frac{\text{MVA}}{\sqrt{3} \text{ MV}} \text{ or } I_1 = \frac{\text{KVA}}{\sqrt{3} \text{ MV}}, \quad \frac{I_1}{I_2} = \frac{N_2}{N_1}, \quad I_2 = I_1 \times \frac{N_2}{N_1} = \text{Input of current (error).}$$

Note that I_2 , the transformer's output current, becomes the fuzzy detector's input current "Error," while $\frac{dI_2}{dt}$ the output current at time t , becomes the second input current error-dot.

The circuit in Figure 1 illustrates the circulating-current backup system for a 3-phase delta/delta power transformer. Bear in mind that the CTs on the transformer's 2 sections are connected in a star pattern.

These offset the phase difference between the secondary and primary of the transformer. The current on the power transformer is attached to the fuzzy logic fault detector to provide protection. The differential relay is connected equally. The differential circuit compares the currents at both side of the transformer.

In the operating and restraining current circuits, an auxiliary CTA and CTB are connected. The rectifier bridge comparator is connected to the secondary of these auxiliary CTs. The output of the operating auxiliaries CTA and CTB is fed into Rectifier Bridges A and B, whose output values provide forward currents to the fuzzy logic detector as inputs 1 and 2.

These input values were also fuzzified one after the other in accordance with the rule structure. As illustrated in Figure 1, the initial results of each input value are fed back into the system and to the controller via the rectifier. Similarly, these input values are fuzzified logically to produce output response values, depending on the number of possible fuzzy rules.

Based on the research objectives which is detect and protect faults in power transformer, the fuzzy logic detector only requires external measurement taken from the input and output nodes of the transformer as shown in Figure 2.

The measurement obtained from the transformer input and output will be processed by the fuzzy logic controller available in MATLAB Tool Box.

In essence, fault detection and protection of power transformer using fuzzy logic conducted by the following steps;

- 1) Identification of input and output variable
- 2) Construction of control rules
- 3) Fuzzification and fuzzy membership functions
- 4) Selection of composition rule of inference
- 5) Defuzzification method

For the purpose of this research, the simulation software was Simulink MATLAB. This can be accomplished by developing the system with the fuzzy logic toolbox Graphical User Interface (GUI) tools. Figure 3 depicts the five primary graphical user interface GUI tools for building, editing, and observing fuzzy inference systems in the fuzzy logic toolbox.

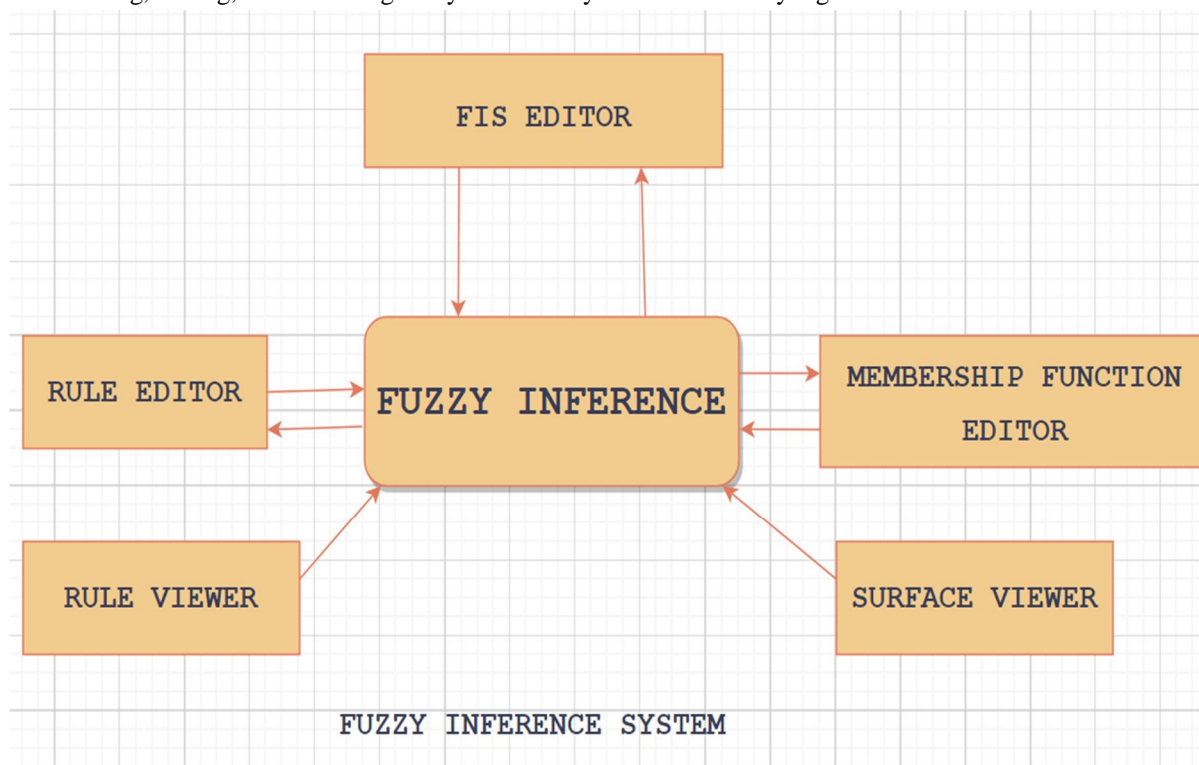

Figure 3: Fuzzy Inference System

- 1) *The fuzzy Inference System Editor (FIS Editor):* Handles the system's high-level issues: How many input and output variables are there? What are their given names?
- 2) *Membership Function Editor:* This tool is used to specify the shapes of the membership functions that are associated with each variable.
- 3) *Rule Editor:* For editing the list of rules that define the system's behaviour.
- 4) *The Rule Viewer and the Surface Viewer:* These are used to viewing the FIS rather than editing it. They are strictly read-only applications. It can display which rules are active, or how individual membership function shapes affect the results. The Surface Viewer displays the dependence of one of the outputs on any one or two of the inputs, that is, it generates and plots an equation.

IV. RESULT ANALYSIS

The following are the outcomes and simulations of this analysis: The adjectives negative big (nb), negative small (NS), zero (z), positive small (PS), and positive big (PB) modify the fuzzy parameter Current (error) (PB). The source code handles this. Error = [-1.5 1.5]. Figure 4 depicts a current simulation (input error)

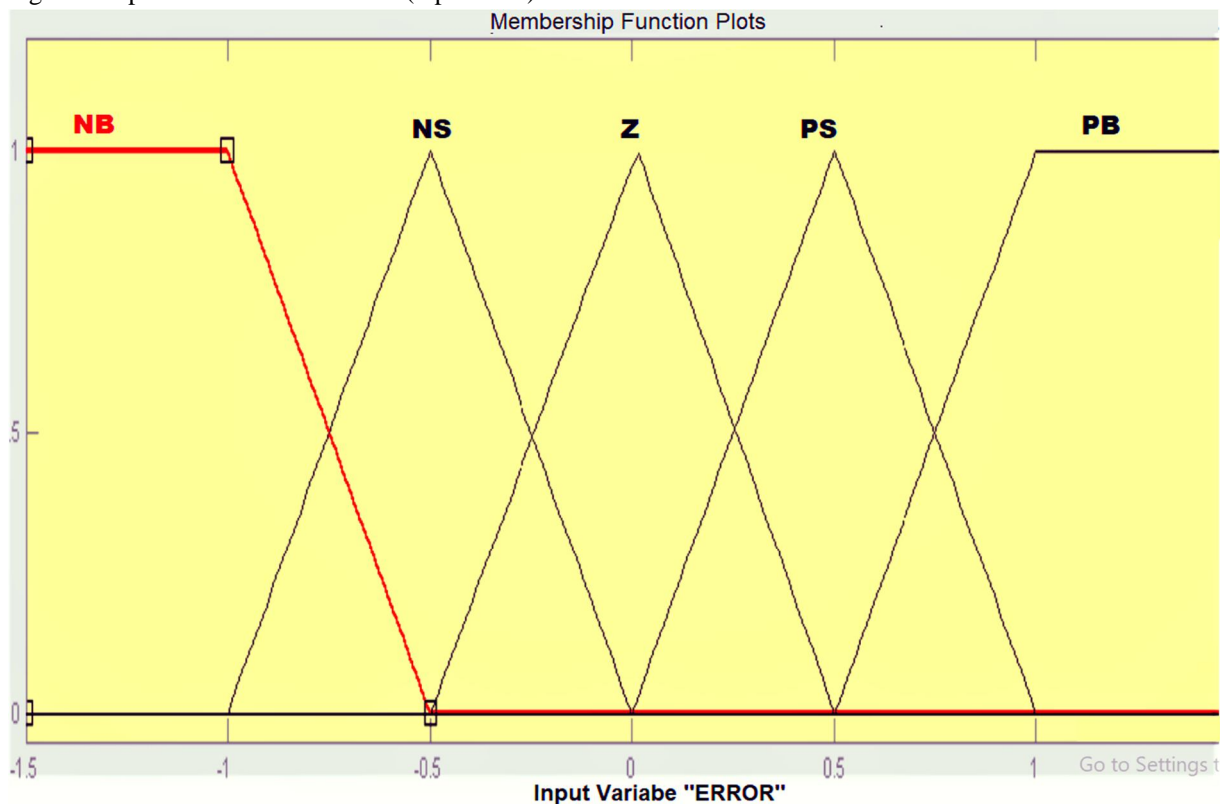

Figure 4: Error Membership Function.

The linguistic variables positive (p), zero (ze), and negative (n) influence the second fuzzy input parameter of the rate of change of error (dele-error) (n). Discrepancy = [-10, 10]. Figure 5 depicts the simulated results of the rate of change of the current Error-dot.

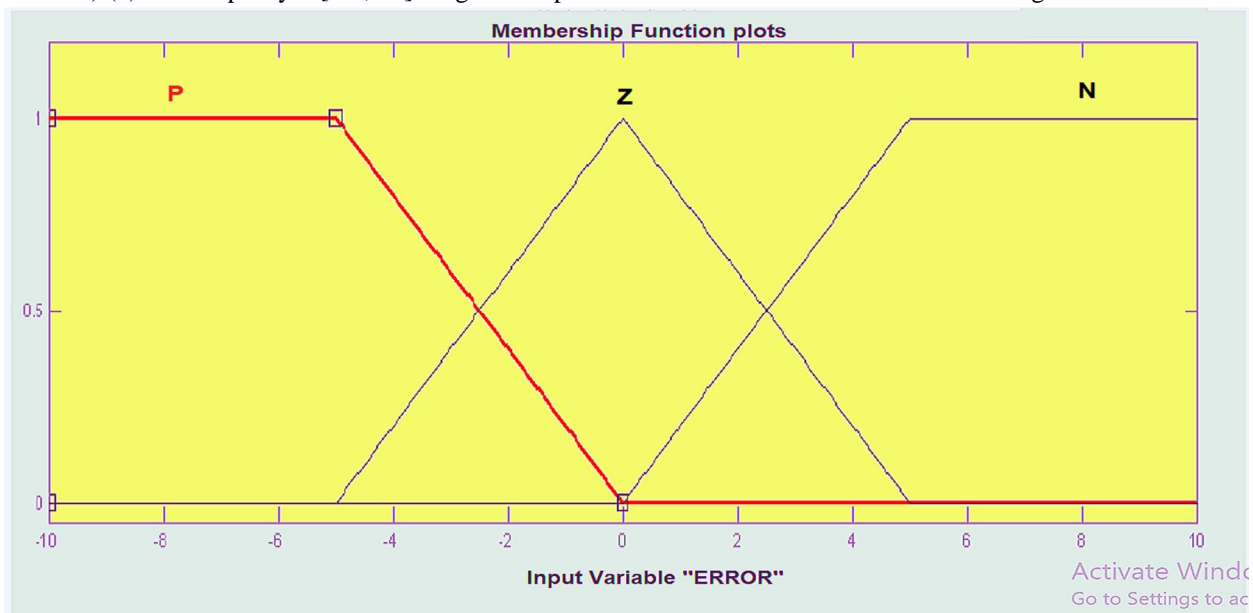

Figure 5: Error-Dot Membership functions

The linguistic variables modify the fuzzy output ("control current");

"H" stands for "High" Output response.

"NC" stands for "no change" in current output.

"L" denotes a "low" output response.

Figure 6 depicts the simulated result of the consequent of the degree of membership with which the antecedents Error and Error-dot were calculated.

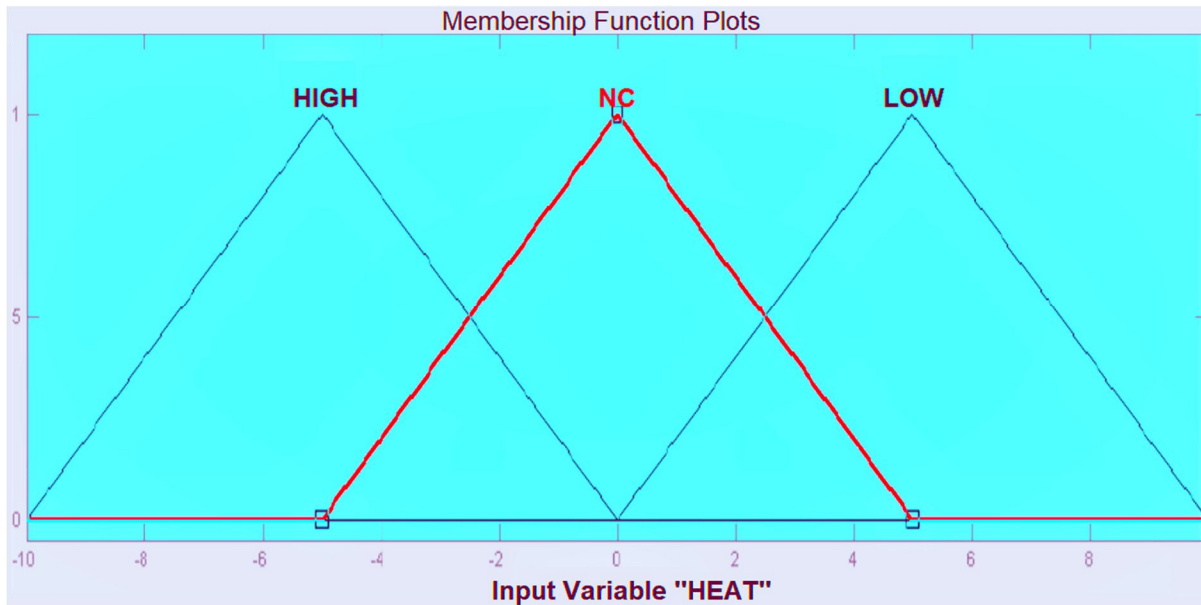

Figure 6: Fuzzy rules consequent

Figures 7a, 7b, and 7c depict the aggregation of fuzzy rule outputs and the crisp output value for current.

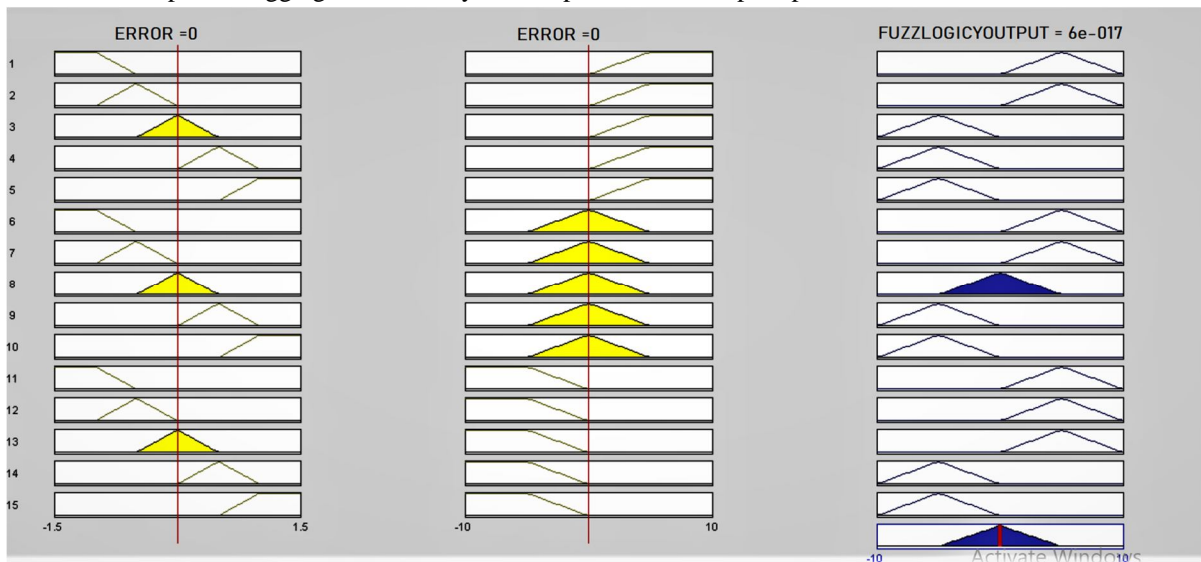

Figure 7a: Fuzzy Output Response Aggregate for "NO CHANGE"

The fuzzy output sets are aggregated to form a single fuzzy output set at input "Error" of [0] and "Error-Dot" of [0]. These error and error-dot conditions occur when the transformer's current is within the tolerable limit; thus, the system sees no input data and works with zero as input data. Under this condition, the output fuzzy set is defuzzified to find the crisp output value for the transformer Current to be "6e(-017)," implying that the system is calling for a "NO CHANGE" Output response; thus, the system is running at a normal current level.

If there is a difference between the error membership and the error-dot membership, the output will change, as shown in Figure 6b.

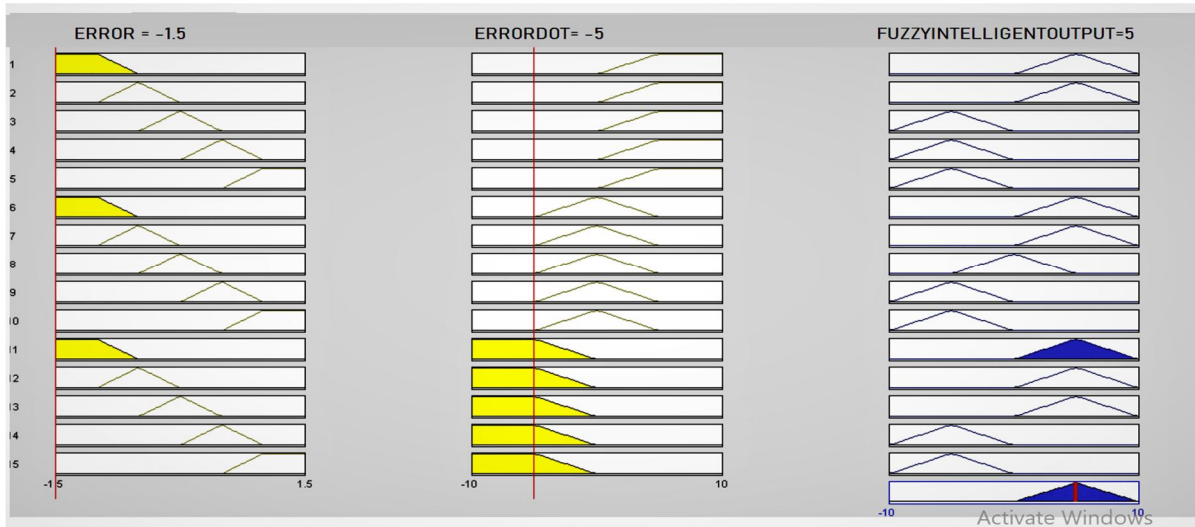

Figure 7b: Fuzzy Output Response Aggregate for "High Current"

In this result analysis, we have a crisp output = "5" after defuzzification of input "error" = [-1.5] and "error-dot" = [5], implying that the system is alerting the protection scheme because the Current may be too high.

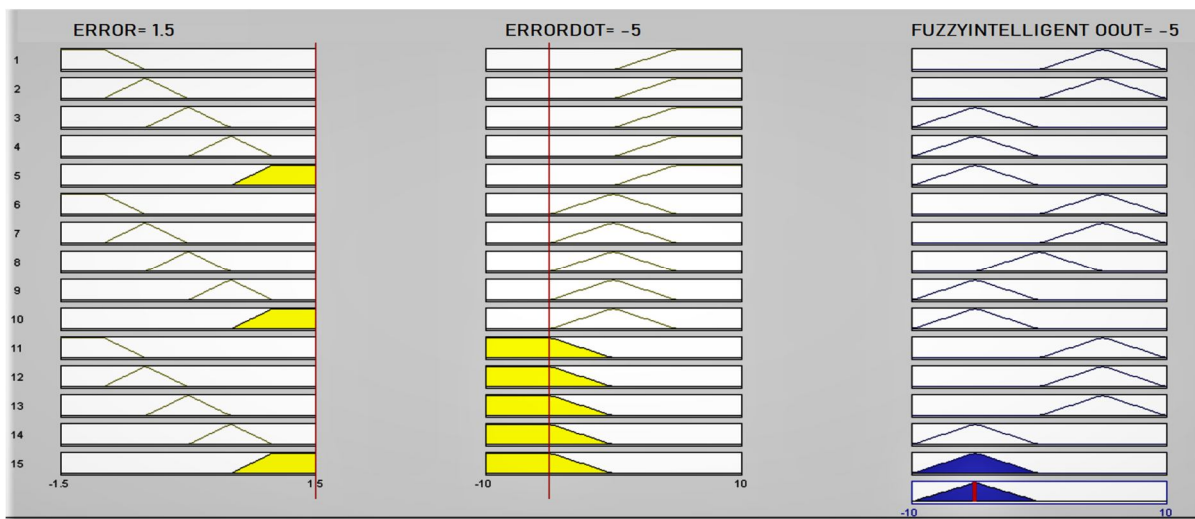

Figure 7c: Fuzzy Output Response Aggregate for "Low Current"

The simulation result of the input data "1.5" and "-5" from the analysis = "- 5," implying that the transformer has low current; thus, the detector is simply informing the control engineer that the system current is low.

V. CONCLUSION

Fuzzy logic is used in this study to detect and protect power system transformer faults. In the simulation system that diagnoses transformer faults and monitors its operating conditions, the fuzzy logic (FL) toolbox in MATLAB/ SIMULINK software was used. The input variables, current and rate of change of current with time, have been identified as "Error" and "Error-Dot" in the programme. The study's findings show that when the output response is zero, the current in the transformer is normal. This is obtained by injecting [0] and [0] input values into the system, resulting in a response of "6e(-017)," which is close to zero. If the output response is greater than zero, the transformer current is rising above normal and the protection scheme should be notified. This condition is achieved by giving the system input values of [-1.5] and [5] and expecting a response of "+5". If the response is less than zero, the transformer current is less than normal, and the protection scheme should be notified. The study concluded that electrical faults and mechanical failures in power transformers can be quickly identified using Fuzzy logic.

REFERENCES

- [1] Abdel-Akler, M. (2010). Fault analysis of multiphase distribution system using symmetrical components. *IEEE Transaction on Power Delivery* 25(4), 2931-2939
- [2] Ahmed, M. R., Geliel, M. A., & Khalil, A. (2013, June). Power transformer fault diagnosis using a fuzzy logic technique based on dissolved gas analysis. In *21st Mediterranean Conference on Control and Automation* (pp. 584-589). IEEE.
- [3] Alsafasfeh, Q., I. Abdel-Qader and A. Harb, 2010. Symmetrical pattern and PCA based framework for fault detection and classification in power systems. *IEEE International Conference on Electro/Information Technology (EIT)*. 1-5.
- [4] Ashrafian A, Vahidi B, Mirsalim M (2014) Time–time-transform application to fault diagnosis of power transformers. *IET Gen Transmission Distrib* 8(6):1156–1167
- [5] Barbosa, D. C. P., de Medeiros, L. H. A., de Melo, M. T., da Silva Lourenço, L. R. G., de Sá Coutinho, M., Alves, M. M., ... & Tarragô, V. L. (2019). Machine learning approach to detect faults in anchor rods of power transmission lines. *IEEE Antennas and Wireless Propagation Letters*, 18(11), 2335-2339.
- [6] Dustegor, D., S.V. Poroseva, M.Y. Hussaini and S. Woodruff, (2010). Automated graph-based methodology for fault detection and location in power systems. *IEEE Transactions on power delivery*, 25(2): 638-646. Sahu VK, Pahariya Y (2021) A review of various protection schemes of power transformers. *Turkish J Comput Math Educ* 12(10):7533–7541
- [7] Faig, J., J. Melendez, S. Herraiz and J. Sánchez, 2010. Analysis of Faults in Power Distribution Systems with Distributed Generation, *International Conference on Renewable Energies and Power Quality (ICREPQ'10) Granada (Spain)*
- [9] Frantisek, Janicek et al., (2007). Digitalization in power distribution systems: *Stoak University of Technology*, 2018, 89-94 ISBN 978-80-89983-00-1
- [10] Ghorbani, J., M.A. Choudhry and A. Feliachi, 2012. Real-time multi agent system modeling for fault detection in power distribution systems. *North American Power Symposium (NAPS)*.
- [11] 1-6
- [12] Husain, Z. (2018). Fuzzy logic expert system for incipient fault diagnosis of power transformers. *International Journal on Electrical Engineering and Informatics*, 10(2), 300-317.
- [13] Lekie, A. J., Idoniboyeobu, D. C., & Braide, S. L. (2018). Fault Detection on Distribution Line Using Fuzzy Logic. *International Journal of Scientific and Eng. Research*, 9(12), 490-503.
- [14] Mohammed Abdul Baseer (2013). Transient Stability Improvement of Multi-machine Power system using fuzzy logic controlled TCSC MA- Baseer – *IOSR Journal of Electrical and Electronics Engineering*, 2014.
- [15] Parihar, V. R., Nimkar, S. D., Warudkar, S., Deshmukh, R., & Thakare, M. (2017). Power transformer protection using fuzzy logic based controller. *International Journal of Engineering Research*, 6(7), 366-370
- [16] Sadeh, J. and Afradi, H. (2009). A New and Accurate Fault Location Algorithm for Combined Transmission Lines Using Adaptive Network Based Fuzzy Inference System, *Journal of Electric Power System Research*, Vol.79, No.11, 15338 -1545
- [17] Sarvi, S. et al., (2012). Gravitational Search algorithm based optimal reactive porous dispatch for voltage stability enhancement, *Electric power components and systems*, 40(9), 956-976
- [18] Sujatha, M.S., Dr. M. Vijay Kumar, 2011. On-Line Monitoring and analysis of Faults In Transmission and Distribution Lines using GSM technique. *Journal of Theoretical and Applied Information Technology*, 33(2)
- [19] Wahid, G, M, Tarlochou, S.S. (2016), A new harmony search approach for optimal wavelets applied to fault classification *IEEE Trans Smart Grid*.



10.22214/IJRASET



45.98



IMPACT FACTOR:
7.129



IMPACT FACTOR:
7.429



INTERNATIONAL JOURNAL FOR RESEARCH

IN APPLIED SCIENCE & ENGINEERING TECHNOLOGY

Call : 08813907089  (24*7 Support on Whatsapp)