



# IJRASET

International Journal For Research in  
Applied Science and Engineering Technology



---

# INTERNATIONAL JOURNAL FOR RESEARCH

IN APPLIED SCIENCE & ENGINEERING TECHNOLOGY

---

**Volume:** 10    **Issue:** VI    **Month of publication:** June 2022

**DOI:** <https://doi.org/10.22214/ijraset.2022.43320>

[www.ijraset.com](http://www.ijraset.com)

Call:  08813907089

E-mail ID: [ijraset@gmail.com](mailto:ijraset@gmail.com)

# Fire Extinguisher Robot

Mr. Sarthak Dharmik<sup>1</sup>, Mr. Pankaj Rawat<sup>2</sup>, Mr. Suryakant Singh<sup>3</sup>, Mr. Gitesh Wankhede<sup>4</sup>, Dr. F.B. Sayyad<sup>5</sup>

<sup>1, 2, 3, 4</sup>Department of Mechanical Engineering, Dr. D. Y. Patil School of Engineering, Lohegaon,

<sup>5</sup>Guide

**Abstract:** A fire outbreak is a hazardous act that leads to numerous consequences. Detecting a fire at an early stage and extinguishing it can aid in prevention of various accidents. Till now we rely on human resource. This often leads to risking the life of that person. Therefore, fire security becomes an important aspect to save human lives. In this paper a fire extinguishing robot has been proposed and designed which detects the fire location and extinguish fire by using sprinklers on triggering the pump. This robot uses three flame sensors for accurate fire detection. This proposed model of Fire Extinguishing Robot using Arduino used to detect presence of fire and extinguishing it automatically without any human interference. It contains gear motors and motor driver to control the movement of robot when it detects any presence of fire and will automatically start the water pump to extinguish that fire breakout. This model robot has a water ejector which is capable of ejecting water at the fire breakout place. The water ejector pipe can be move towards the required direction using servo motor. The whole operation is controlled by an Arduino UNO micro-controller.

**Keywords:** Arduino UNO, Flame sensor, Motor driver.

## I. INTRODUCTION

### A. Problem Statement

Firemen are more vulnerable to death in the course of their daily routine of firefighting. The time factor is a problem in a fire situation. Fire caused by gas leak and chemical oil could cause an explosion, so dangerous to human life. The use of robot is one of the alternative medium for reducing firemen casualties and enhancing fireman capabilities.

### B. Objectives

We aim to design a robot capable of detecting and suppressing fires and reducing the efforts of human labour and level of destruction. By designing and implementing an autonomous robot capable of detecting and extinguishing flames, disasters can be avoided with minimal risk to human life.

### C. Scope

This project has been motivated by the desire to design a system that can detect fires and intervention. This provides us the opportunity to pass on to robots tasks that traditionally humans had to do but were inherently life threatening. Fire-fighting is an obvious candidate for such automation. Given the number of lives lost regularly in firefighting, the system we envision is crying for adoption. Of course, this project has only scratched the surface. As in the design simplifications and the implementation constraints in suggest, our project is very much a proof-of-concept. In particular, a practical autonomous fire-fighting system must include a collection of robots, communicating and cooperating in the mission; furthermore, such a system requires facilities for going through obstacles in the presence of fire, and ability to receive instructions on-the-fly during an operation. All such concerns were outside the scope of this project. However, there has been research on many of these pieces in different contexts, e.g., coordination among mobile agents, techniques for detecting and avoiding obstacles.

### D. Methodology

An Arduino based algorithm is used to detect fire and measure distance from fire source while the robot is on its way to douse fire. When the fire is detected and the robot is at a distance close to the fire, an electronic motor throws water for extinguishing fire.

## II. LITERATURE REVIEW

In today's era fire fighting is an dangerous issue. Many authors are working on different techniques for fire fighting. Author Ratnesh Malik et al. has developed an approach towards fire fighting robot. The robot is designed and constructed which is able to extinguish fire. The robot is fully autonomous.

It implements the concept like environmental sensing and awareness, proportional motor control. The robot processes information from its sensors and hardware elements. Ultraviolet, Infrared and visible light are used to detect the components of environment. The robot is capable of fighting tunnel fire, industry fire and military applications are designed and built. Ultraviolet sensors are used to detect fire. Once fire is detected, robot sounds an alarm. Then the robot activates an electronic valve which release sprinkles of water on the flame. Detailed concept of robot is explained which automatically detects fire and extinguishes it in short time by the use of sensors, microcontroller etc. This robot is used in places where human lives are at high risk .

Author Kristi Kokasih et al. has developed intelligent fire fighting tank robot. Tank robot is made from acrylic, plastic, aluminum and iron. Robot components are two servo motors, two DC motors, ultrasonic sensor, compass sensors, flame detector, thermal array sensor, white detector (IR and photo transistor) , sound activation circuit and micro switch sensor. The objective is to search certain area, find and extinguish the flame for different flame positions, room configuration with disturbance. Robot is activated through DTMF transmitter and receiver .

Control Of An Autonomous Industrial Fire Fighting Mobile Robot is developed by H.P. Singh et al. The paper describes the construction and design of mobile fire fighting robot. The system contains two optically isolated D.C. motors. Robot performs analog to digital conversion of the data provided by infrared sensors. Five infrared sensor are used. Two sensors control the motion of the robots and three are for flame detection. The extinguisher comprises of D.C water pump and a water container. The basic theme of the paper is to sense the flames of fire and extinguish it. For this infrared sensor is used as input sensor which senses the infrared rays coming out of the fire. The microcontroller controls the extinguishing system.

Wireless fire fighting robot is developed by Swati Deshmukh et al. It comprises of machine which has ability to detect fire and extinguish it. The fire fighting robot can move in both forward and reverse direction and can turned in left and right directions. Thus fire fighter can operate the robot over a long distance and there is no need for human near the area on fire. Light dependent resistors are used for detection of fire. These resistors are highly sensitive devices and are capable of detecting very small fire. The robot provides security at home, buildings, factory and laboratory. It is an intelligent multisensory based security system which contains fire fighting system in daily life.

Cell phone controlled robot with fire detection sensors developed by Lakshay Arora consist of mobile phone which controls a robot by making a call to the mobile phone which is attached to the robot. During the call activation period, if any button is pressed on the phone, the tone corresponding to the button pressed is heard at the other end of the call that is placed on the robot. The robot perceives Dual-Tone Multiple-Frequency (DTMF) tone with the help of phone mounted on the robot. The received code is processed by the microcontroller and then the robot performs actions accordingly. In the proposed system DTMF technology is used to position the shaft of motor at a required point with different sensors, each performing its own task. Rugged, Simple and cost effective system is proposed here.

Android Phone controlled Robot Using Bluetooth is developed by Arpit Sharma et al. Various techniques of Human Machine interaction using gestures are presented. Gestures are captured by using the accelerometer. The paper analyses the motion technology to capture gestures using an android smart phone which has inbuilt accelerometer and Bluetooth module to control kinetics of the robot. The microcontroller controls the signals of the Bluetooth module. Features like user friendly interface, lightweight and portability OS based smart phone has overtaken the sophistication of technologies like programmable glove, static cameras etc making them obsolete.

Author SaravananP has designed and developed an Integrated Semi-Autonomous Fire Fighting Mobile robot. The System controls four D.C. motors powered by Atmega2560 and controlled autonomously by navigation system. Navigation system comprises of integrated ultrasonic sensors and infrared sensors. The robot is fitted with wireless camera which captures the video and transmits it to the base station. The fire detection comprises of LDR and temperature sensor. If there is a fire the sensor detects it and the robot will be moved to the source and extinguishes it. The extinguishing system consists of a BLDC motor with water container. The SABOT can be operated manually for extreme conditions. It comprises of a GUI support through which robot can be controlled from the base station.

Intelligent Fire Extinguisher System is developed by Poonam Sonsale et al. The paper proposes of an adaptive fusion algorithm for fire detection. It uses a smoke sensor, flame sensor, temperature sensor for fire detection. It contains intelligent multisensory based security system that contains a fire fighting system in daily life. The security system can detect abnormal and dangerous situation and notify. Intelligent buildings are expected to be safer convenient and efficient living environments for society. The purpose of Intelligent Fire Extinguisher System is to extinguish flame in a certain amount of time. The system detects the fire location and extinguish fire by using sprinklers. As being Intelligent System, it cuts off the electricity of area where fire has been caught and starts the sprinklers only of that area.

Remote Controlled Fire Fighting Robot developed by Phyo Wai Aung describes the functions of remote control fire fighting robot. It contains two main parts that is transmitter and receiver in which two sets of RF modules are used. One RF module is used to transmit the data to the motor driver and another RF module is used to know the condition on fire. Microcontroller PIC16F887 is used operate the whole system of the fire fighting robot. The motors are driven by the L298 and ULN2003 drivers in this system. The operator controls the robot by using wireless camera mounted on the robot. If the temperature of fire sight is above 40 degree Celsius, the alarm will be ringing so that operator can control the fire fighting robot and avoid the damage of heat.

To design and build a small Fire Fighting robot, where a robot will be put in a house model where a light candle is available and the robot should be able to detect, and extinguish the candle in the shortest time while navigating through the house and avoiding any obstacles in the robot's path. Researches were done in the beginning of the project to get more information about robotics in general and to think about the design, hardware components, and the software technique which will control the robot. This robot contains Light Sensor, 2 DC motors, and Buzzer is used in the robot's body. Two DC series motors are used to control the rear wheels and the single front wheel is free. The software part of the project is the program code written in the micro-controller to control the Fire Fighting Wireless Controlled robot Using 8051.

Detecting the fire and extinguishing it is a dangerous job and that puts lives of fire fighters at risk. There are number of fire accidents in which fire fighter had to lose their lives in the line of duty each year throughout the world. Increase in the number fire accidents are due to expanding human population and growing industrialization. The physical limitations of humans to deal with these kinds of destructive fires make fire extinguishing a complicated task. The use of fire fighting robots can reduce the errors and the limitations that are faced by human fire fighters. This paper contains various methods for implementation of fire fighting robots. Here we compare various design and construction of building a fire fighting robot.

When we the field of firefighting has long been a dangerous one, and there have been numerous and devastating losses because of a lack in technological advancement. Additionally, the current methods applied in firefighting are inadequate and inefficient relying heavily on humans who are prone to error, no matter how extensively they have been trained. A recent trend that has become popular is to use robots instead of humans to handle fire hazards. This is mainly because they can be used in situations that are too dangerous for any individual to involve themselves in. In our project, we develop a robot that is able to locate and extinguish fire in a given environment. The robot navigates the area and avoids any obstacles it faces in its excursion. Hear about robots, we think of science fiction novels and sci-fi movies. It is due to the fact that we do not know how to create robots of high intelligence.

Over last few decades, some the systems have been developed, namely "Fire Extinguishing Robot" and "A smart fire extinguisher using fire fighting robot" in which black line path is assigned so following those path robots were used to extinguish the fire. Also, robots are designed as tank robot with the flame, ultrasonic, thermal array, and compass sensor. Its simulation area is designed in miniature, it's miniature equipped with furniture, sound damper, and uneven floor. But the use of various sensors makes the design complicated, there will be a possibility of messing up the output. This system is fully automated fire fighting robot which deals with the fire problems in the household, laboratories, small scale industries. We can use this robot to perform those tasks that may be harmful and dangerous to humans. From the literature review it is clear that to solve problems created while operating the robot manually or through coding, intelligent design is made which constitutes addresses of various locations. This makes human life easier and reduces the efforts taken by them. This system composed of an IR sensor to detect the flame from the surrounding environment based on the data from sensors, because its speed and accuracy are better than gas and smoke sensor.

J. Reinhart V. Khandwala (2003) was et all discussed about design and the implementation of the firefighting robot. The key design elements of the robot to be discussed include: the assembly and construction of the robot hardware, the processing algorithm based on the sensors response, and the navigation algorithm that will enable the robot to find an efficient path in and out of the house model.

Lynette Miller Daniel Rodriguez (2003) was all discusses the development of each component of the robot that is designed to find a small fire represented by a light emitting diode in a model home and extinguish it. This paper will talk about each component of the robot from the start signal to the robot platform to the line following and room finding and finishing with the fire detection.

Sahil S.Shah (2013) was all discussed about design a FIRE FIGHTING ROBOT using embedded system. A robot capable of fighting a simulated household fire will be designed and built. It must be able to autonomously navigate through a modeled floor plan while actively scanning for a flame. The robot can even act as a path guider in normal case and as a fire extinguisher in emergency. Robots designed to find a fire, before it rages out of control, can one day work with fire-fighters greatly reducing the risk of injury to victims. The result shows that higher efficiency is indeed achieved using the embedded system.

U.Jyostna Sai Prasanna, M.V.D.Prasad (2013) was design the fire detection system using four flame sensors in the firefighting robot, and program the fire detection and fighting procedure using sensor based method. The firefighting robot is equipped with four thermistors/flame sensors that continuously monitor the temperature. If the temperature increases beyond the predetermined threshold value, buzzer sounds to intimate the occurrence of fire accident and a warning message will be sent to the respective personnel in the industry and to nearby fire station with the GSM module provided to it.

Swati A. Deshmukh (2015) was all discussed about the fire detection system using sensors in the system, and program the fire detection and fighting procedure using sensor based method.

Saravanan P (2015) discussed about the Design and Implementation of this project is mainly based on control of Semi - Autonomous mobile robot (SA-BOT). The system controls four DC Geared motors which is powered by the Atmega2560 and controlled autonomously by Navigation system which comprises of integrated ultrasonic and infrared sensors. The bot is outfitted with wireless camera which captures the video and transmits it to the base station. The fire detection system comprises of LDR and temperature sensor, if there is a fire, the sensors detects it and the bot will be moved to the source and starts extinguishing it. The Extinguishing System comprises of a BLDC motor with water container. The SABOT can also be operated manually for extreme conditions. We have provided a GUI support through which the bot can controlled from the base station.

Abhilash Dhumatkar, Sumit Bhiogade (2015) was all Automatic Fire Fighting Robot” project employs the electrical thermostat technology for the controlling the fire 24 hrs. The system is cost effective, has a wide applications which when implement can show good and effective result. Synchronization of various equipment involve in the system i.e Thermostat Sensor, water jet, wireless remote and wireless android device WiFi enabled Camera. This is mean to simulate the real world operation of Robot performing a fire extinguishing function. Fuzzy logic provided an appropriate solution to the otherwise complex task of mathematically deriving an exact model for the non-linear control system upon which conventional control techniques could then be applied.

Hisato Ando et al (2017) submitted a paper on “Aerial Hose Type Robot for Fire Fighting” where they designed a prototype to validate the feasibility of the amount of water required to extinguish a fire, and then evaluate the reaction force and its effect on the robot.

Teh Nam Khoonet al (2012) presented a paper on “Autonomous Fire Fighting Mobile Platform” which illustrates the advancement work depending on the stage, identify for flame and smother the fire. At the point when the fire sources being recognized the fire will be speedily quenched utilizing fire smothering framework that is mounted on its stage to distinguish the fire source the contribution from fire sensors are finely tuned in connection to the encompassing zone.

Kadam.Ket al (2018) submitted a paper on “Fire Fighting Robot” designed robot which extinguishes fire. These robots are for theenterprises where possibility of unplanned fire accidents take place. The proposed vehicle can identify the flame when it goes closer to it and stifling it consequently by utilizing gas sensor and temperature sensor. It includes equip engines and engine driver to control the development of robot.

One of the major concern for both industrial and residential areas is the loss due to fire damage. Fire causes enormous damage to life and property. The first fire department was established in Korea in April 1925 and then thereafter such facility spread quickly so that nowadays the fire stations are located all over the country in all the countries. Current firefighting systems are based on humans using water guns and chemical fire repression systems. However, humans cannot work effectively in all fire environments. In this case, it is desirable to extinguish a fire quickly using fire-fighting robots. The research on fire-fighting robots has advanced in many countries recently, in order to cope with catastrophic fire related accidents. The main problem with these robots was a heat resistant body. In this model, we have tried to overcome this drawback. Here we have used asbestos to cover the body of robot in order to minimize the heat transfer to the internal circuitry. The various models and prototypes have been developed and the research is still going on to make fire-fighting robots more efficient and to overcome their drawbacks.

Among those involved in the project were Hossain, Md Anowar, Himaddri Shakhar Roy, and others. The Automatic Fire Extinguisher Robot is a hardware-based device designed to move in the direction of fire power. The robot's shield is made of calcium silicate boards that can withstand temperatures up to 300 ° C. The ends of the thermocouple are heated to a reduced temperature when the robot begins to respond to fire. The robot is used in rescue efforts during a fire when there is little chance that the military will be able to reach the affected areas. This Robot has the advantage of being able to OPEN automatically as it detects the surrounding fire, uses a thermocouple, attempts to extinguish the fire by moving through the fire. As a backup to Thermocouple, a temperature sensor is used. To pump water, IC741 is used both as an amplifier and a simulator, in combination with a thermocouple and a water pump. Robotic movement is expected using a barrier and a sensor. The image is captured and processed with the help of MATLAB.

Hemalatha K N, Pramod B N IoT-based robot is designed to support firefighters in critical situations. A fire sensor is used to detect the presence of a fireplace. The presence of flammable gases is detected by a gas sensor. Human presence is verified by the Passive Infrared Sensor. Temperature sensor transmits temperature and humidity.

The main advantage of this project is that the robot can operate on both manual and independent control systems. An IoT-based communication system is used to monitor the affected area via Wi-Fi, and detailed functions of each module are also discussed. All data is transferred to a cloud server for further analysis. Based on its performance, it has been thoroughly tested. In an emergency, do your best to put out the fire.

Sreesruthi, Ramasubramanian, Senthil Arumugam Muthukumaraswamy, et al., the ability to provide, and a single Android phone The server is designed to manage the robot on a web page and is able to monitor different web server settings. The video streaming robot will continue to take pictures with the Android phone camera. The temperature sensor will be used by a temperature monitor to monitor the temperature. In addition to rising temperatures, fires are detected using a smoke sensor. The IR sensor detects obstacles in the path of the robot. All data from the robot is delivered to the Android phone via a Bluetooth module connected to the controller, and later to a web server via remote control via a web browser. Adjustable firefighting system with small controller introduced. Test results have shown that a small controller may be the most reliable tool for controlling an institutional device.

Mittal, Shiva, Manish Kumar Rana, and others. A fire engine was created to help firefighters in real-time emergencies. The robot can extinguish the flames with water and carbon dioxide sprays and protect itself from heat using fog sprays. The study culminated in the successful development of a robot that can function as a fire extinguisher and remotely control a wireless communication channel. For guidance, the robot has a lot of control, control, and weight with a lot of torque. Several tests were performed to test the mechanical design and adequacy and performance of the robotic software. Our robot has responded as predicted in all experimental cases, demonstrating its ability to handle real world conditions successfully. Cease Fire has tanks that pump water and CO<sub>2</sub> into it and spray it into the fire. The remote control uses a transceiver that provides the maximum distance gain of up to 1.8 km with the appropriate note. The fire engine is designed to help firefighters reduce their risk of fire. It sends it to a fire extinguisher remote control, which may use an internal camera to monitor the situation. The robot's volume can be used by firefighters to communicate with victims trapped inside fire-damaged buildings. In the meantime, experiments were performed using deliberately generated flames, and the robot performed exactly as predicted. An effective robot response during fire simulations demonstrates its ability to perform with the same precision of real world conditions.

P. Anantha, Raj, and M. Srivani If the firefighting step is taken quickly, most fires do not cause significant damage. This article proposes to integrate an independent fire extinguishing robot into a standard fire protection system Internet of Things (IoT) to perform a pre-fire extinguishing action. In the event of a fire, the IoT system sends an alert message to the fire department and tells the moving robot to intervene. A fire robot uses a layout algorithm to get to the fireplace, performs firefighting tasks, and transmits the video feed to the fire station to the control center. A firefighting robot cooperates with fire by detecting, extinguishing, and alerting. The robot also connects to the outside world via live video and map view via Bluetooth. The disadvantage of this project is that the robot does not behave intelligently after reaching a certain destination. Incorporating computer vision and machine learning into robot intelligence will help identify the main fireplace. The main objective of this project is to improve the Internet of Things Robots that can take early action in the event of an industrial fire, thus avoiding major damage. Special machine learning and computer vision components, as well as additional sensors, may be added in the future to increase system efficiency. Fire alarm systems will be very helpful in improving the efficiency of the IoRT system.

Sampath, B. Swetha, Fire-fighting robots are used in indoor areas to detect and extinguish fires. Fire sensors are currently used to detect fire in fire extinguishing robots. By using artificial intelligence techniques, fire can be detected over a wide range. Haar Cascade Classifier is a machine learning algorithm originally used for object detection. Transfer learning from a pretrained YOLOv3 model was then used to train the fire detection model to improve accuracy. Haar Cascade Classifier is a machine learning algorithm that can be used to find objects in photos, video and camera server. Learning-based algorithms can also be used to classify images for objects. The camera is positioned low, with a horizontal angle of 90 degrees. The disadvantage of this project is that the robot does not behave intelligently after reaching a certain destination. Incorporating computer vision and machine learning into robot intelligence will help identify the main fireplace. The main objective of this project is to improve the Internet of Things Robots that can take early action in the event of an industrial fire, thus avoiding major damage. To improve system performance, machine learning and computer vision components, as well as additional sensors, may be integrated in the future. Fire learning software techniques will be of great benefit in improving the efficiency of the IoRT system.

Mohd Aliff, M. Yusof, Nor Samsiah Sani, and others. A fire is a catastrophe that can lead to loss of life, destruction of property, and permanent damage to a patient's life. Firefighters are primarily responsible for firefighting, although they are often the most vulnerable. As a result, the study explains the creation of the QRob, a fire-fighting robot capable of extinguishing a fire without putting firefighters in danger. The QRob is also equipped with an ultrasonic sensor to prevent it from colliding with any obstructions or objects nearby, as well as a fire detection sensor. Both sensors are connected to the Arduino Uno, which controls the movement of a DC car. The QRob is set to detect the location of the fire and stand at a height of 40 cm from it. The human user can constantly monitor the robot through a camera connected to a smartphone or other remote device. Due to its compact design, the QRob robot may be rented in areas with small doors or small areas. The user can extinguish fires over a large distance by using a remote control. Users can also monitor ambient parameters throughout the firefighting process using a smartphone camera. According to research results, the robot can detect smoke and fire in just a short time.

Ting L. Chien, H. Guo, et al. Personal health depends on the safety of one's home, laboratory, office, industry, and personal property. For us, we built a smart security system with multiple sensors that included a fire extinguisher robot. The fire engine is made of aluminum frame. The robot has a cylinder shape. The circle is around 50 cm, and the height is about 130 cm. Structure, obstruction and driving system, software development system, fire detection, remote monitoring system, and other systems including a fire engine. The fire detection mechanism for a fire extinguisher combines two fire sensors. Sensors are used in the fire detection system of fire extinguishers and software used in fire detection and combat methods. A low-cost way to identify obstacles. The touch screen is used for personal machine interaction to display system status and standard user interface (GUI). The main controller for a fire extinguisher is an industrial personal computer (IPC). Wireless RF controller, computer monitor, and user using a portable robot. In the future, a barrier detection module using an infrared sensor and an ultrasonic sensor with a novel fusion algorithm can be developed and used for a fire engine. Additionally, a laser distance finder can be integrated to obtain a more accurate and faster location map inside and out.

In today's era fire fighting is an dangerous issue. Many authors are working on different techniques for fire fighting. Author Ratnesh Malik et al. has developed an approach towards fire fighting robot. The robot is designed and constructed which is able to extinguish fire. The robot is fully autonomous. It implements the concept likes environmental sensing and awareness, proportional motor control. The robot processes information from its sensors and hardware elements. Ultraviolet, Infrared and visible light are used to detect the components of environment. The robot is capable of fighting tunnel fire, industry fire and military applications are designed and built. Ultraviolet sensors are used to detect fire. Once fire is detected, robot sounds an alarm. Then the robot activates an electronic valve which release sprinkles of water on the flame. Detailed concept of robot is explained which automatically detects fire and extinguishes it in short time by the use of sensors, microcontroller etc. This robot is used in places where human lives are at high risk.

Author Kristi Kokasih et al. has developed intelligent fire fighting tank robot. Tank robot is made from acrylic, plastic, aluminum and iron. Robot components are two servo motors, two DC motors, ultrasonic sensor, compass sensors, flame detector, thermal array sensor, white detector (IR and photo transistor), sound activation circuit and micro switch sensor. The objective is to search certain area, find and extinguish the flame for different flame positions, room configuration with disturbance. Robot is activated through DTMF transmitter and receiver. Control Of An Autonomous Industrial Fire Fighting Mobile Robot is developed by H.P. Singh et al. The paper describes the construction and design of mobile fire fighting robot. The system contains two optically isolated D.C. motors. Robot performs analog to digital conversion of the data provided by infrared sensors. Five infrared sensor are used. Two sensors control the motion of the robots and three are for flame detection. The extinguisher comprises of D.C water pump and a water container. The basic theme of the paper is to sense the flames of fire and extinguish it. For this infrared sensor is used as input sensor which senses the infrared rays coming out of the fire. The microcontroller controls the extinguishing system.

Wireless fire fighting robot is developed by Swati Deshmukh et al. It comprises of machine which has ability to detect fire and extinguish it. The fire fighting robot can move in both forward and reverse direction and can turned in left and right directions. Thus fire fighter can operate the robot over a long distance and there is no need for human near the area on fire. Light dependent resistors are used for detection of fire. These resistors are highly sensitive devices and are capable of detecting very small fire. The robot provides security at home, buildings, factory and laboratory. It is an intelligent multisensory based security system which contains fire fighting system in daily life.

Cell phone controlled robot with fire detection sensors developed by Lakshay Arora consist of mobile phone which controls a robot by making a call to the mobile phone which is attached to the robot. During the call activation period, if any button is pressed on the phone, the tone corresponding to the button pressed is heard at the other end of the call that is placed on the robot. The robot perceives Dual-Tone Multiple-Frequency (DTMF) tone with the help of phone mounted on the robot.

The received code is processed by the microcontroller and then the robot performs actions accordingly. In the proposed system DTMF technology is used to position the shaft of motor at a required point with different sensors, each performing its own task. Rugged, Simple and cost effective system is proposed here.

Android Phone controlled Robot Using Bluetooth is developed by Arpit Sharma et al. Various techniques of HumanMachine interaction using gestures are presented. Gestures are captured by using the accelerometer. The paper analyses the motion technology to capture gestures using an android smart phone which has inbuilt accelerometer and Bluetooth module to control kinetics of the robot. The microcontroller controls the signals of the Bluetooth module. Features like user friendly interface, lightweight and portability OS based smart phone has overtaken the sophistication of technologies like programmable glove, static cameras etc making them obsolete.

Author SaravananP has designed and developed an Integrated Semi-Autonomous Fire Fighting Mobile robot. The System controls four D.C. motors powered by Atmega2560 and controlled autonomously by navigation system. Navigation system comprises of integrated ultrasonic sensors and infrared sensors. The robot is fitted with wireless camera which captures the video and transmits it to the base station. The fire detection comprises of LDR and temperature sensor. If there is a fire the sensor detects it and the robot will be moved to the source and extinguishes it. The extinguishing system consists of a BLDC motor with water container. The SABOT can be operated manually for extreme conditions. It comprises of a GUI support through which robot can be controlled from the base station.

Intelligent Fire Extinguisher System is developed by Poonam Sonsale et al. The paper proposes of an adaptive fusion algorithm for fire detection. It uses a smoke sensor, flame sensor, temperature sensor for fire detection. It contains intelligent multisensory based security system that contains a fire fighting system in daily life. The security system can detect abnormal and dangerous situation and notify. Intelligent buildings are expected to be safer convenient and efficient living environments for society. The purpose of Intelligent Fire Extinguisher System is to extinguish flame in a certain amount of time. The system detects the fire location and extinguish fire by using sprinklers. As being Intelligent System, it cuts off the electricity of area where fire has been caught and starts the sprinklers only of that area.

Remote Controlled Fire Fighting Robot developed by Phyto Wai Aung describes the functions of remote control fire fighting robot. It contains two main parts that is transmitter and receiver in which two sets of RF modules are used. One RF module is used to transmit the data to the motor driver and another RF module is used to know the condition on fire. Microcontroller PIC16F887 is used operate the whole system of the fire fighting robot. The motors are driven by the L298 and ULN2003 drivers in this system. The operator controls the robot by using wireless camera mounted on the robot. If the temperature of fire sight is above 40 degree Celsius, the alarm will be ringing so that operator can control the fire fighting robot and avoid the damage of heat.

The feasibility of fire-fighting robot to deal with such troublesome situations past the scope of human has been proposed in different papers. In this paper we have dedicated our effort in designing a manually controlled fire extinguishing robot because autonomous fire-fighting robots proposed in earlier papers do not produce more efficient results than those which can be manually controlled by users. Some of the robots that are proposed takes usually a longer time in processing and scanning the environment for presence of fire, their incapability to extinguish vulnerable affected areas first may lead the fire to spread wildly leading to loss of life and property causing mass destruction. In some cases the robots are operated in a given restricted environment and so there exhibit a constraint in their application in real time environment. Totally depending upon the readings of the sensors in a fire hazard environment may prove to be inappropriate as faulty reading of sensors due to disruptive condition of the environment may cause the robot to be totally ineffective. Moreover streaming videos over cloud may produce undesirable latency in real time application and hence is seldom used. Hence our robot was designed keeping in mind all this factors to overcome such inefficiencies. The process of scanning the environment for the presence of fire usually takes a longer time and is overcome by giving the entire authority to the user to make the robot move in areas the user desires so that vulnerable areas are handled first, along with different sensors a webcam is also mounted on top of the robot so that even if the sensors provide faulty readings the user can still be sure of the situation and the surrounding the robot is under and vice versa. Robots which are controlled wirelessly using raspberry pi via Wi-Fi dongle from remote location solely depends upon distance of the robot and raspberry pi and with the increase in distance their operational delay seems to increase which may lead to havoc in fire-fighting scenario when being operated from remote location and so a Weaved IOT platform is chosen which only relies upon a good internet connection so that user can actively interact with the robot with least delay irrespective of the distance between robot and the user. Weaved provides an IoT platform allowing the robot to be accessed by the user from remote location over different network by enabling Port Forwarding automatically which may otherwise prove to be a difficult task if done manually.



My research describes the design of a small autonomous Fire Fighting Robot. I have worked on the same project at my college presenting a synopsis showing its basic construction and working. The Fire Fighting Robot is designed to search for a fire in a small floor plan of a house of the specific dimensions, extinguish the fire with the help of a toy hovercraft, and then return to the front of the house. This mission is divided into smaller tasks, and each task is implemented in the most efficient manner such as self-autonomous start of the robot, navigation of the robot in every room step by step, finds the fire in a specific room, approaches the fire at a very fixed distance, and extinguishes it and finally returning to the front of the house. Finding the target or fire is achieved by the remote control. The very important and crucial concept of this Fire Fighting Robot is that it navigates and extinguishes the candle by colliding with the wall of the floor plan to at least extent. Along with these crucial tasks were other design constraints, such as the size, speed, and supply of power. The size of the robot should be small enough so that it could perform its task quickly and efficiently. The speed should be fast enough to perform the task on time. The supply of power should be enough to do the extinguishing process and economically feasible as well making the whole vehicle light and comfortable. Each defining characteristic of the robot is described in more detail here. One of the major hazards associated with fire fighting operations is the toxic environment created by combusting materials. The four major hazards associated with these situations are smoke, the oxygen deficient atmosphere, elevated temperatures, and toxic atmospheres. Additional risks of fire include falls and structural collapse.

Home could furnish safety, convenience, and productivity for men in the 21st century. Several functions, frameworks and systems are used to integrate an intelligent home system. A stand out amongst the practically significant frameworks may be the fire identification work framework in a smart home system. In the previous literatures, huge numbers masters Look into in the administration robot. Exactly Look into tended to done Creating target-tracking framework for administration robot, for example, Hisato Kobayashi et al. Recommended a strategy on identify individual towards a self-sufficient versatile watch robot [6]. Moreover, exactly scrutinized ended to in the robot need the ability about fire-fighting. Ruser, further more Magori depicted those fire identification with a consolidation for ultrasonic also microwave doppler sensor. Ruser, H. Furthermore Magori, V, "Fire identification with joined together ultrasonic microwave doppler sensor," in incidents from claiming IEEE ultrasonic Symposium, Vol. 1, 1998, pp. 489-492. Luo also Su use two smoke sensors, two temperature sensors and two fire sensors to identify fired affected area, and finding which sensor will be disappointed utilizing versatile combination strategy.

The fire extinguisher systems available today, need humans to operate them. These systems lack intelligence. Also, even if the fire is small and limited to a small area, the CO<sub>2</sub> is sprayed on a larger area which causes wastage. Further, these fire systems cannot protect, the humans operating the system, from fire. Thus, this becomes the major point of concern.

To avoid this, technology has stepped forward and created a fire extinguishing system. This system is nothing but a robot that extinguishes the fire, according to the operator's command, considering that the robot is being operated from a remote area.

The main purpose of developing the proposed Voice Controlled Fire Extinguisher Vehicle is to allow the user to control the fire extinguishing robotic vehicle through a wireless communication. For this to work efficiently, a voice recognition module VR3.1 [4] has been used. Out of all the speech recognition systems [5][6] studied so far, the VR3.1 seems the best. The characteristics of this module seem better than the modules used earlier. The proposed system improves the capabilities of method of extinguishing fire from remote area. The direction of the Robotic vehicle can be controlled by the voice commands from the user, based on the view of the situation, available on the screen. The proposed vehicle is having the facility of CO<sub>2</sub> spray. Based on user's voice commands, the cylinder can be moved in any direction.

The transceiver module on the robotic vehicle receives the command which will be fed to the processor. This controls motors, sensors, cylinder, and the camera module of vehicle. The live videos of the situation can be captured by the camera mounted on the vehicle. The user part receives the live videos from the camera and displays it on to the screen.

### III. DESIGN OF FIRE FIGHTING ROBOT

#### A. Arduino UNO

The Arduino UNO is a standard board of Arduino. Here UNO means 'one' in Italian. It was named as UNO to label the first release of Arduino Software. It was also the first USB board released by Arduino. It is considered as the powerful board used in various projects. Arduino.cc developed the Arduino UNO board.

Arduino UNO is based on an ATmega328P microcontroller. It is easy to use compared to other boards, such as the Arduino Mega board, etc. The board consists of digital and analog Input/Output pins (I/O), shields, and other circuits.

The Arduino UNO includes 6 analog pin inputs, 14 digital pins, a USB connector, a power jack, and an ICSP (In-Circuit Serial Programming) header. It is programmed based on IDE, which stands for Integrated Development Environment. It can run on both online and offline platforms.

The IDE is common to all available boards of Arduino. The components of Arduino UNO are :-

- ATmega328 Microcontroller - It is a single chip Microcontroller of the ATmel family. The processor code inside it is of 8-bit. It combines Memory (SRAM, EEPROM, and Flash), Analog to Digital Converter, SPI serial ports, I/O lines, registers, timer, external and internal interrupts, and oscillator.
- ICSP pin - The In-Circuit Serial Programming pin allows the user to program using the firmware of the Arduino board.
- Power LED Indicator - The ON status of LED shows the power is activated. When the power is OFF, the LED will not light up.
- Digital I/O pins - The digital pins have the value HIGH or LOW. The pins numbered from D0 to D13 are digital pins.
- TX and RX LED's - The successful flow of data is represented by the lighting of these LED's.
- AREF - The Analog Reference (AREF) pin is used to feed a reference voltage to the Arduino UNO board from the external power supply.
- Reset button - It is used to add a Reset button to the connection.
- USB - It allows the board to connect to the computer. It is essential for the programming of the Arduino UNO board.
- Crystal Oscillator - The Crystal oscillator has a frequency of 16MHz, which makes the Arduino UNO a powerful board.
- Voltage Regulator - The voltage regulator converts the input voltage to 5V.
- GND - Ground pins. The ground pin acts as a pin with zero voltage.
- Vin - It is the input voltage.
- Analog Pins - The pins numbered from A0 to A5 are analog pins. The function of Analog pins is to read the analog sensor used in the connection. It can also act as GPIO (General Purpose Input Output) pins.

The USB port in the Arduino board is used to connect the board to the computer using the USB cable. The cable acts as a serial port and as the power supply to interface the board. Such dual functioning makes it unique to recommend and easy to use for beginners.

The technical specifications of the Arduino UNO are listed below :-

There are 20 Input/Output pins present on the Arduino UNO board. These 20 pins include 6 PWM pins, 6 analog pins, and 8 digital I/O pins.

The PWM pins are Pulse Width Modulation capable pins.

The crystal oscillator present in Arduino UNO comes with a frequency of 16MHz.

It also has a Arduino integrated WiFi module. Such Arduino UNO board is based on the Integrated WiFi ESP8266 Module and ATmega328P microcontroller.

The input voltage of the UNO board varies from 7V to 20V.

Arduino UNO automatically draws power from the external power supply. It can also draw power from the USB.

We can program the Arduino UNO using the Arduino IDE. The Arduino IDE is the Integral Development program, which is common to all the boards.

We can also use Arduino Web Editor, which allows us to upload sketches and write the code from our web browser (Google Chrome recommended) to any Arduino Board. It is an online platform.

The USB connection is essential to connect the computer with the board. After the connection, the PWR pins will light in green. It is a green power LED.



Fig. 1: Arduino UNO

### B. Motor Driver L293D

The L293 and L293D devices are quadruple high current half-H drivers. The L293 is designed to provide bidirectional drive currents of up to 1 A at voltages from 4.5 V to 36 V. The L293D is designed to provide bidirectional drive currents of up to 600-mA at voltages from 4.5 V to 36 V. Both devices are designed to drive inductive loads such as relays, solenoids, DC and bipolar stepping motors, as well as other high current / high voltage loads in positive supply applications.

Each output is a complete totem-pole drive circuit, with a Darlington transistor sink and a pseudo- Darlington source. Drivers are enabled in pairs, with drivers 1 and 2 enabled by 1,2EN and drivers 3 and 4 enabled by 3,4EN. L293 and L293D are characterized for operation from 0°C to 70°C.

Other important L293D features are :-

Wide Supply-Voltage Range: 4.5 V to 36 V

Separate Input-Logic Supply

Internal ESD Protection

High-Noise-Immunity Inputs

Output Current 1 A Per Channel (600 mA for L293D)

Peak Output Current 2 A Per Channel (1.2 A for L293D)

Output Clamp Diodes for Inductive Transient Suppression (L293D)

An H bridge is an electronic circuit that enables a voltage to be applied across a load in opposite direction. These circuits are often used in robotics and other applications to allow DC motors to run forwards or backward.

The term H bridge is derived from the typical graphical representation of such a circuit. An H bridge is built with four switches (solid-state or mechanical). When the switches S1 and S4 are closed (and S2 and S3 are open) a positive voltage will be applied across the motor. By opening S1 and S4 switches and closing S2 and S3 switches, this voltage is reversed, allowing reverse operation of the motor.

Using the nomenclature above, the switches S1 and S2 should never be closed at the same time, as this would cause a short circuit on the input voltage source. The same applies to the switches S3 and S4. This condition is known as shoot-through.

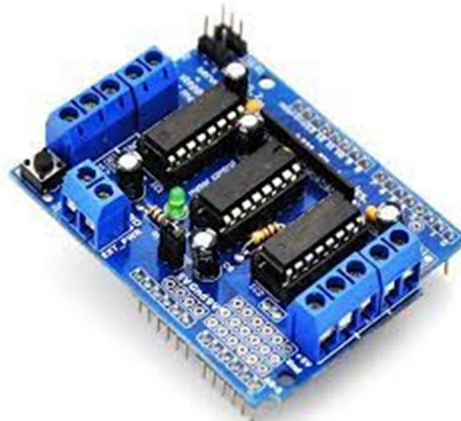

Fig. 2: L293D Motor Driver

### C. Gear Motor

A gear motor is an electric motor and a power reducer combined into a single unit that reduces the number of revolutions but increases the torque of the operating shaft. Such gears for electric motors are often used in modern machines and mechanisms, it is universal for many types of equipment. Some hybrid models combine practicality and durability. The housing is made of plastic and the gears are made of metal. This design gives a minimum noise level during the operation of the devices, the voltage can be from 12 to 24 V.

A hybrid gear motor is considered the best option when it comes, for example, to household appliances. Without it, a cordless mixer, a portable music speaker, an electric toothbrush or electric razor, a car vacuum cleaner, and much more would not work. Even the device that automatically opens curtains or raises blinds has a gear motor.

Every year the scope of such devices is expanding, new models are replacing outdated ones, and the mechanisms are made of plastic instead of metal gears lubricated by special oil. In some aspects, the new manufacturing format makes the device less durable, but the reducer thus acquires new qualities - compactness and low weight. There are some designs in which the use of a plastic geared motor is unacceptable due to the increased load, but there are so-called hybrids, which are made of metal and plastic.

This type of manufacturing has proven to be a reliable and trouble-free assembly because the housing is made of durable plastic and the gears are made of metal. In some models, the first stage gears are also made of plastic, since the loads on the first stage gearbox of low-power motors are not so great. This allows for some compromise in the practicality and durability of geared motors.

Domestic appliances use this type of gear motor because they make as little noise as possible during operation, which is very good for use in the home. You can find them in cordless kitchen mixers, some electric shavers, and other devices. The most common voltage used in these gear motors is 12V or more depending on the type of motor and the end device.

The gear motor is designed as a mechanical gear unit combined with an electric motor. This makes it possible to have one installation site instead of two in a processing plant. Also, you will not have to ensure the tolerance of the motor and gearbox shafts, to select and mount the coupling that transmits the rotation. The overall design of the gear motor has some differences from the split versions. The gear housing is made with the necessary safety margin to ensure the reliable operation of the device with a heavy motor attached.

For mounting the motor on the housing, special slots are provided. The gear motor drive pinion has cylindrical holes for mounting the drive motor shaft. The housing is additionally provided with mounting elements for installing the gear motor in the processing unit. Any type of electric motor can be used as the electric drive of the gear motor. The most common models use standard asynchronous motors. For the realization of the monoblock design, flange-type models are chosen.

The principle of gear motor working does not differ from the operation of a classic electric gear drive. The motor torque is transmitted to the drive pinion, which is mounted on the motor shaft. Thanks to the gearing, the torque is converted by one or more driven elements, which in turn act on the shaft of the technological mechanism.

The output rotation speed depends on the motor parameters and the gear ratio. Multistage models are used to obtain a higher conversion ratio. When speed corrections are required, geared motors can easily be integrated into speed-controlled systems via controlled converters.

The general principle of a DC gear motor is that the first part of it converts some energy into mechanical energy, and the second element is already designed to transfer the available mechanical energy to the output shaft to change its speed.



Fig. 3: Gear Motor

#### D. Fire Sensor

It is a crucial sensor module for deployment in flame alarm systems in buildings. A flame sensor detects a flame within the wavelength of 760nm – 1100 nm from a specific light source. While effective as detection equipment, it can easily get damages when subjected to high temperatures. Because of this, always place it at a specific distance from the flame source.

A flame sensor's typical flame detection distance is 100cm with a detection angle of 60°. A flame sensor can have a digital or analog signal. It thus forms a crucial element in fire or flame fighting robots such as alarms (flame alarms).

A flame sensor comes as a special detector designed for sensing besides responding to flame or fire incidences. In most instances, the detection response to the flame depends on its fittings. For instance, it can include propane, natural gas line, alarm system, and a fire or flame suppression system. In addition, industrial applications like boiler systems provide authentication of whether it (boiler) works properly or not.

The response timeline of flame sensors proves more rapid and accurate than smoke/heat detectors due to its detection mechanism. The working principle of a flame sensor proves straightforward to anyone familiar with sensors. One has to develop it with an electronic circuit that uses a receiver such as electromagnetic radiation. Almost all of the flame sensors I know use an infrared flame flash approach, which allows the sensor to function without any coating of water vapor, dust, oil, or otherwise ice.

A flame sensor has a configuration that entails four pins, especially when it is working with a microcontroller unit such as an Arduino. The pins encompass the following :-

Pin1 comes as the VCC pin. It has a supply voltage of 3.3V to 5.3V.

Pin2 come as a GND, which is the ground pin.

Pin3 is the AOUT. It is the analog output pin commonly known as MCU.IO.

Pin4 comes as the DOUT. It is a digital output pin that we commonly call MCU.IO as well.



Fig. 4: Fire Sensor

#### E. 5V DC Submersible Pump

A submersible pump (or sub pump, electric submersible pump (ESP)) is a device which has a hermetically sealed motor close-coupled to the pump body. The whole assembly is submerged in the fluid to be pumped. The main advantage of this type of pump is that it prevents pump cavitation, a problem associated with a high elevation difference between the pump and the fluid surface. Submersible pumps push fluid to the surface, rather than jet pumps, which create a vacuum and rely upon atmospheric pressure. Submersibles use pressurized fluid from the surface to drive a hydraulic motor downhole, rather than an electric motor, and are used in heavy oil applications with heated water as the motive fluid.

Electric submersible pumps are multistage centrifugal pumps operating in a vertical position. Liquids, accelerated by the impeller, lose their kinetic energy in the diffuser, where a conversion of kinetic to pressure energy takes place. This is the main operational mechanism of radial and mixed flow pumps. In the HSP, the motor is a hydraulic motor rather than an electrical motor, and may be closed cycle (keeping the power fluid separate from the produced fluid) or open cycle (mingling the power fluid with the produced fluid downhole, with surface separation).

The pump shaft is connected to the gas separator or the protector by a mechanical coupling at the bottom of the pump. Fluids enter the pump through an intake screen and are lifted by the pump stages. Other parts include the radial bearings (bushings) distributed along the length of the shaft, providing radial support to the pump shaft. An optional thrust bearing takes up part of the axial forces arising in the pump, but most of those forces are absorbed by the protector's thrust bearing.

There are also screw-type submersible pumps, there is a steel screw which is used as a working element in them. The screw allows the pump to work in water with a high sand content and other mechanical impurities.

Submersible pumps are found in many applications. Single stage pumps are used for drainage, sewage pumping, general industrial pumping and slurry pumping. They are also popular with Pond filters. Multiple stage submersible pumps are typically lowered down a borehole, and most typically used for residential, commercial, municipal and industrial water extraction (abstraction), water wells and in oil wells.

Other uses for submersible pumps include sewage treatment plants, seawater handling, fire fighting (since it is flame retardant cable), water well and deep well drilling, offshore drilling rigs, artificial lifts, mine dewatering, and irrigation systems.

Pumps in electrical hazardous locations used for combustible liquids or for water that may be contaminated with combustible liquids must be designed not to ignite the liquid or vapors.

A submersible pump cable is a specialized product to be used for a submersible pump in a deep well, or in similarly harsh conditions. The cable needed for this type of application must be durable and reliable, as the installation location and environment can be extremely restrictive as well as hostile. As such, submersible pump cable can be used in both fresh and salt water. It is also suitable for direct burial and within well castings. A submersible pump cable's area of installation is physically restrictive. Cable manufacturers must keep these factors in mind to achieve the highest possible degree of reliability. The size and shape of submersible pump cable can vary depending on the usage and preference and pumping instrument of the installer. Pump cables are made in single and multiple conductor types and may be flat or round in cross section; some types include control wires as well as power conductors for the pump motor. Conductors are often color-coded for identification and an overall cable jacket may also be color-coded.



Fig. 5: 5V DC Submersible Pump

#### IV. EXPERIMENTAL VALIDATION

We have used a steel plate for the base of the robot. We have also calculated its dimensions in below fig.

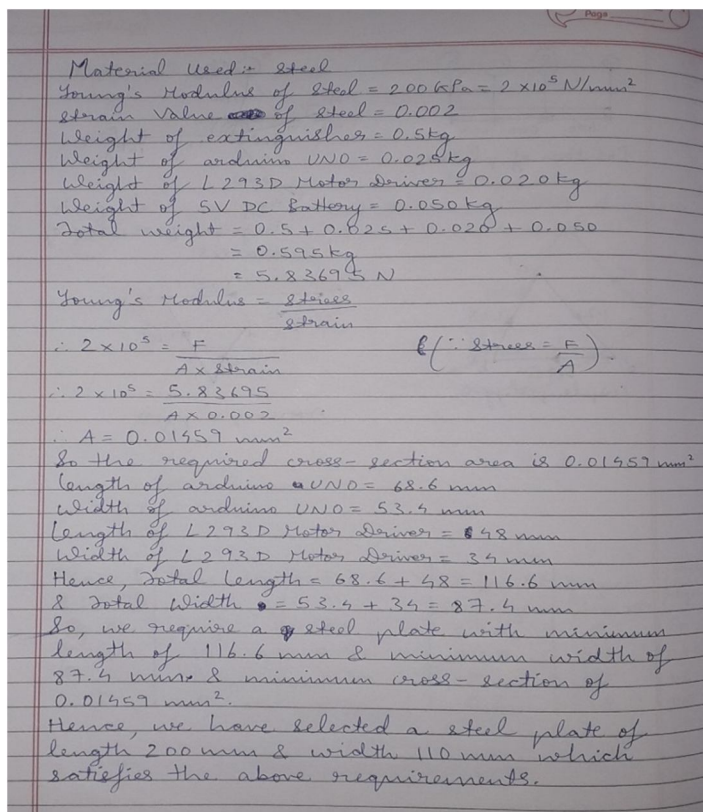

Fig. 6: Calculations for Robot

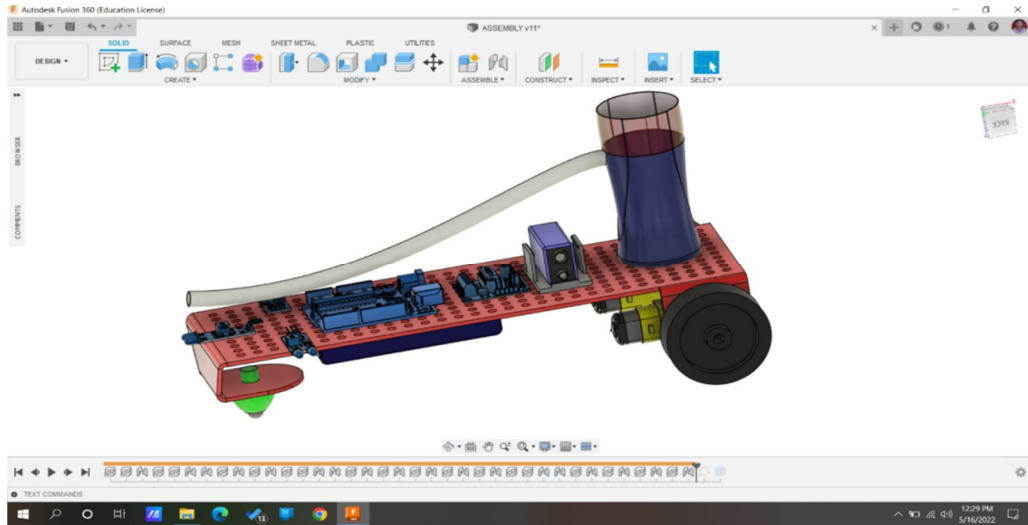

Fig. 7: Model of Fire Fighting Robot

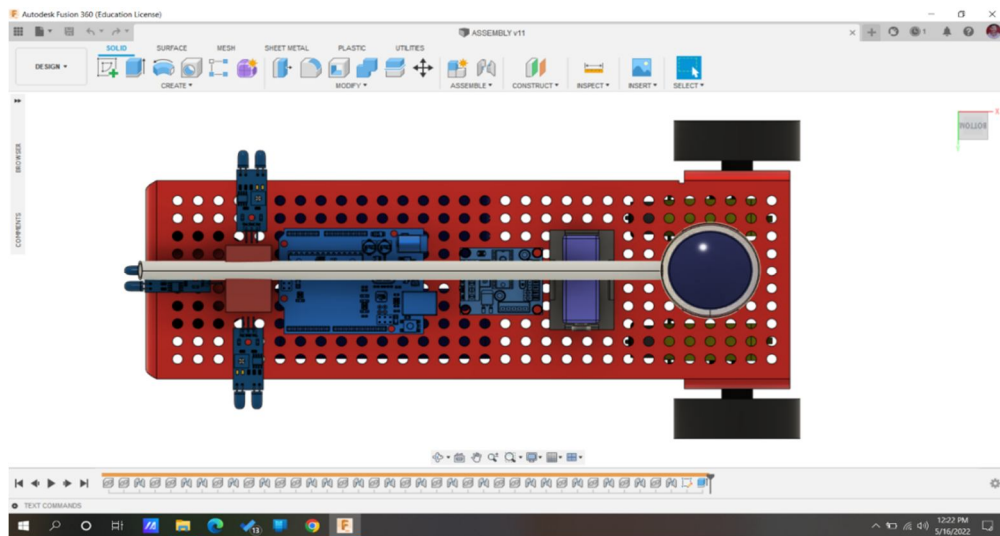

Fig. 8: Top View of Model

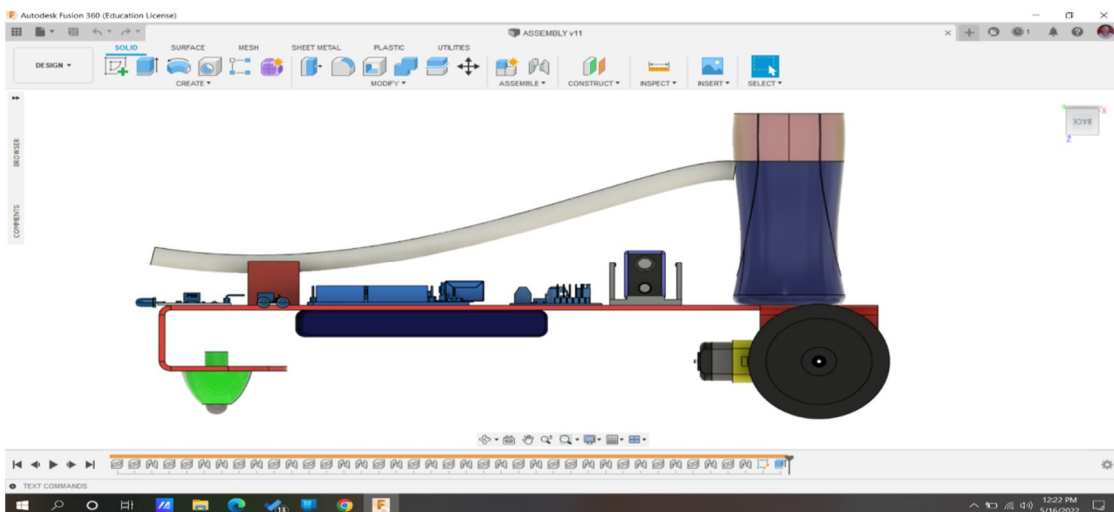

Fig. 9: Side View of Model

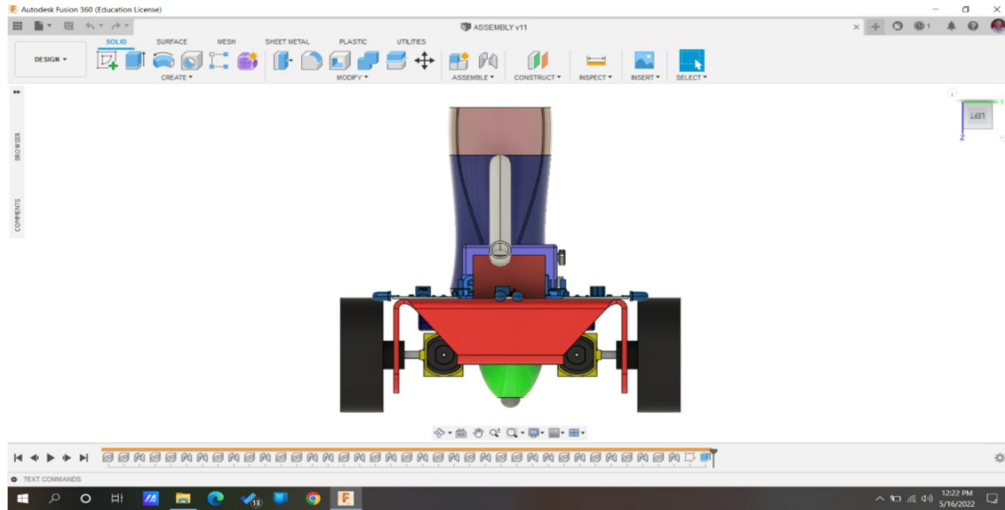

Fig. 10: Front View of Model

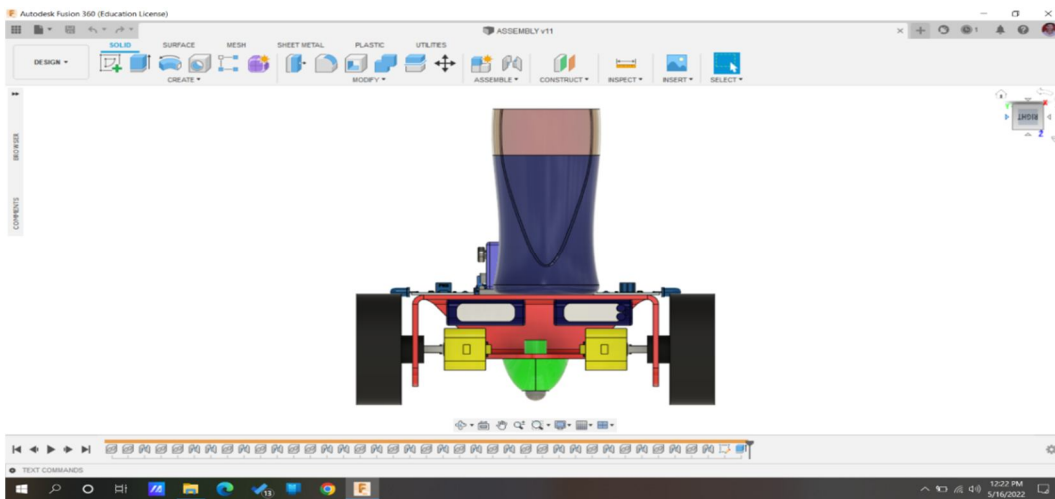

Fig. 11: Back View of Model

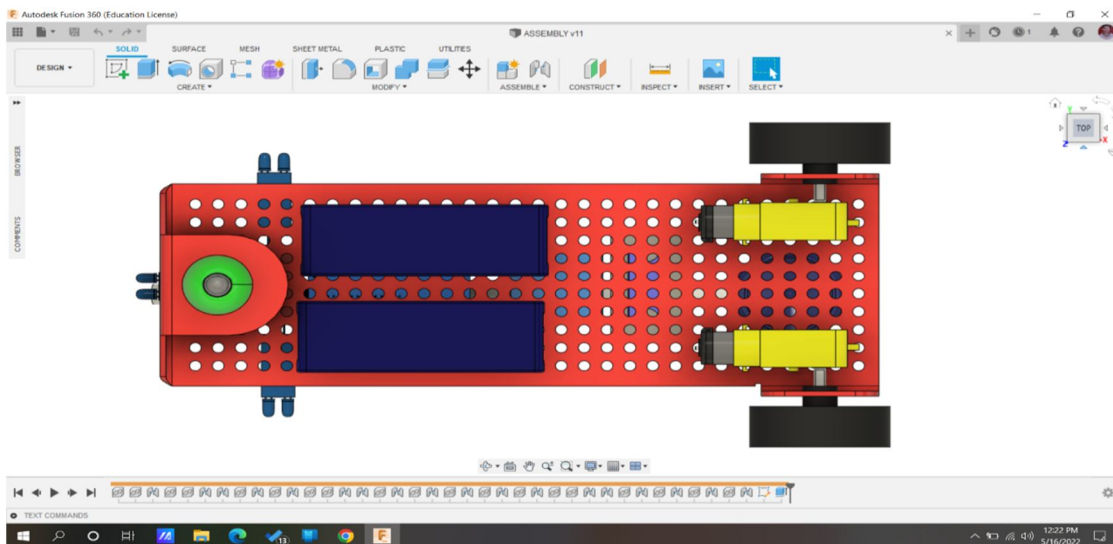

Fig. 12: Bottom View of Model



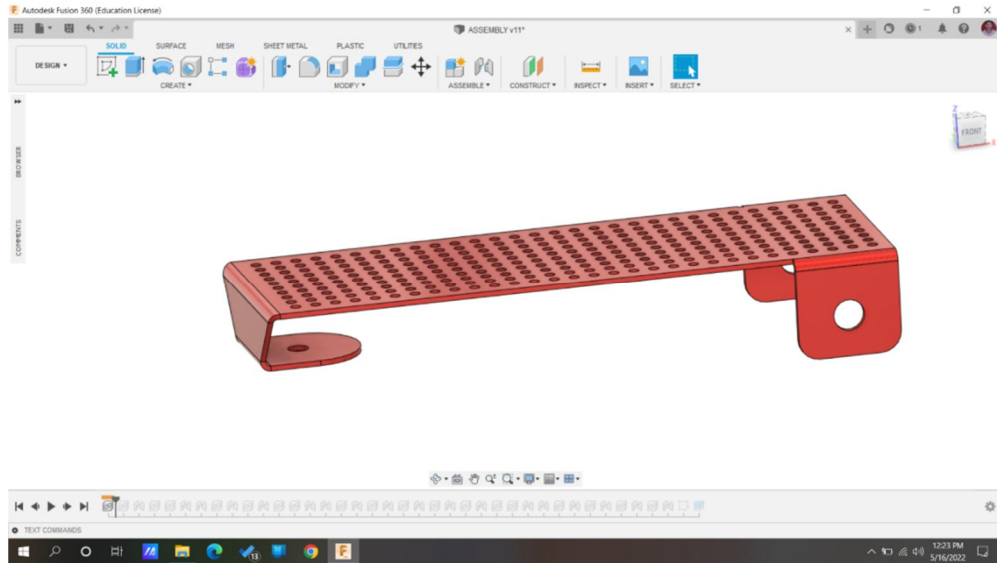

Fig. 13

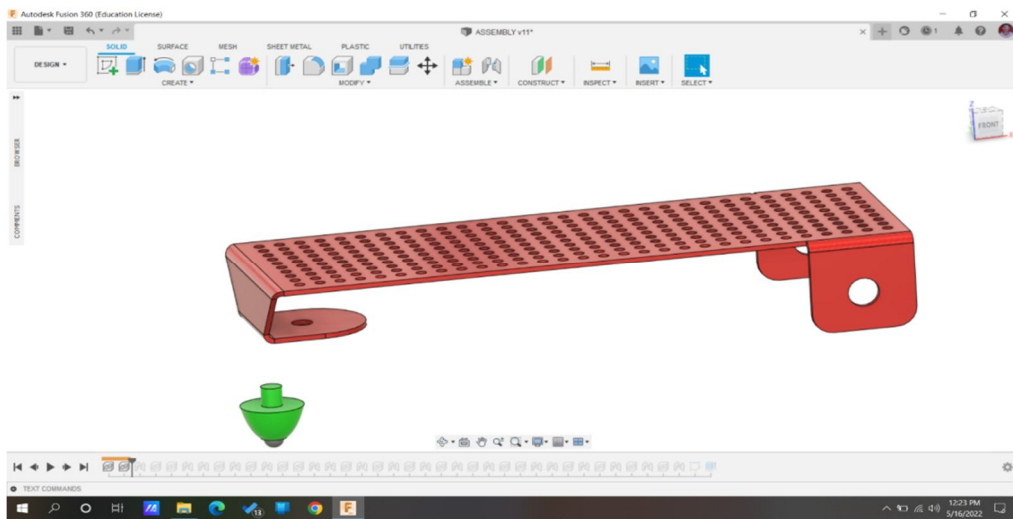

Fig. 14

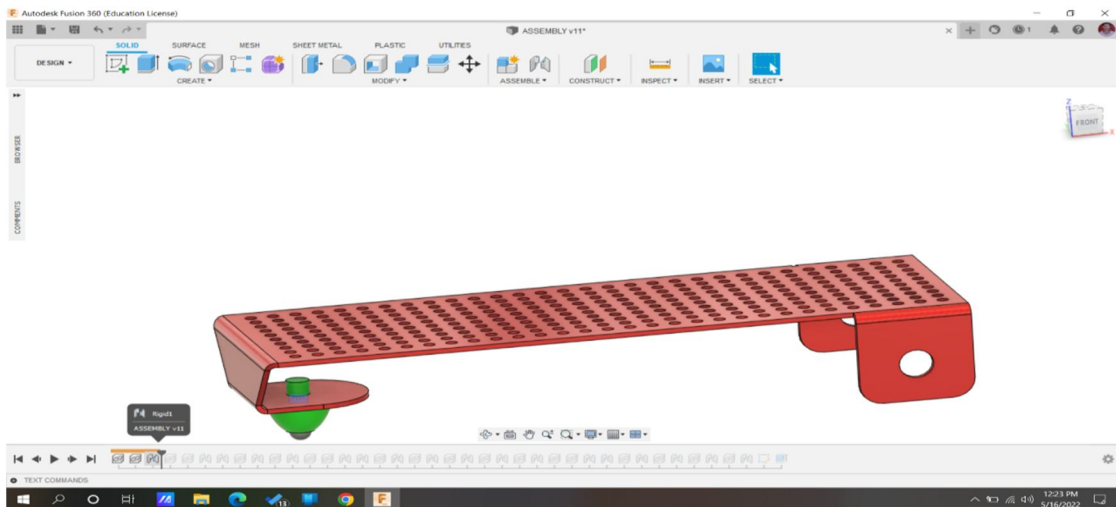

Fig. 15

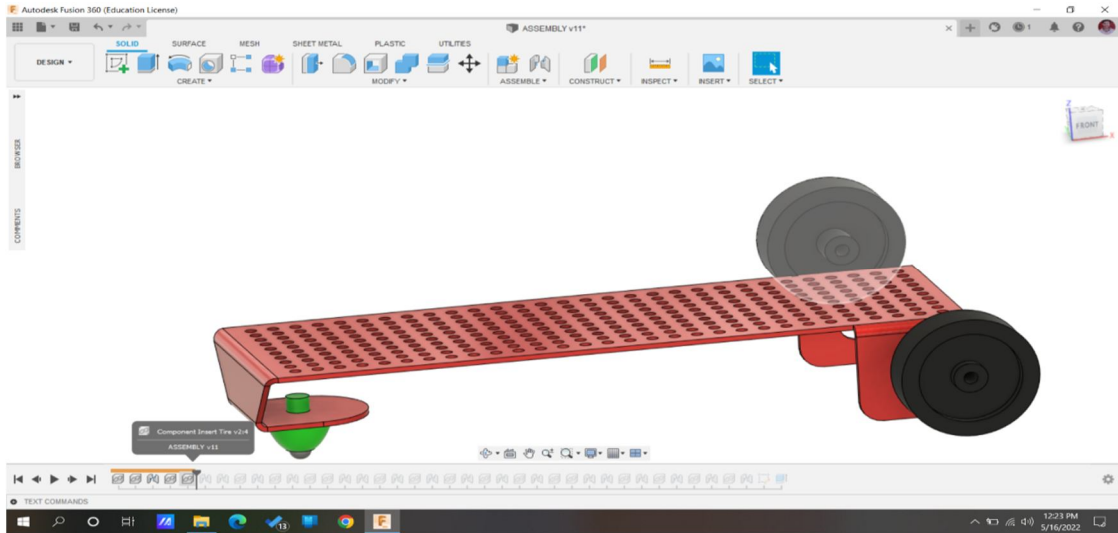

Fig. 16

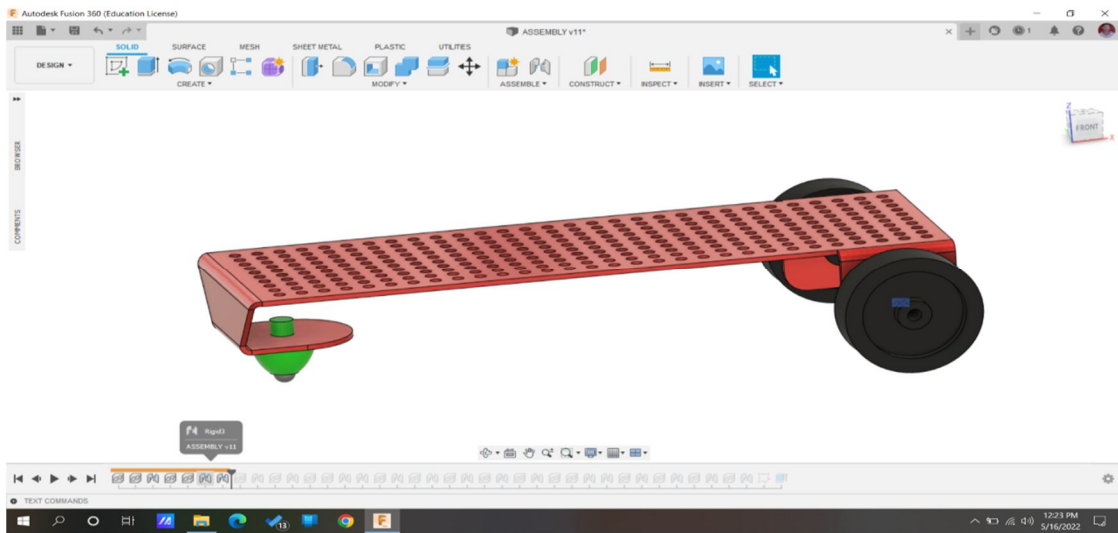

Fig. 17

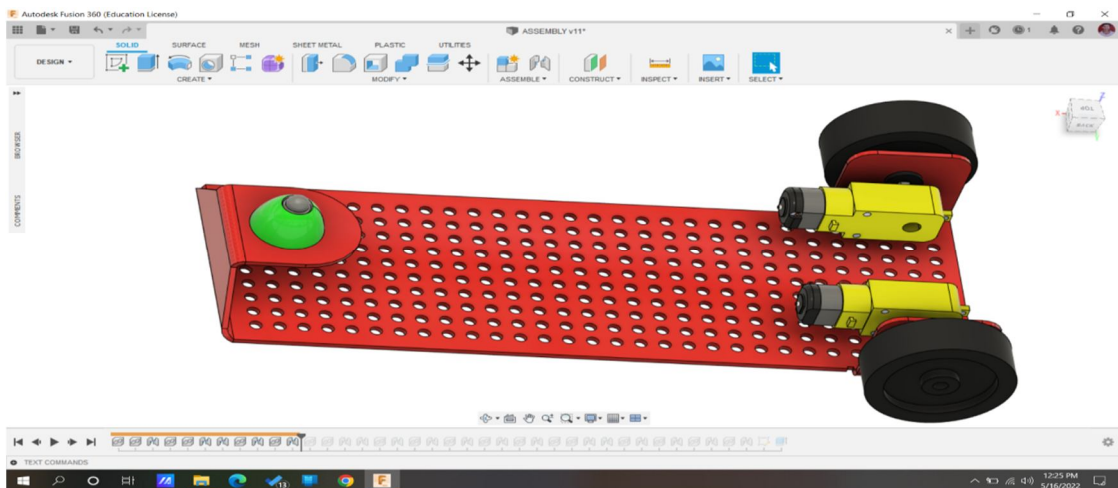

Fig. 18

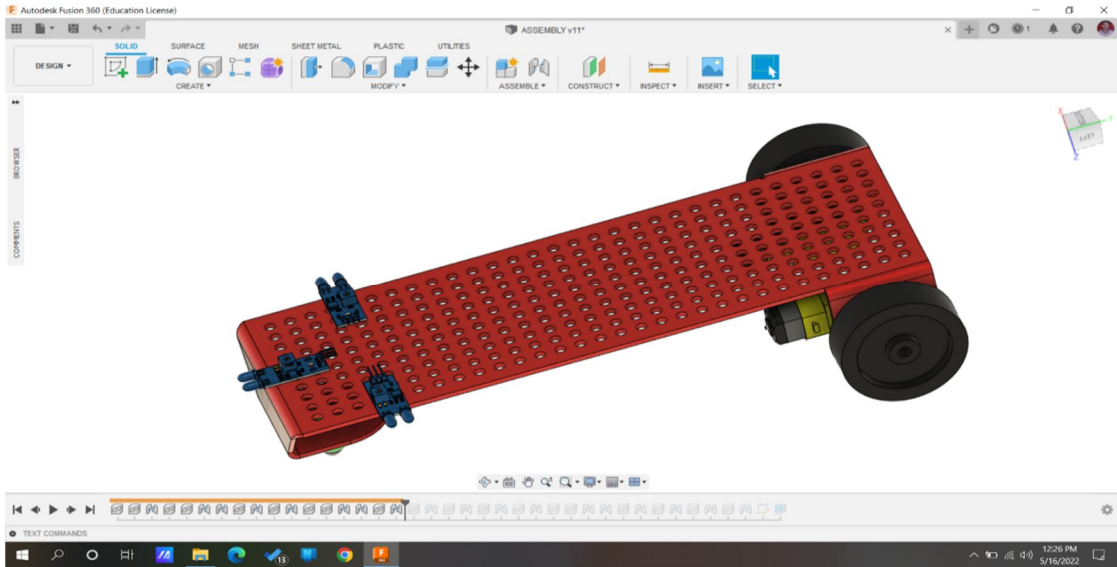

Fig. 19

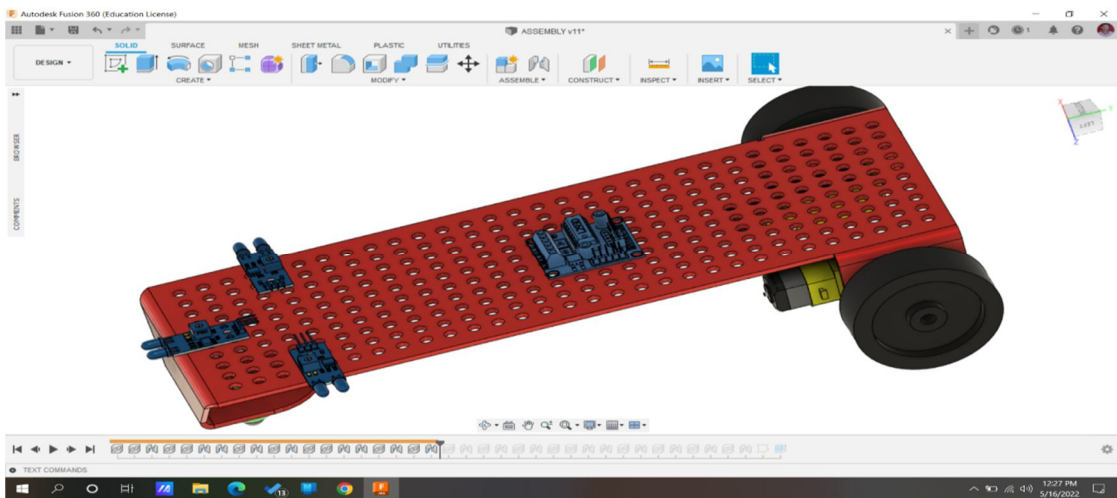

Fig. 20

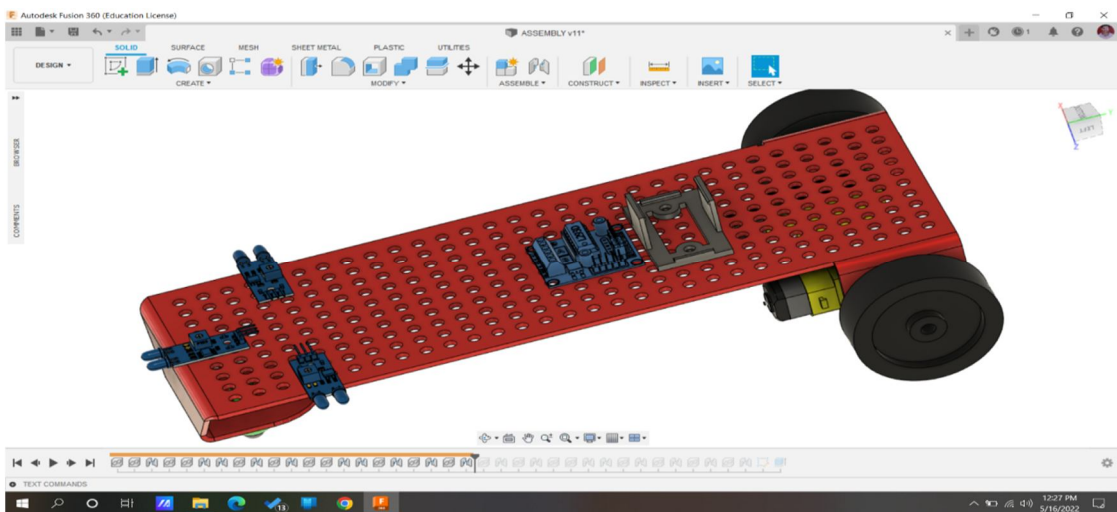

Fig. 21

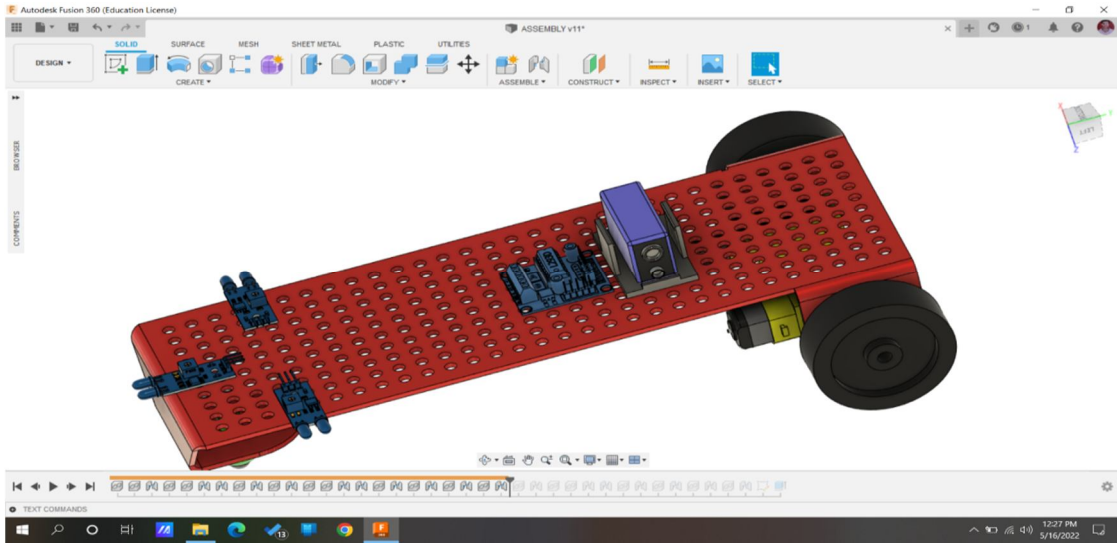

Fig. 22

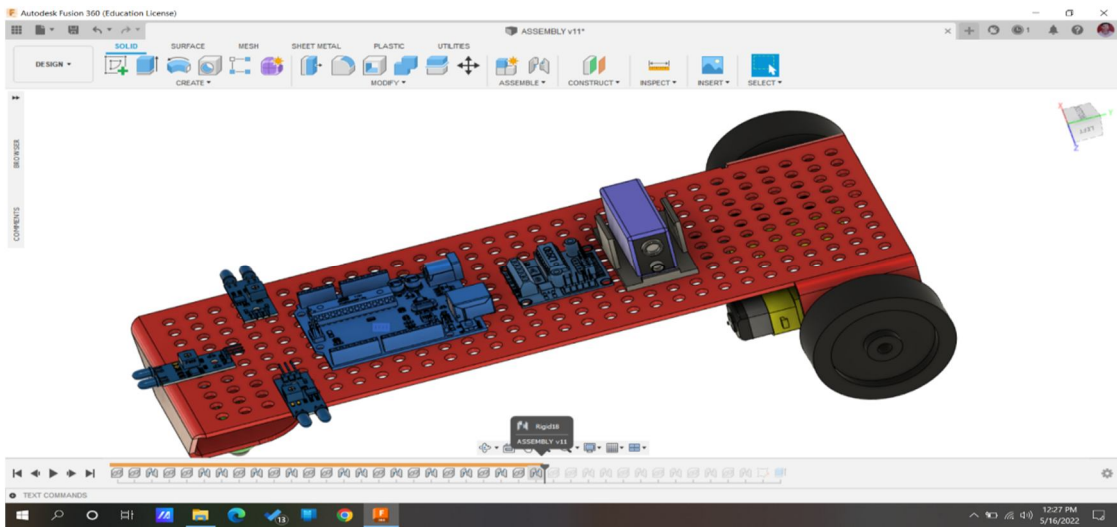

Fig. 23

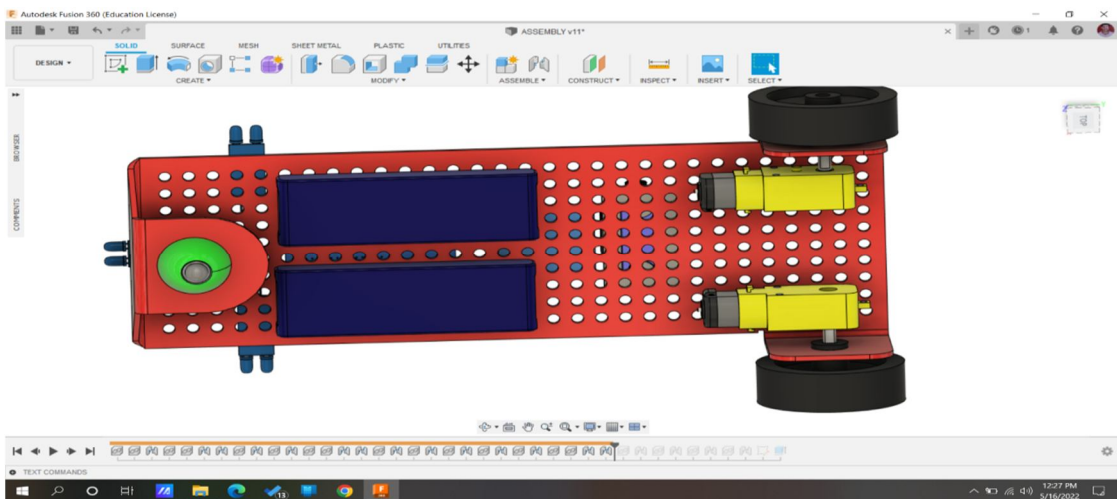

Fig. 24

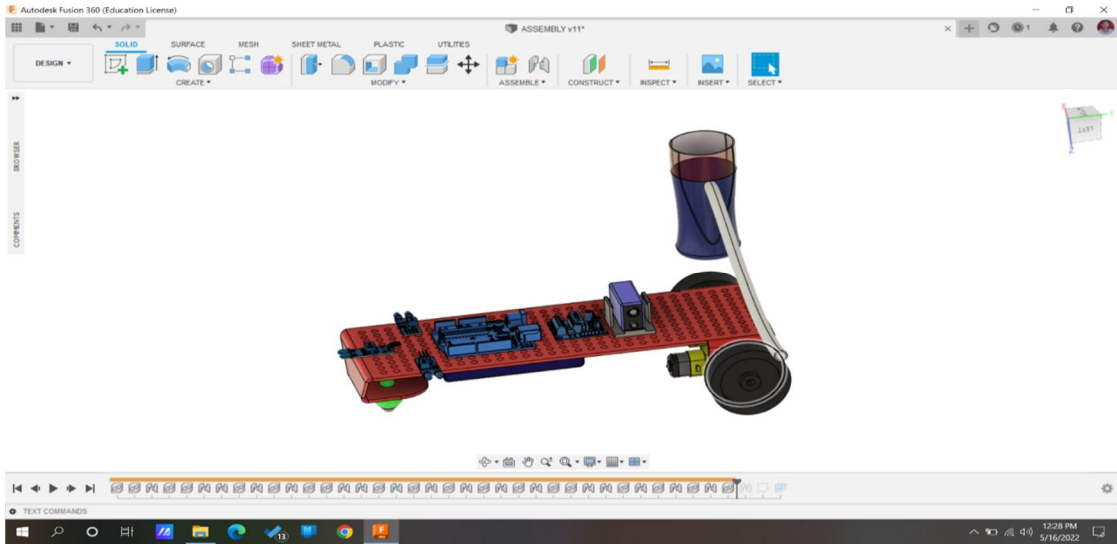

Fig. 25

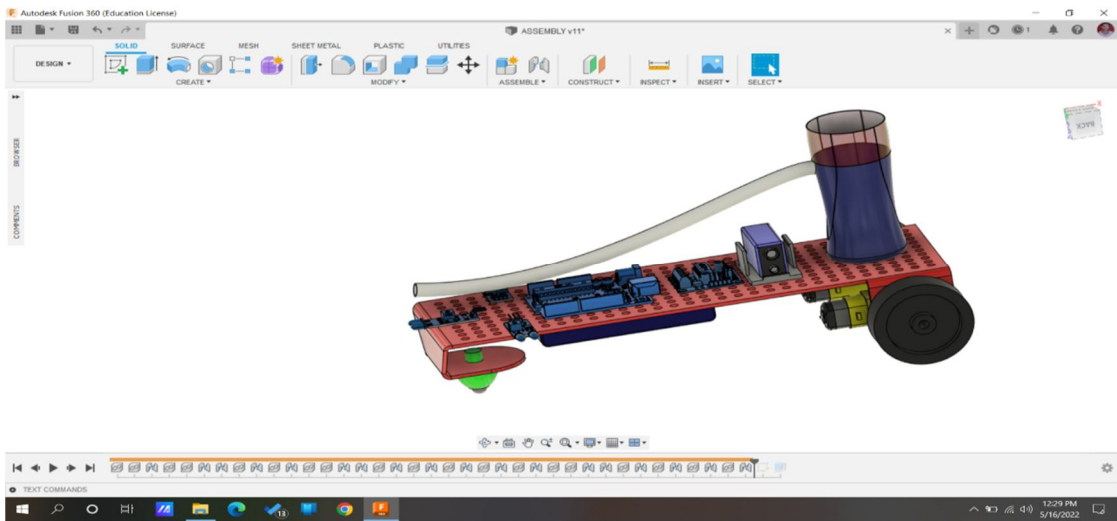

Fig. 26

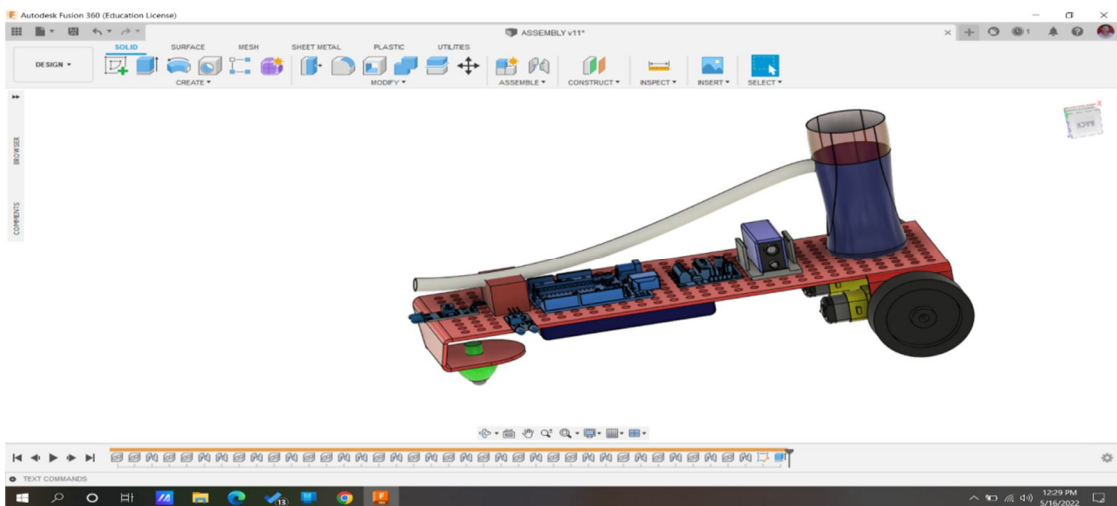

Fig. 27

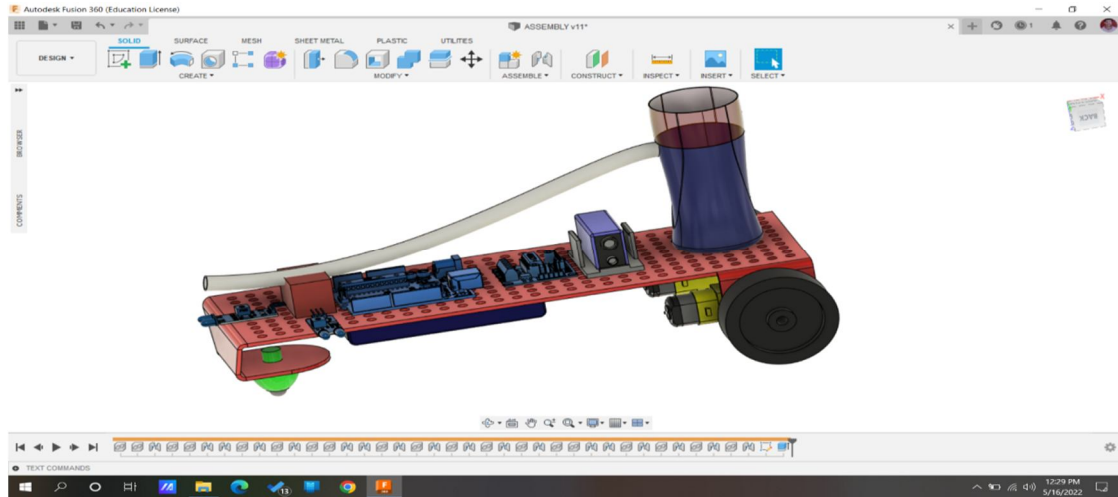

Fig. 28

## V. CONCLUSION AND FUTURE SCOPE

The circuit of our project was designed and setup using Arduino uno which is very reliable & stable. In the fire extinguishing robot project, we developed a system that detects and extinguishes the fire before the fire starts and informs the electronic environment. Here targets are microcontroller and motor control with reductive motor, flame detection with fire sensor. The robot which is designed here as a result of this study communicates through the serial port via the serial port and processes the analog and digital data received from the sensors in the microcontroller control so as to determine the fire in the open or close environment. In this work, a system that works successfully both hardware and software has been realized. This system "fire detection and extinguishing robot" is capable of being used in our everyday life, if more professionals are selected instead of the elements used in the project, which can be added to the robot, the fire can be firstly intervened and most of the fire can be extinguished without any growth. For future scope, camera and video transmission can be added in our future prospect with the robotic vehicle and the weight capacity of the robotic vehicle can be improved.

Through this we can conclude that a robot can be used in place of humans reducing the risk of life of the fire fighters. We can use them in our homes, labs, offices etc. They provide us greater efficiency to detect the flame and it can be extinguish before it become uncontrollable and threat to life. Hence, this robot can play a crucial role. Fire fighting robot can be easily and conveniently used. Operate automatically when any fire occurs. Robot comprises of very small size, less in weight, hence require less space. Rechargeable batteries are used here. Rechargeable batteries produce less waste because they can be recharged with a simple battery charger and reused hundreds of times. Each task is implemented in the most efficient manner such as selfautonomous start of the robot, navigation of the robot in every room step by step, finds the fire in a specific room, approaches the fire at a very fixed distance, and extinguishes it and finally returning to the front of the house. Finding the target or fire is achieved by the remote control. The very important and crucial concept of this Fire Fighting Robot is that it navigates and extinguishes the candle by colliding with the wall of the floor plan to at least extent. Along with these crucial tasks were other designs constraints, such as the size, speed, and supply of power and it can through 10-15 feet water.

## REFERENCES

- [1] Aliff, M., S. Dohta, and T. Akagi, Simple Trajectory Control Method of Robot Arm Using Flexible Pneumatic Cylinders. *Journal of Robotics and Mechatronics*, 2015. 27(6): p. 698-705
- [2] H. Hyung, B. Ahn, B. Cruz and D. Lee, Analysis of android robot lip-sync factors affecting communication, 11th ACM/IEEE International Conference on Human-Robot Interaction (HRI), 2016, pp. 441-442
- [3] Bradshaw, 1991 "The UK Security and Fire Fighting Advanced Robot Project," IEE colloquium on advanced robotic initiatives in the UK, pp.1/1-1/4
- [4] T. Aprille and T. Trick., "Steady-state analysis of nonlinear circuits with periodic inputs", *Proceedings of the IEEE*, vol. 60, no. 1, pp. 108-114, January 1972.
- [5] Preeti Dhiman, Noble Tawra, Rakesh Nagar, Rishab Singh and Varun Kaushik, "Voice Operated Intelligent Fire Extinguisher Vehicle", *International Journal of Emerging Trends in Electrical and Electronics (IJETEE)* Vol. 2, No.2, pp. 43-47, April-2013.
- [6] Rutuja Jadar, Rutuja Wadekar, Shweta Khatade, Sayali Dugane, Prof. Dr.S.N. Kini, Fire Fighting Robot Controlled Using Android Application, *International Journal of Innovative Research in Science, Engineering and Technology*, Vol. 5, Issue 5, May 2016.



10.22214/IJRASET



45.98



IMPACT FACTOR:  
7.129



IMPACT FACTOR:  
7.429



# INTERNATIONAL JOURNAL FOR RESEARCH

IN APPLIED SCIENCE & ENGINEERING TECHNOLOGY

Call : 08813907089  (24\*7 Support on Whatsapp)