



IJRASET

International Journal For Research in
Applied Science and Engineering Technology



INTERNATIONAL JOURNAL FOR RESEARCH

IN APPLIED SCIENCE & ENGINEERING TECHNOLOGY

Volume: 10 **Issue:** II **Month of publication:** February 2022

DOI: <https://doi.org/10.22214/ijraset.2022.40243>

www.ijraset.com

Call:  08813907089

E-mail ID: ijraset@gmail.com

IOT Based Person/Wheelchair Fall Detection System

Sayali M. Kamble¹, Pratiksha R. Kawle², Suwarna S. Mohile³, Megha R. Meshram⁴, Prof. Gayatri Padole Mam⁵, Neetu Gyanchandani Mam⁶

^{1, 2, 3, 4}Students of 7th semester B-Tech

⁵Guided By, ⁶HOD-Dr, Department of Electronics & Telecommunication, JD College of Engineering And Management, Nagpur, Maharashtra, India

Abstract: Keeping an in depth tab of recent folks or folks on chair with bound health conditions for his or her health and safety is a very important task. With maturity, weak bones and weakness because of alternative health connected problems could lead to will increase risk of falling. A supervisor might not continually be on the market with them and if correct assistance is not provided at the correct time it should cause larger health considerations which will need extra resources for treatment. For this purpose we've projected a wise IOT Fall Detection System exploitation acceptable sensors that square measure integrated facilitate to assist} report these incidents to assist avail help at the correct time to forestall additional injury to health. The same system uses sensors like associate degree measuring system to live the speed of the person, a rotating mechanism to live the person's orientation so as to live their stability, a load sensing element once the system is employed by an individual employing a chair to live their weight, a Wi-Fi module and a microcontroller that sends the general readings to alert the involved those that shall give with the right suggests that to assist the person in want. The microcontroller receives all the info from the sensors and perpetually transmits and monitors the acceleration and also the orientation of the person. Any fast abrupt modification within the system which will result from a fall is taken into account as a 'fall' and is reported. A serious concern would be that not all fast movement may end up from a fall and be thought of as a matter of concern. To avoid this warning a nap button is provided to snooze the system. This button will be ironed before a definite time say 15-30 seconds to prevent the system from causation the alert, thus avoiding any confusion and panic. This method will be mounted to the person's chair or will be created compact to be created into a wearable device which will be worn on the hand.

Keywords: Measuring system, Gyro meter, Microcontroller

I. INTRODUCTION

Worry of dropping would possibly scale back physical activities leading to declining social interactions and eventually resulting in depression. When it involves maturity, it becomes necessary to observe our recent ones for his or her health and safety. Because of weakness and weak joints they need a good risk of falling down. Currently it's necessary to understand if associate degree adult has fallen in order that he/she will receive timely delivery of medical help. Conjointly folks on wheelchairs ought to be checked for fall detection to minimize the consequences of a fall. Most objective of the merchandise is to form an answer to forestall the intense consequences of a fall whereas providing a convenient usage of the merchandise similarly as alert once a fall event has occurred. All this is often finished the employment of sensors like a rotating mechanism to live the person's orientation and acceleration, a load sensing element to live the burden of an individual United Nations agency is on a chair, a Wi-Fi module and a small controller that sends the general readings to alert the involved folks. this method is formed convenient to use by creating it a wearable device which will be worn on the hand or hooked up to a chair.

II. LITERATURE SURVEY

In venture with the planet Health Organization pretty much 28- 35% of people matured sixty five and over fall every year expanding to 32-42% for those more than seventy years getting on. The recurrence of falls will increment with age and slightness level. A fall recognition framework will be plot as partner degree accommodating gadget whose fundamental target is to caution once a fall occasion has happened. Amid a genuine circumstance, they require the possibility to moderate some of the unfavorable outcomes of a fall. In particular, fall indicators will have an on the spot affect on the decrease inside the stress of falling and furthermore the quick arrangement of assistance once a fall. Indeed, falls and stress of falling depend upon each other. Treatment and social insurance speak to one in all the principal drawing in application zones for the IoT. The IoT can possibly exhibit ascend to a few medicinal applications like remote wellbeing watching, work out regimes, constant maladies and more seasoned consideration. Fluctuated restorative gadgets.

Sensors and indicative and imaging gadgets will be seen as great gadgets or articles comprising a center a piece of IoT. IoT based for the most part tending administrations, downsize cost, increment personal satisfaction and improve client's skill. Postural precariousness and Gait insufficiency undermine the autonomy and prosperity of development people and increment the shot of falls and fall associated wounds. wearable sensors give a transportable and sensible distinctive to the potential client to reduce the possibility of fall. Numerous investigations have appeared more established people related to people on a seat benefit well from access to a method for individual quality. Though a period of the incapacitated network thinks that its troublesome or unrealistic to utilize a seat severally, to oblige this populace analysts have utilized innovations to create wearable gadgets to help people live extra severally. Plus, the greater part of their potential clients not being receptive to their reality, when the build of fall identification is gave, they see in it a decent potential to help their security and well being in home.

III. SYSTEM ARCHITECTURE

This system also embraces the same concept of wearable devices mentioned above. The system is equipped with sensors that monitors the vital senses of the person and reports constantly. Any abrupt or sudden changes in these values are taken as an anomaly and reported. The system makes use of the following sensors i.e. a gyro meter, an accelerometer and a load sensor in the case of wheelchair. These sensors measure the orientation of the person, their speed and their weight. These sensors are calibrated under standard conditions and when a person falls down, and a threshold is determined. This threshold values is taken as a reference value to compare against the incoming readings from the sensors. If a major deviation is measured from the reference value then we can assume that the person has fallen. Since the main aim is to provide help to the person as soon as possible an alert is sent to the concerned person in the form of a message informing them about the condition. An alarm also goes off to notify people nearby to get their attention and receive help. Sometimes the difference in the values of the sensor may not be from a fall but due to some other circumstances as well. To avoid a false alarm it is, advisable to add a snooze button that may be turned on before the message is sent. Hence it is necessary to have a time interval of a few seconds to a minute between the fall detection and the sending of alert message.

The major stumbling block is to identify the sensors and their integration since different medical condition may require different sensors. Many test cases need to be defined to calculate the average and the threshold values of these sensors.

IV. BLOCK DIAGRAM

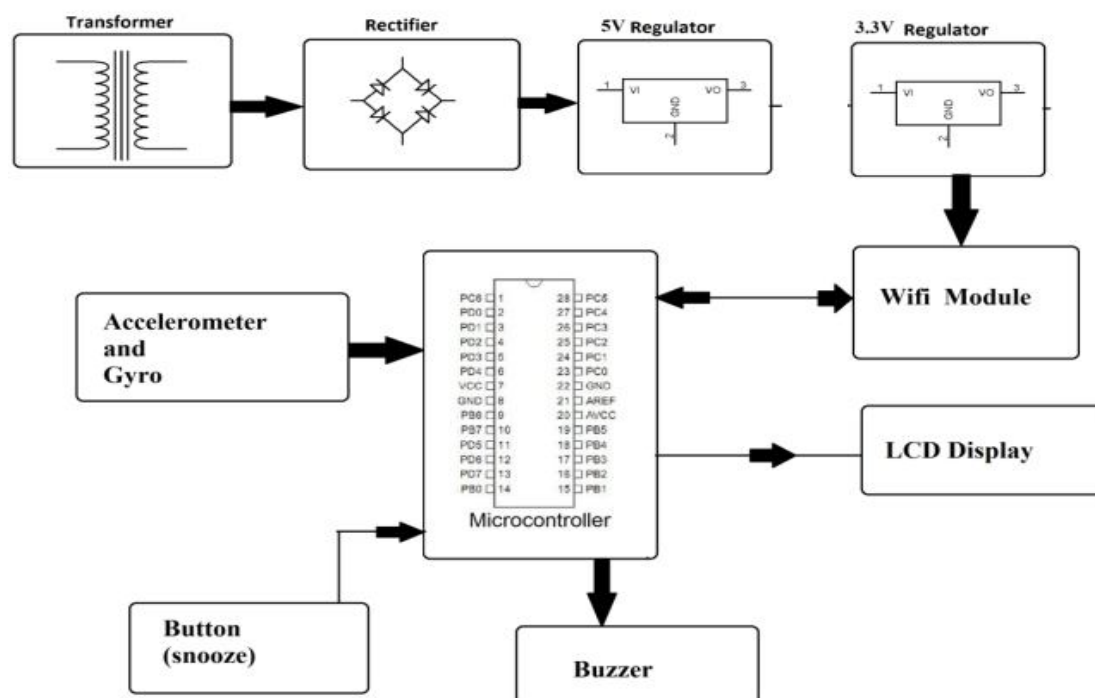

V. HARDWARE SPECIFICATIONS

- A. Atmega Microcontroller
- B. Crystal Oscillator
- C. Capacitors
- D. Resistors
- E. Transistors
- F. Diodes
- G. LED
- H. Accelerometer Gyro
- I. ESP8266 wifi Module
- J. Switch
- K. IC
- L. Transformer/Adapter
- M. Cables & Connectors
- N. Push Botton
- O. PCB

VI. SOFTWARE SPECIFICATIONS

- A. Arduino Compiler
- B. MC Programming Language: C
- C. IOT Gecko

VII. CIRCUIT DIAGRAM

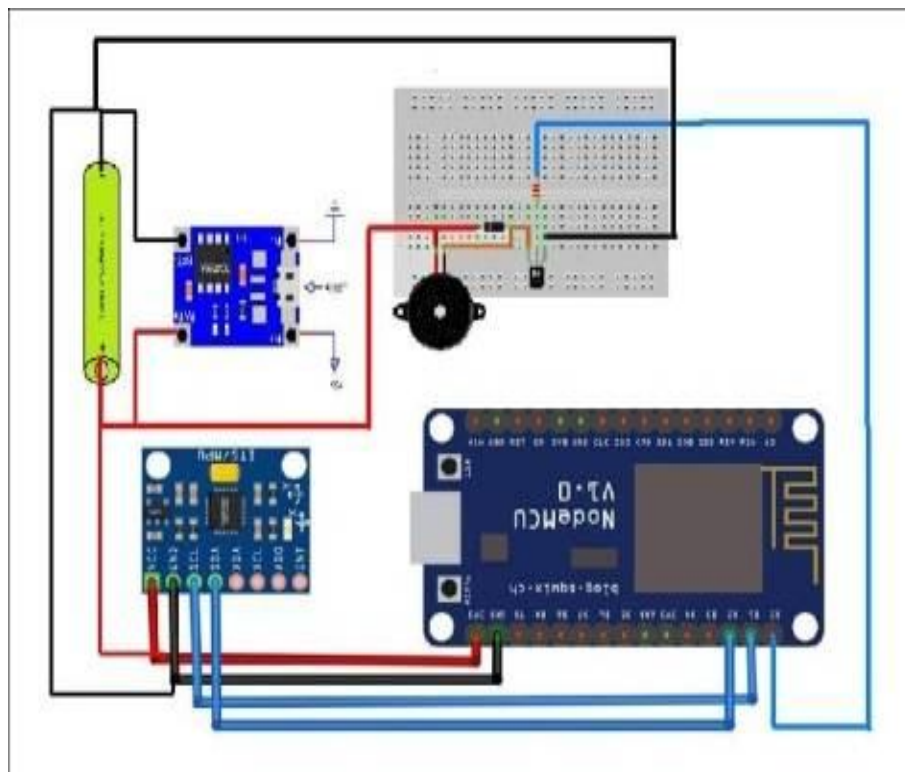

Fig.1 Circuit Diagram

VIII. FLOW CHART

The following figure is a flowchart that depicts the flow of things; it explains how the system works and also gives a brief description of how the system works along with the order of execution of the proposed system.

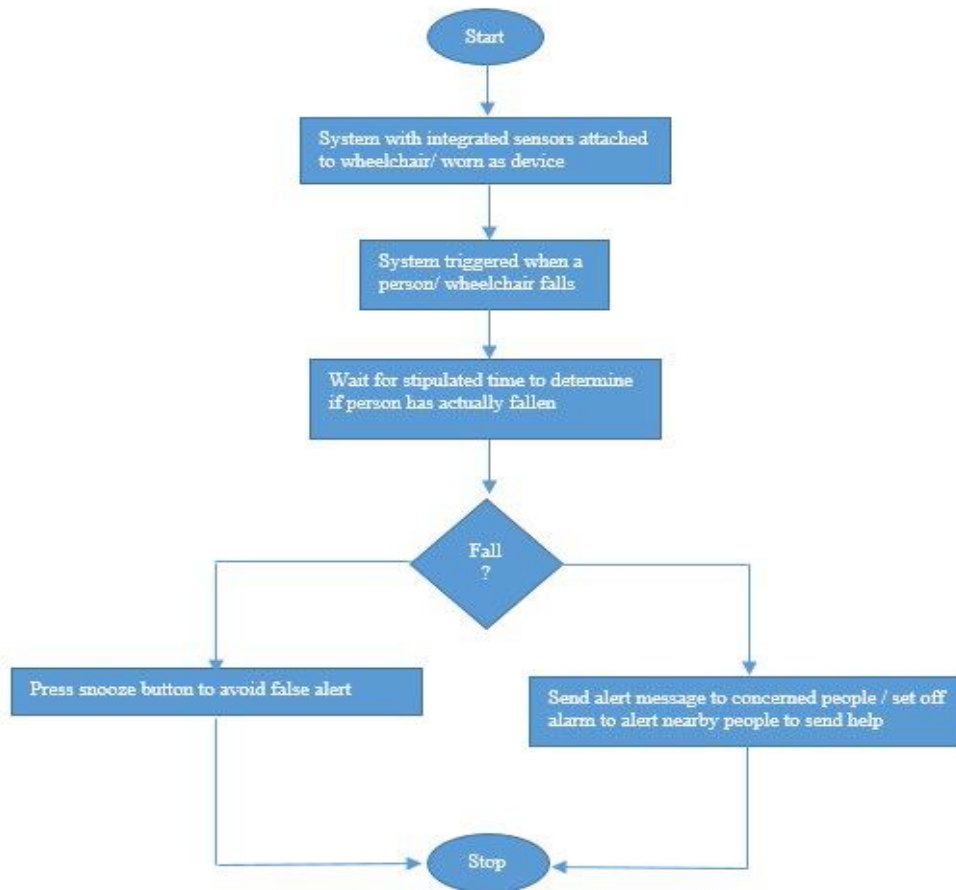

Fig.2 Flow chart

IX. ADVANTAGES

- 1) Easy to reach,
- 2) Light weight,
- 3) Low cost,
- 4) Easy to wear & remove.

X. DISADVANTAGE

High false alarm rate due to frequent hand movement.

XI. APPLICATIONS

- 1) Hospitals,
- 2) Military applications,
- 3) Monitoring patients at home.

XII.FUTURE WORKS

In the future, if the proposed algorithms are implemented to the embedded system, its performance will be tested in a real time. Also we will try to include a GPS tracker in it. And this system can be further developed into an intelligent system that works on machine intelligence to help report with other various medical conditions with the help of other sensors.



REFERENCES

- [1] Design and Implementation of an IOT Based Person Fall Detection & Wheelchair by using Nodemcu and Arduino. <http://ijceng.com/gallery/35.cej-2226.f.pdf>
- [2] Smart Fall Detection System for Elderly People with IOT and Sensor. https://www.rcciit.org/students_projects/projects/ee/2021/GR9.pdf
- [3] IoT Based Smart Wheelchair System. <file:///C:/Users/ADMIN/Downloads/IoT%20Based%20Smart%20Wheelchair%20System%20Formatted%20Paper.pdf>
- [4] An IoT Based System to Detect a Person/Wheelchair Fall, https://www.researchgate.net/publication/330993777_An_IoT_Based_System_to_Detect_a_PersonWheelchair_Fal
- [5] IoT Based Wheel Chair Fall Detection https://papers.ssrn.com/sol3/papers.cfm?abstract_id=391835
- [6] A Novel Approach for Smart and Cost Effective IoT Based Elderly Fall Detection System Using PiCamera. <https://ieeexplore.ieee.org/document/8524486>
- [7] Implementation of Cloud IoT - Based Patient Fall Detection System with Geo Tagging using Tilt Sensors and Texas Instruments' CC3200, <https://indjst.org/articles/implementation-of-cloud-iot-based-patient-fall-detection-system-with-geotagging-using-tilt-sensors-and-texas-instruments-cc3200>



10.22214/IJRASET



45.98



IMPACT FACTOR:
7.129



IMPACT FACTOR:
7.429



INTERNATIONAL JOURNAL FOR RESEARCH

IN APPLIED SCIENCE & ENGINEERING TECHNOLOGY

Call : 08813907089  (24*7 Support on Whatsapp)