



# IJRASET

International Journal For Research in  
Applied Science and Engineering Technology



# INTERNATIONAL JOURNAL FOR RESEARCH

IN APPLIED SCIENCE & ENGINEERING TECHNOLOGY

**Volume:** 11    **Issue:** X    **Month of publication:** October 2023

**DOI:** <https://doi.org/10.22214/ijraset.2023.56420>

[www.ijraset.com](http://www.ijraset.com)

Call:  08813907089

E-mail ID: [ijraset@gmail.com](mailto:ijraset@gmail.com)

# Pawsitive Practices: A Comprehensive Approach to Veterinary Care for Animals

Mrs. M. S. Sawalkar<sup>1</sup>, Rutuparn Sadvelkar<sup>2</sup>, Nirupama Ambre<sup>3</sup>, Pratik Patil<sup>4</sup>, Mansi Jadhav<sup>5</sup>

<sup>1</sup>Assistant Professor, Department of Computer Engineering, JSPM Narhe Technical Campus, Narhe, Pune

<sup>2, 3, 4, 5</sup>Student, B.E. in Computer Engineering, JSPM Narhe Technical Campus, Narhe, Pune

**Abstract:** *"Pawsitive Practices: A Comprehensive Approach to Veterinary Care for Animals" is a pioneering research paper that delves into the intricacies of a Veterinary Care Management System (VCMS). The system serves as a pivotal platform fostering enhanced interaction between veterinarians, their assistants, and pet owners, with the overarching goal of advancing animal healthcare and welfare.*

*Central to this system is the dynamic "VET PLUS" application, which provides a detailed compendium of information pertaining to a diverse array of animals, including cattle, buffalo, sheep, goats, dogs, and rabbits. Additionally, the VCMS offers a wealth of resources, covering essential aspects such as breeds, dietary guidelines, specialized care protocols, government schemes and loans, feeding and nutritional recommendations, reproductive insights, subsidies, climatic considerations, associated benefits, vaccination procedures, prevalent diseases, and insurance coverage.*

*This comprehensive system acts as an invaluable bridge, facilitating seamless communication between farmers and veterinary professionals through an integrated chat box, thereby enabling effective guidance and support for optimal animal health and well-being. "Pawsitive Practices" not only underscores the significance of holistic veterinary care but also underscores the pivotal role of technology in fostering an interconnected and compassionate approach to animal welfare.*

**Keywords:** *Emergency Handling, Animal Healthcare, Pet Information Management, Feeding and Nutritional Recommendations, Vaccination Procedures, Farmer – Veterinarian Interaction, Holistic Veterinary Care.*

## I. INTRODUCTION

In the intricate web of life, the well-being of our cherished animal companions stands as a testament to the deeply ingrained bond that exists between humans and the diverse species that grace our world. Within this intricate tapestry, veterinary care emerges as a cornerstone, embodying a profound commitment to safeguarding the health and vitality of our beloved furry, feathered, and scaly friends. Grounded in the profound ethos of "Pawsitive Practices," the Veterinary Care Management System (VCMS) serves as a beacon of hope and progress, heralding a new era in comprehensive animal healthcare and welfare.

Imagine a world where the touch of a caring hand and the assurance of expert guidance converge seamlessly to create an environment that nurtures the physical and emotional well-being of animals. Here, the virtuosity of modern technology intertwines with the heartfelt compassion that defines the essence of veterinary care, encapsulating a paradigm shift that transcends traditional boundaries and paves the way for a more holistic and integrated approach to nurturing the health of our animal companions.

At the heart of this transformative system resides the all-encompassing 'VET PLUS' application, a dynamic platform that acts as an invaluable reservoir of knowledge, catering to the multifaceted needs of diverse animal species. From cattle and buffalo to sheep, goats, dogs, and rabbits, the application serves as a virtual compendium, offering comprehensive insights into various breeds, nuanced dietary guidelines tailored to specific species, intricate care protocols aimed at addressing individualized health concerns, and a comprehensive overview of government-endorsed schemes and financial support systems designed to bolster animal welfare efforts. As the wheel of time continues to turn, the VCMS embodies a potent amalgamation of cutting-edge technological innovations and the enduring wisdom that stems from the tireless efforts of the veterinary community. With a keen focus on fostering informed decision-making and proactive participation in the care of our animal companions, the system facilitates seamless access to vital information pertaining to essential vaccination procedures and comprehensive insurance coverage, thereby providing a robust safety net for both pets and their owners. It is within the intricate fabric of this visionary framework that the true essence of holistic animal care comes to life. Whether it's the careful management of dietary needs to ensure optimal nutrition, the meticulous scheduling of timely vaccinations to prevent the onset of preventable diseases, or the swift mobilization of expert guidance during unforeseen emergencies, the VCMS stands resolute as a bastion of support and compassion, underlining its unwavering commitment to nurturing enduring bonds and fostering vibrant, fulfilling lives for our cherished animal companions.

In the tapestry of life's intricate design, every wag of a tail, every joyful bark, and every contented purr serve as a poignant reminder of the profound impact that the VCMS continues to make in shaping the narrative of modern veterinary care. Through its unwavering dedication to excellence, compassion, and progress, the system serves as a testament to the timeless bond that unites us with our faithful animal friends, encapsulating a vision of wellness and vitality that transcends the limitations of time and space.

## II. OBJECTIVES

- 1) Crafting a Seamless Mobile Experience for Pet Owners.
- 2) Facilitating Easy Access to Expert Veterinary Services.
- 3) Efficiently Managing and Monitoring Pet Health Records.
- 4) Championing Comprehensive Pet Well-being Initiatives.
- 5) Implementing Real-time Pet Health Monitoring Solutions.
- 6) Fostering Seamless Collaboration with Veterinary Experts.
- 7) Ensuring Smooth Operation Across Multiple Platforms.
- 8) Ensuring Robust Data Security and Privacy Measures.
- 9) Empowering Users with Comprehensive Training and Support.
- 10) Empowering Pet Owners with Timely Health Reminders and Alerts.

## III. LITERATURE SURVEY

Several studies have contributed to the advancement of veterinary care and pet management systems, each highlighting essential aspects and potential areas for improvement.

Diana Conde López, Lesdi Gavilán Colca, Laberiano Andrade-arenas, and Michael Cabanillas-carbonell (2023) successfully designed a mobile application for controlling and managing pet care, showcasing the potential for streamlined pet care management. However, the study could further explore the integration of advanced monitoring features and telemedicine solutions to provide comprehensive and remote pet healthcare services, addressing potential gaps in remote pet care management.

Gaurav Lambat, Akanksha Korde, Dhanshree Moundekar, Pranjali Nasre, Suyesha Tokekar, and Vishakha Hude (2019) developed an Android application focused on animal welfare, emphasizing the importance of technology in fostering compassion and care for animals. The study could benefit from incorporating features that facilitate user engagement and community participation in animal welfare initiatives, thereby bridging potential gaps between individual efforts and collective impact in the realm of animal welfare.

Tushar Shelke, Shaksham Shahu, Aditi Godar, Manisha Talewar, and Jyoti Thaker (2022) concentrated on the design and development of an Android-based application catering to the multifaceted needs of animal healthcare. To enhance the application's efficacy, the research could explore the integration of AI-driven diagnostic tools and real-time data analytics to facilitate prompt and accurate diagnosis, addressing potential gaps in advanced diagnostic capabilities and data-driven insights for comprehensive animal healthcare.

A. Noraziah, Noor Naimah, and M. Nasratun (2020) implemented an Android application to streamline the management of products and services offered by Klinik Veterinar & Surgeri Jawhari, emphasizing the importance of efficient management systems in the context of pet-related businesses. The research could delve deeper into exploring the integration of customer feedback mechanisms and personalized service offerings to bridge potential gaps in enhancing customer engagement and satisfaction within the pet shop management context.

Yeshwin Anil, Archana Sahoo, and Powel Shoby (2020) created a Pet Friendly Management System using Flutter and Firebase, emphasizing the significance of accessible and user-friendly pet care solutions. To address potential gaps, the research could focus on incorporating tailored pet care recommendations and behavior tracking features, fostering a more personalized and attentive approach to pet care management and improving the overall pet-owner relationship.

- 1) *Telemedicine Integration*: Enable remote consultations between veterinarians and pet owners for real-time guidance.
- 2) *Automated Appointment Reminders*: Send timely notifications for upcoming vaccinations and check-ups.
- 3) *AI-Powered Diagnostic Support*: Implement AI-driven tools for early detection of health issues in animals.
- 4) *Emergency Alert System*: Establish a mechanism for immediate communication during critical situations.
- 5) *Integration with E-commerce Platforms*: Provide access to recommended pet products and medications through the system.

#### IV.FLOWCHART

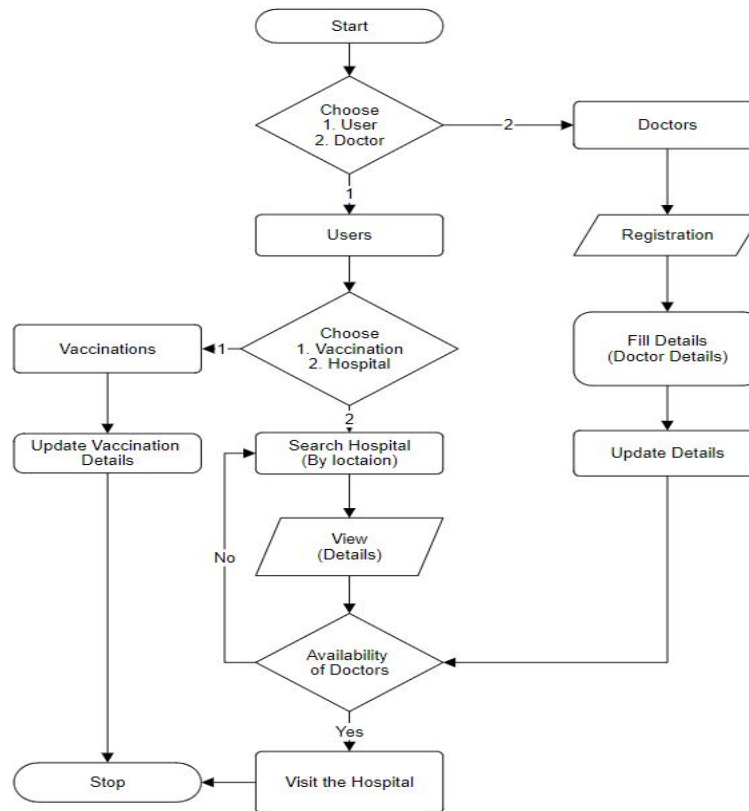

#### V. COMPONENT DIAGRAM

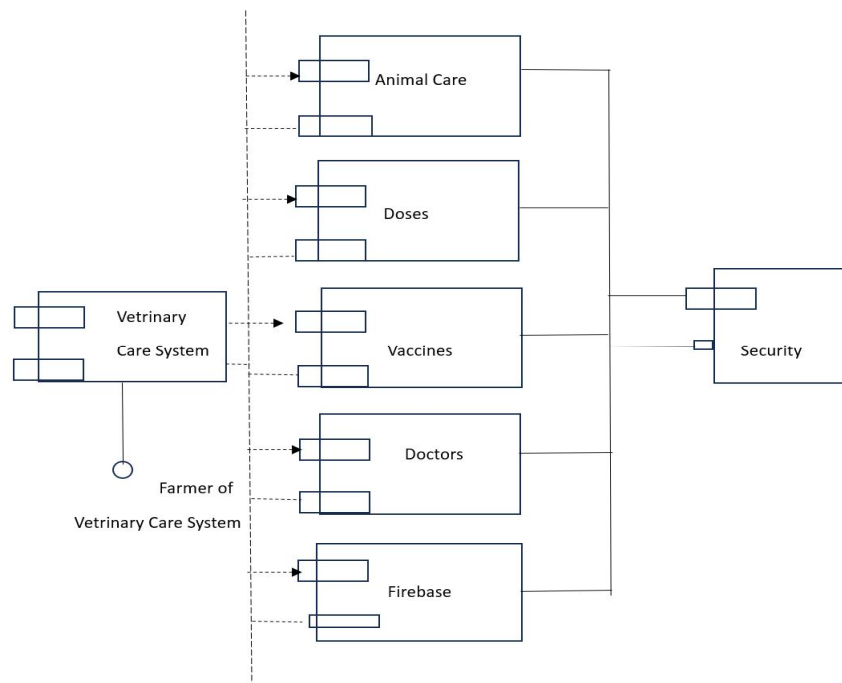



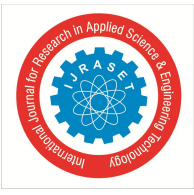

## VI.CONCLUSION

Veterinarians stand as the steadfast guardians of animal well-being, overseeing diverse facets of health management, reproductive care, and injury prevention. With a crucial role in animal reproduction, conservation, and preventive medicine, their expertise spans nutrition, biosecurity, and beyond.

Through the intuitive application, users experience a seamless journey in pet management, effortlessly scheduling appointments, and swiftly reporting emergencies. This dynamic system champions proactive animal care, guaranteeing prompt medical attention and fostering a community of well-informed and dedicated pet owners.

Empowered with the authority to approve or decline appointment requests, veterinarians curate a manageable schedule, all while actively engaging with users, contributing to a vibrant and knowledgeable network of passionate pet enthusiasts.

## REFERENCES

- [1] Diana Conde López, Lesdi Gavilán Colca, Laberiano Andrade-arenas, and Michael Cabanillas-carbonell. "Design of a Mobile Application for the control of pet care." (2023).
- [2] Gaurav Lambat, Akanksha Korde, Dhanshree Moundekar, Pranjali Nasre, Suyesha Tokekar, and Vishakha Hude. "An Android Application for Animal Welfare." (2019).
- [3] Tushar Shelke, Shaksham Shahu, Aditi Godar, Manisha Talewar, and Jyoti Thaker. "Design and Development of Android based animal Healthcare Application." (2022).
- [4] A. Noraziah, Noor Naimah, and M. Nasratun. "Pet Shop Management System for Klinik Veterinar & Surgeri Jawhari." (2020).
- [5] Yeshwin Anil, Archana Sahoo, and Powel Shoby. "A Pet-Friendly Application using Flutter and Firebase." (2020).
- [6] Kiran Narasimha Dixit, Krishnamoorti Bhat, and Prof. Saravanan C. "Android Application for Veterinary Health Care and Product." (2022).



10.22214/IJRASET



45.98



IMPACT FACTOR:  
7.129



IMPACT FACTOR:  
7.429



# INTERNATIONAL JOURNAL FOR RESEARCH

IN APPLIED SCIENCE & ENGINEERING TECHNOLOGY

Call : 08813907089  (24\*7 Support on Whatsapp)