



IJRASET

International Journal For Research in
Applied Science and Engineering Technology



INTERNATIONAL JOURNAL FOR RESEARCH

IN APPLIED SCIENCE & ENGINEERING TECHNOLOGY

Volume: 9 Issue: XI Month of publication: November 2021

DOI: <https://doi.org/10.22214/ijraset.2021.38938>

www.ijraset.com

Call:  08813907089

E-mail ID: ijraset@gmail.com

Performance of IUPQC for Multi-Feeder Systems using Particle Swarm Optimization (PSO) and Multilevel-Inverter with Grid Integration of Hybrid Renewable Energy System

Pottipati Sai Gangadhar¹, P. Rizwan²,

¹Post Graduate Student, ²Assitant Professor (Adhoc), Dept. of Electrical and Electronics Engineering, JNTUACEA, Anantapur, Andhra Pradesh, India

Abstract: An ordinary PID system and an anti PID saturation technique are used to confirm the dominance of the proposed approach in a wind structure with exchange work. The simulation is performed in MATLAB to designate the predominance of the anticipated calculation. The replica mould is shown in the image. Figure 9 depicts the controller surface waveforms in relation to the planned computation, where the level directions are instance t and the upward arrangements in are input esteem. In the end, the proposed method is capable of deciphering a symphonic disguise. There is a 0.9993-second lag between the factor power and 1, which means the factor power is very close to 1. New power-electronic devices, dubbed "Specific Power Devices," are being developed to reduce power quality problems and provide customers with tailored solutions. Modern solutions for load-related issues and supply voltage flaws are included in UPQC, which stands for Unified Power Quality Conditioners. Shunt Compensation and Series Compensation work together to solve many power quality issues. The series compensator's current and voltage profiles are improved thanks to the shunt compensator. Custom feeding systems have emerged as a result of the assumption that a healthy feeder next to it can compensate for issues in the current feeding unit. With these devices, you'll get better performance than with a unique power supply for each feeder. These unique power devices include the IDVR, IVOLCON, and IUPQC with two voltage stabilisation capacitors, as well as the Interline Dynamic Voltage Restored (IDVR). The use of a new IUPQC topology that concurrently compensates for voltage and current impurities while also improving Power Quality Quality. In typical approaches, four voltage source converters (VSC) with multi-tier topologies are taken into account, and a hexagonal coordinate system space vector pulse width modulation is employed. The PI controller improves power quality while reducing status errors. Because of these drawbacks, the PI controller isn't the best choice for high-reliability applications. Particle Swarm Optimization uses the PI controller installation to further increase power quality (PSO). The IUPQC with Particle Swarm Optimization (PSO) stabilises voltage and current discrepancies for improved power quality in the multi-bus/multi-feeder system. In order to compensate for voltage changes, a proposed controller utilises a shared capacitor to distribute voltage from healthy feeds to neighbouring feeders. Two feeders with a hybrid renewable energy system implement the researchers' technique. MATLAB/SIMULINK was used to analyse IUPQC's results.

Keywords: Grid Integrati0n, Multi-Feeder Systems, Multi-Level C0nverters, P0wer Quality Impr0vement, Renewable Energy Systems

I. INTRODUCTION

Unreliable and poor-quality electricity are key issues today's electricity networks. Many issues can arise as a result, such as malfunction, instability, and a decreased lifespan. Understanding and correcting power quality issues are essential since they need an understanding of both the problems and the solutions. APFs (Active Power Filters) are superior than passive filters for solving power quality concerns because they are active and have the potential to react rapidly. Power system equipment frequently encounters transitory problems. In series APF power quality adjustment, voltage sag, swell, and harmonics are the key issues to be addressed. APF helps to correct load current-related problems like a low power factor, imbalance, and harmonics. UPQC is a set in series with common DC link capacitor between two back-to-back APFs. Unified Power Quality Control is a powerful tool for dealing with power quality problems (UPQC). A number of converters can be used to improve the PQ of nearby feeders, as demonstrated in this article. the Interline Unified Unified Power Quality Conditioner, a power quality conditioner.

The IUPQC has two converters: a series and a shunt. Having two feeders is a result of the fault level at the Common Coupling Point regarded as two separate sources (PCC). IUPQC [11] utilises a pair of VSCs with one converter shunted to one feeder and the other converter linked in series to the other feeder for efficiency. The first feeder's current profile and the second feeder's voltage profile are both enhanced in this design. In this context, the addition of a third converter with distinct nomenclature like UPQC [13], DS – UniCon[12] and MC-UPQC with 3 VSCs opens up a slew of new possibilities. Unified power quality conditioning system layout with four VSC bus/multi-feeder systems in parallel, IUPQC. Between the grid and the HRES, the suggested IUPQC is implemented [17]. It introduces an interline UPQC, a new connector for a UPQC (IUPQC). IUPQC-connected distribution system with a single-line diagram is depicted in Figure 1. It is fed by two feeders, one connected to a substation and the other to two more substations. V_{s1} and V_{s2} stand for the input and output supply voltages, respectively (from HRES). To begin, let's say the IUPQC is connected to two buses, one named B-1 and the other named B-2. In addition, Feeder currents are designated by I_{s1} and I_{s2} , whereas load currents are designated by I_{L1} and I_{L2} . The voltage at the circuit's load end is denoted by the letter V_{L2} .

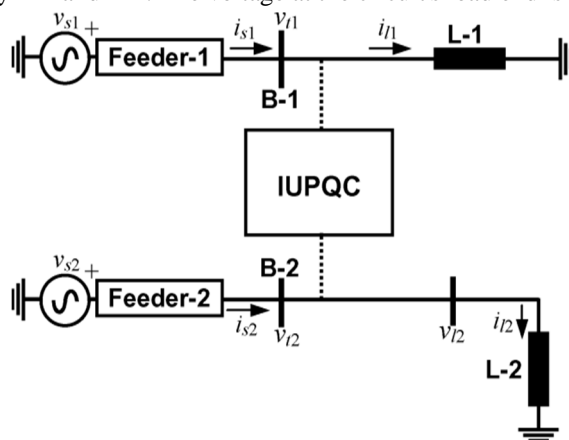

Fig 1: Single line diagram of IUPQC

In order to prevent voltage sag/swell, a temporary stoppage in either of the two feeders, the IUPQC's goal is to keep V_{t1} and V_{t2} constant. One feeder (let's call it Feeder-1) has been shown to be able to absorb power from the IUPQC in order to keep V_{L2} constant when the voltage drops. This is possible due to the fact that a single DC capacitor powers both VSCs. The voltage control of DC capacitors and the approach for generating a voltage reference have been explored in this article. Additionally, the performance ceilings have been calculated.

II. STRUCTURE AND CONTROL

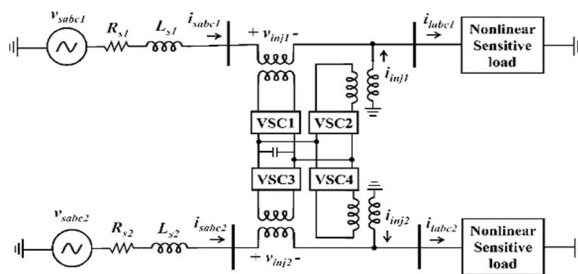

Fig2: Single line diagram of four converter

Topology for multi-feeder system control of series inverters Voltage injection schemes and methods for creating gates Gate signals. Sag/swell detection. Control of shunt inverters Methods for producing gate signals, as well as control of capacitor voltage, are all examples of current reference generation.

VSC Converters with Shunt and Series Feedback: A Control Strategy

Series VSC uses Sinusoidal Pulse Width Modulation (SPWM) voltage control and shunt VSC uses hysteresis current control as the switching control approach. Shunt-VSC In order to counteract the reactive component of load $L1$ current, the shunt-VSC has the following functions:

To account for harmonics in the load L1 current

The common dc-link capacitor's voltage is regulated using this circuit. The shunt VSC control block diagram is shown in Figure 3. To create a synchronous reference frame, the measured load current (I_{abc}) must be translated (dq0)

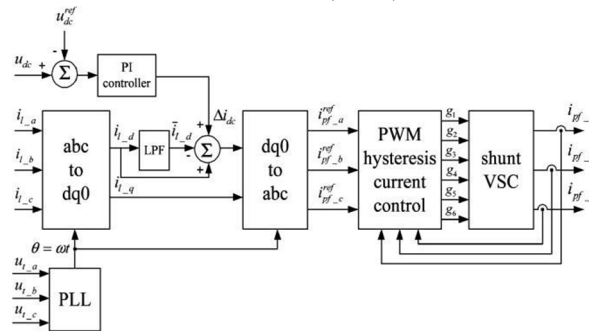

Fig 3: PWM hysteresis current control block diagram for the shunt VSC

Low-Pass Filters may easily recover the fundamental positive-sequence component using this transform, which converts AC quantities in the and axes to DC quantities (LPFs). Additionally, a fundamental frequency shift converts all harmonic amounts to alternating current (AC). The voltage drop in the Switching losses are responsible for the DC-link capacitor. Other interruptions, such as a sudden change in load, can impair the DC link. Figure 3 employs a PI controller to regulate the DC-link capacitor voltage. The difference in voltage between the real capacitor and the reference voltage is fed into the PI controller. Each phase's output-compensating currents are calculated via PWM hysteresis current control.

III. SERIES-VSC

Functions Of the series VSCs in each feeder are

- 1) To mitigate voltage sag and swell
- 2) To compensate for voltage distortions, such as harmonics
- 3) To compensate for interruptions

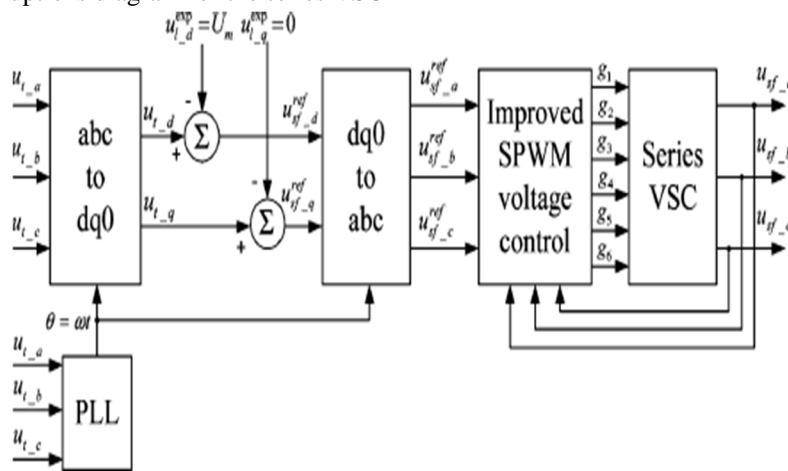

Fig. 4: Improved SPWM Voltage Control block

Figure 4 depicts the series VSC control block diagram. In order to create the synchronous reference frame, the bus voltage must first be recognised and translated into it (dq0). The series VSC output compensation voltage can be produced by utilising an enhanced SPWM voltage management approach [3]. To change the VSC's power supply into three-level power supplies, the suggested system will use the multilevel converters. As an alternative to SVPWM, many MLC approaches are available, such as the sinusoidal triangular comparison, selective harmonic removal, and hysteresis mentioned above. As a result, common mode distortion is less of an issue.

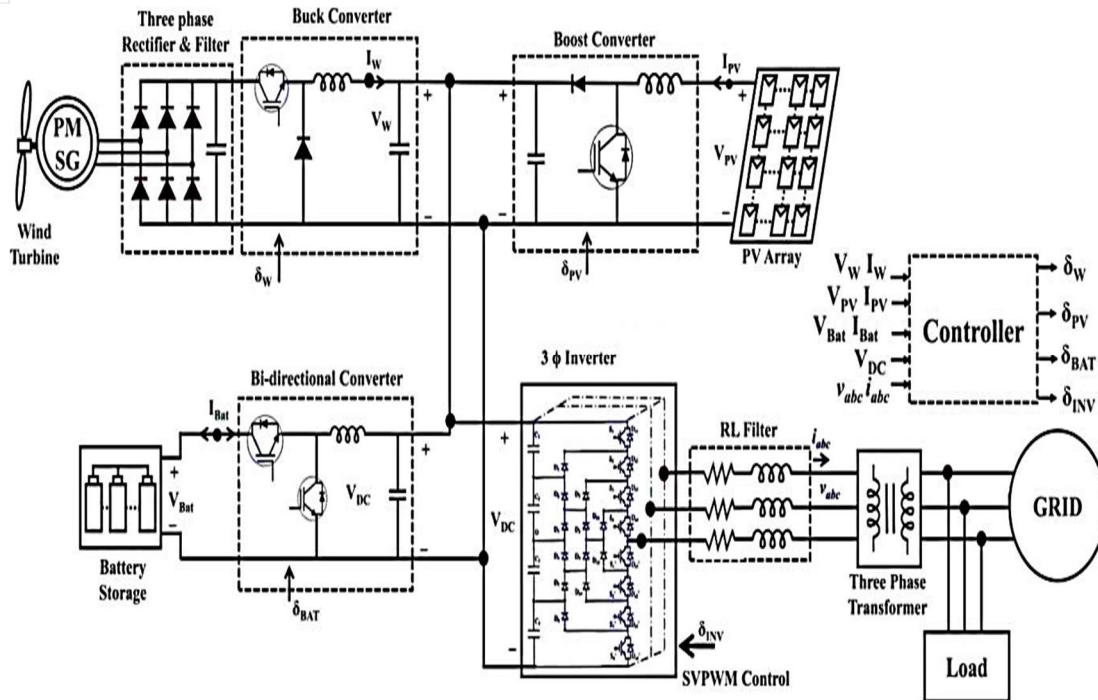

Fig5: Schematic diagram Of HRES

In multi-bus/multi-feeder systems, an unique architecture of IUPQC with PI controller can simultaneously compensate for both voltage and current defects to improve power quality. It uses four voltage-source converters (VSC) and a hexagonal space vector pulse width modulation scheme, which is the conventional way. The steady state error is reduced, and the power quality is improved, thanks to the PI controller. The fundamental disadvantage of PI controllers is that they are less stable, have a slower response time to disturbances, and are more sensitive to controller gain changes. Particle Swarm Optimization (PSO) is utilised instead of a PI controller to further increase the quality of the power.

To improve power quality, use the IUPQC and Particle Swarm Optimization (PSO) for multi-bus/multi-feeder systems, which maintain stability by correcting for both voltage and current differences on an ongoing basis.

IV. PARTICLE SWARM OPTIMIZATION METHOD

Multi-agent parallel search is what PSO is all about. The multi-dimensional search space is filled with particles flying around. Each particle has a known position and speed at any given time. A trail solution to the search issue is represented by a particle's location vector with respect to the search space origin. To begin, the Vectors X_i denote a population of particles that starts out with random coordinates and random velocities. Swarm S is the collective noun for this group. It has been established that N is a neighbourhood relation in the swarm Particles P_i and P_j are neighbours if N is greater than 0.

$$V_{id}(t+1) = \omega V_{id}(t) + C_1 \phi_1 (P_{d}(t) - X_{id}(t)) + C_2 \phi_2 (g_{d}(t) - X_{id}(t)) \quad \text{--- (1)}$$

$$X_{id}(t+1) = X_{id}(t) + V_{id}(t+1) \quad \text{----- (2)}$$

The i th particle's position and velocity are shown in equations for the d th dimension. The particle's inertial velocity is represented by the initial part of the formula for updating the speed. The phrase "cognitive part" refers to the second term in which $p(t)$ represents each particle's own experience. A "social term" describes how an individual particle is affected by the actions of the other people in a community. With V_{max} , you're talking about the utmost speed possible. C_1 and C_2 are two constants commonly referred to as "self-confidence" and "swarm confidence" in psychology, respectively. $p(t)$ and $g(t)$ alter the velocity update formula, according to these researchers. C_1 and C_2 are uniformly distributed random values.

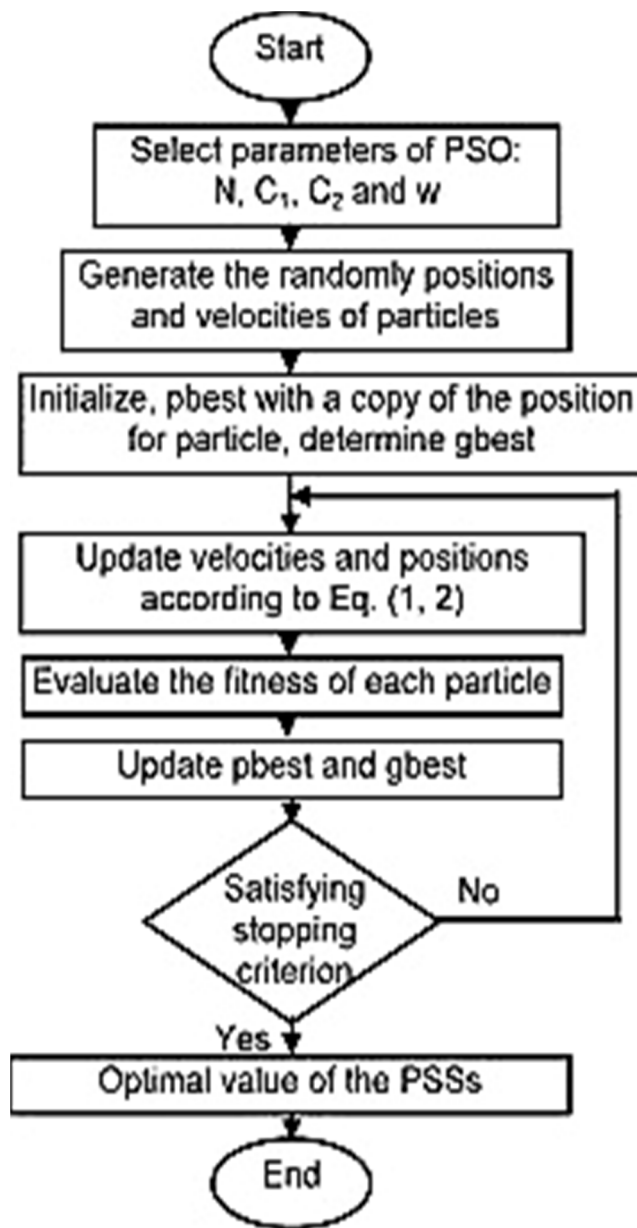

A. PSO Algorithm

- 1) Step1: Initialization-initialize all particles as per the above algorithm
- 2) Step2: Set iteration count=0
- 3) Step3: Evaluate the fitness function i.e. the Load Balancing Index for the each particle and fix the individual LBI to Pbest and from LBI of all the particles find the minimum LBI the fix it as Gbest for this iteration
- 4) Step4: Evaluate the velocity of each population by using the equation. $Velocity = w * velocity + c1*(R1.*(local\ best\ position - current\ position)) + c2*(R2.*(global\ best\ position - current\ position))$
- 5) Step5: Update the position of each population
- 6) Step6: Find the new values of fitness function (LBI) for all the population and replace it with Pbest if it less than the former value and also fix the least value of Pbest among all the population to Gbest
- 7) Step7: Increase the iteration count by 1
- 8) Step8: Check the stopping criterion; if not satisfied go to step3 Finally the optimum solution can be obtained through "Gbest".

V. SIMULATION RESULTS USING PSO

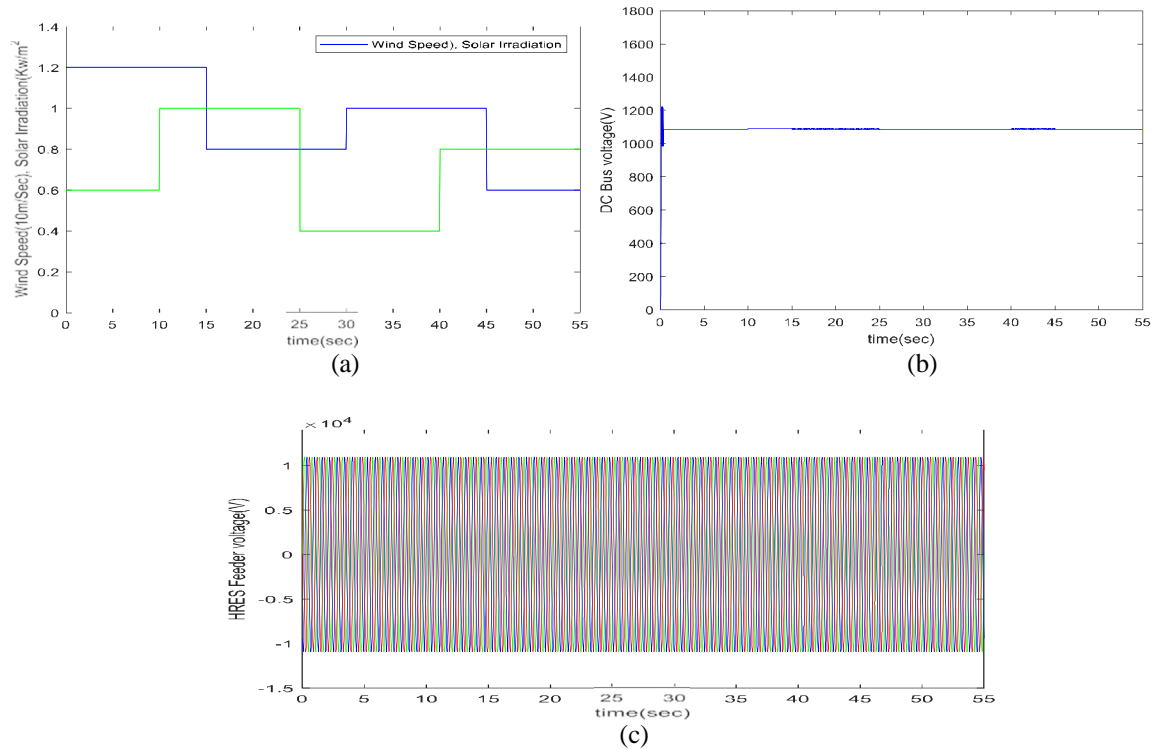

Fig.6: (a) Solar irradiance and wind speed level (b) DC Bus voltage (c) HRES feeder voltage

For the purposes of testing the HRES's performance, the solar irradiance and wind speed are changed as shown in fig. 6 (a). Although wind speed and solar radiation vary, DC bus tension remains constant at 1kV. The BEES are responsible for maintaining a consistent DC bus voltage. As can be seen in Fig. c, the voltage at the secondary transformer's output is a constant 11kV due to the DC bus's constant voltage. Stable voltage and frequency can be loaded using HRES technology.

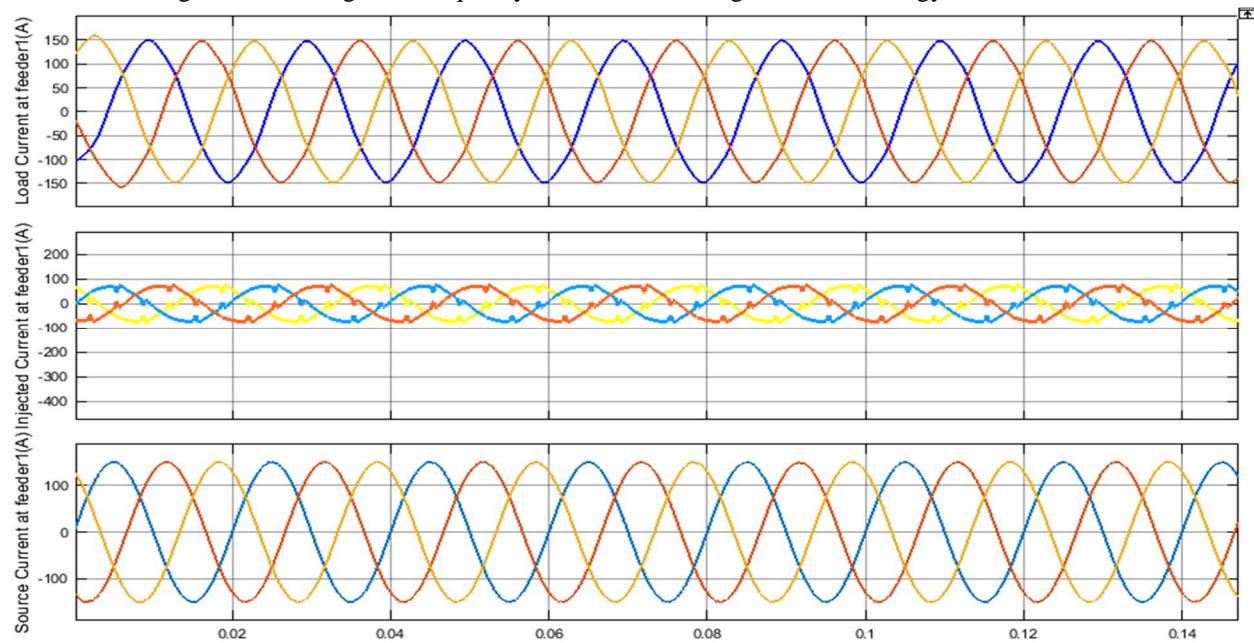

Fig. 7: Voltages and currents at feeder 1

The suggested IUPQC architecture for two feeders systems and control systems has been thoroughly evaluated in a full case study. The 11kV, two-phase, three-wire, and 50-Hz power systems are scrutinised. Discussion and results are provided on IUPQC's performance. IUPQC's performance is evaluated in a number of different scenarios that deal with varying degrees of power quality issues. Non-linear loads and voltage faults, such as slant/slope and voltage harmonics, cause these current harmonics.

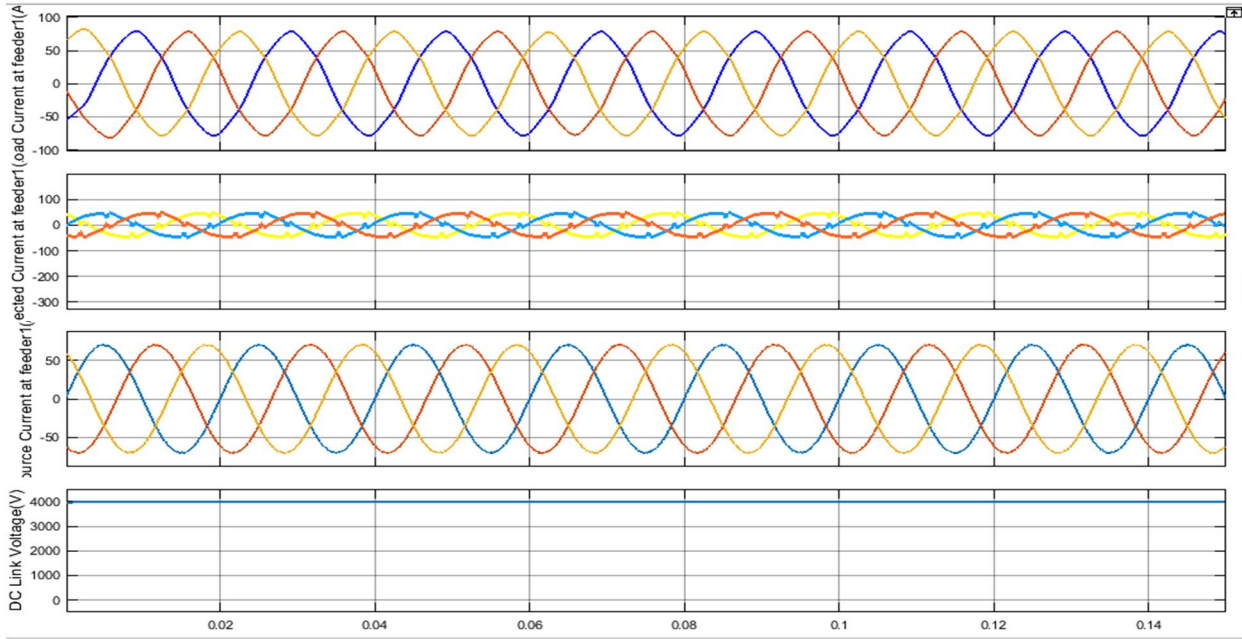
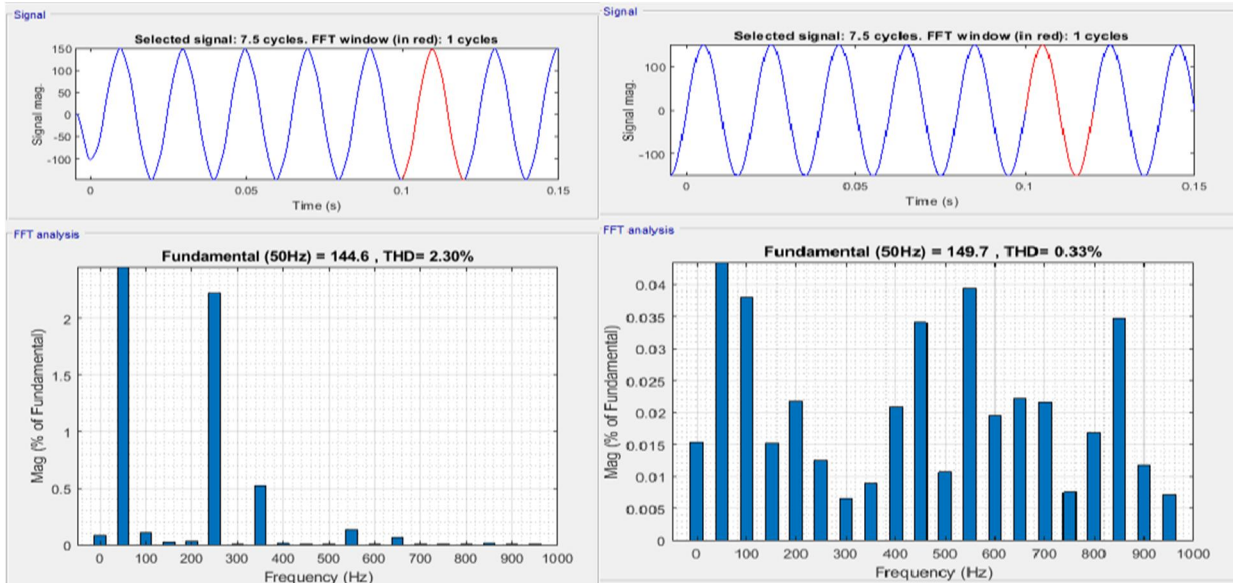

Fig.8: Voltages and currents at feeder 2, DC link voltage



Load current at feeder 1

Source current at feeder 1

Fig. 9: FFT analysis of feeder 1

Feeders 1 and 2 feed nonlinear loads with resistive loads of 100 ohms and 140 ohms, respectively, via a diode bridge rectifier. Figures 11 and 12 show that non-linear loads and source currents cause the load currents to have a harmonious composition. Reduced THD from 2.03% from load current to source current, and from 2.70% on the first feeder down to 2.59 percent on the second. Figures 9 and 10 show the results of an FFT analysis based on THD measurements.

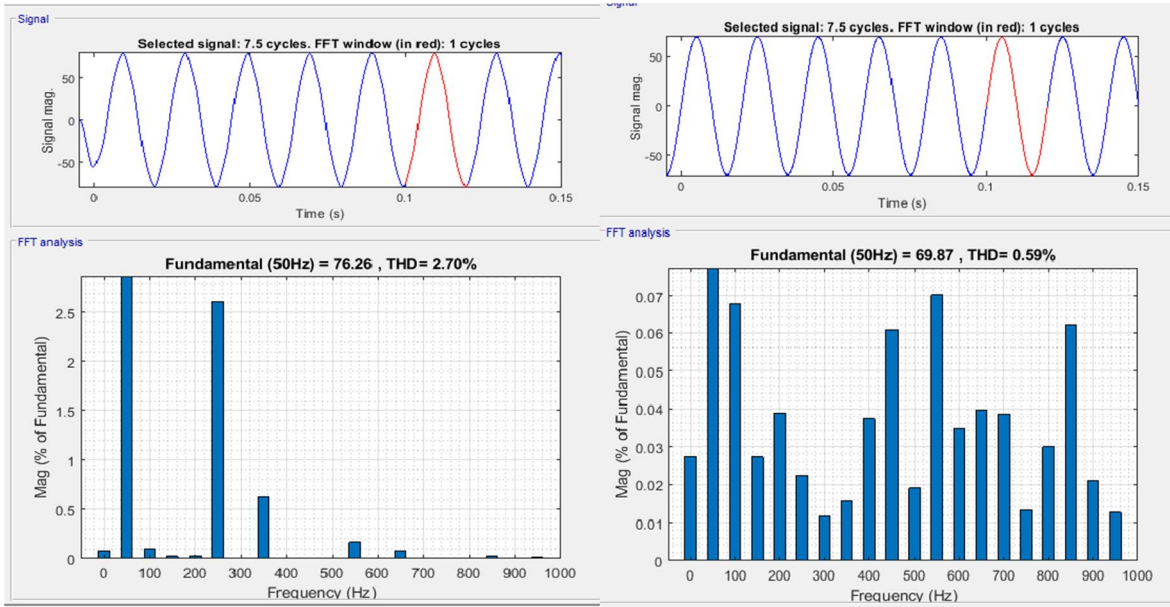

Load current at feeder 2

Source current at feeder 2

Fig. 10: FFT analysis Offeeder 1

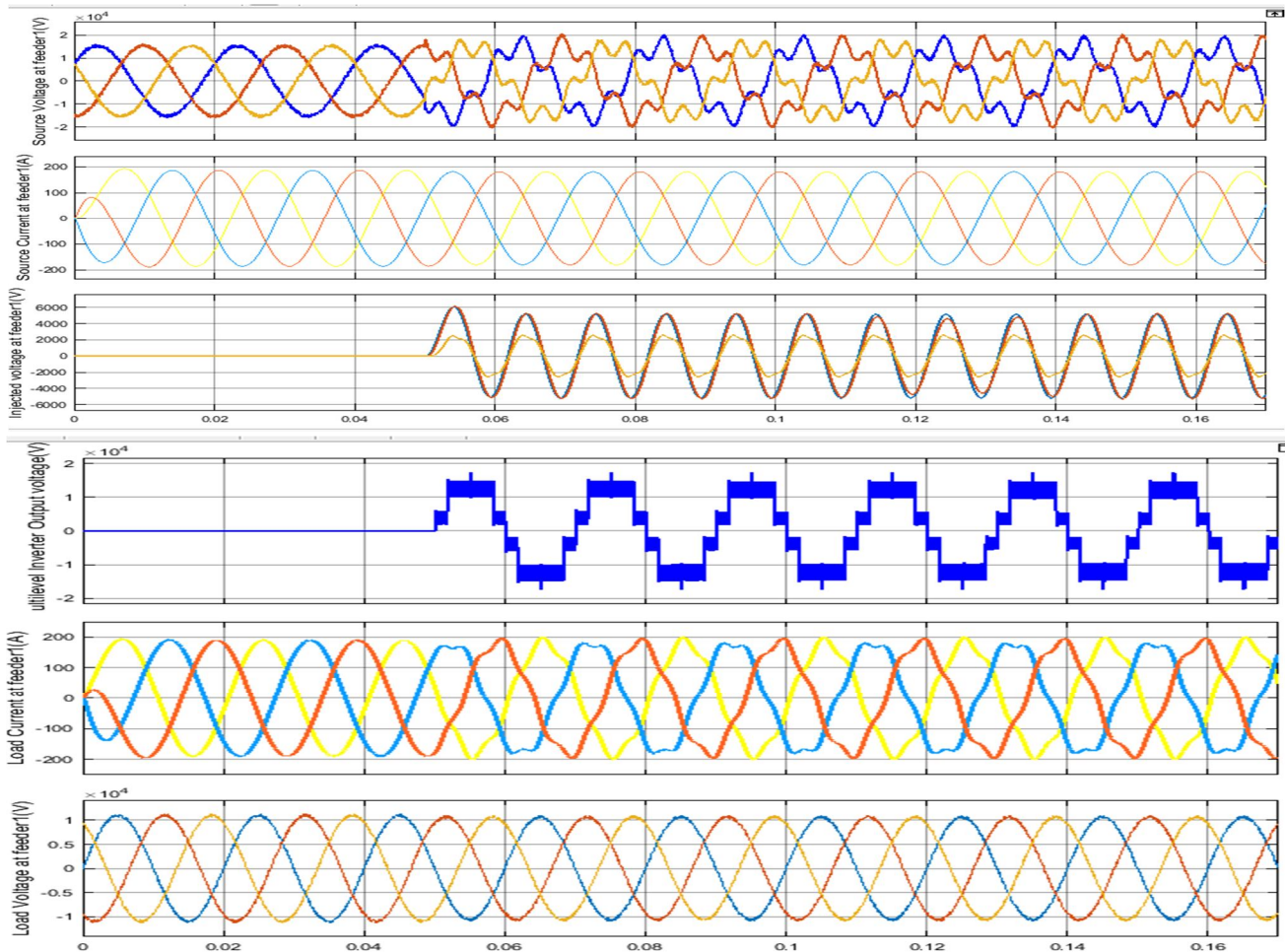

Fig. 11: Voltages and currents at feeder 1

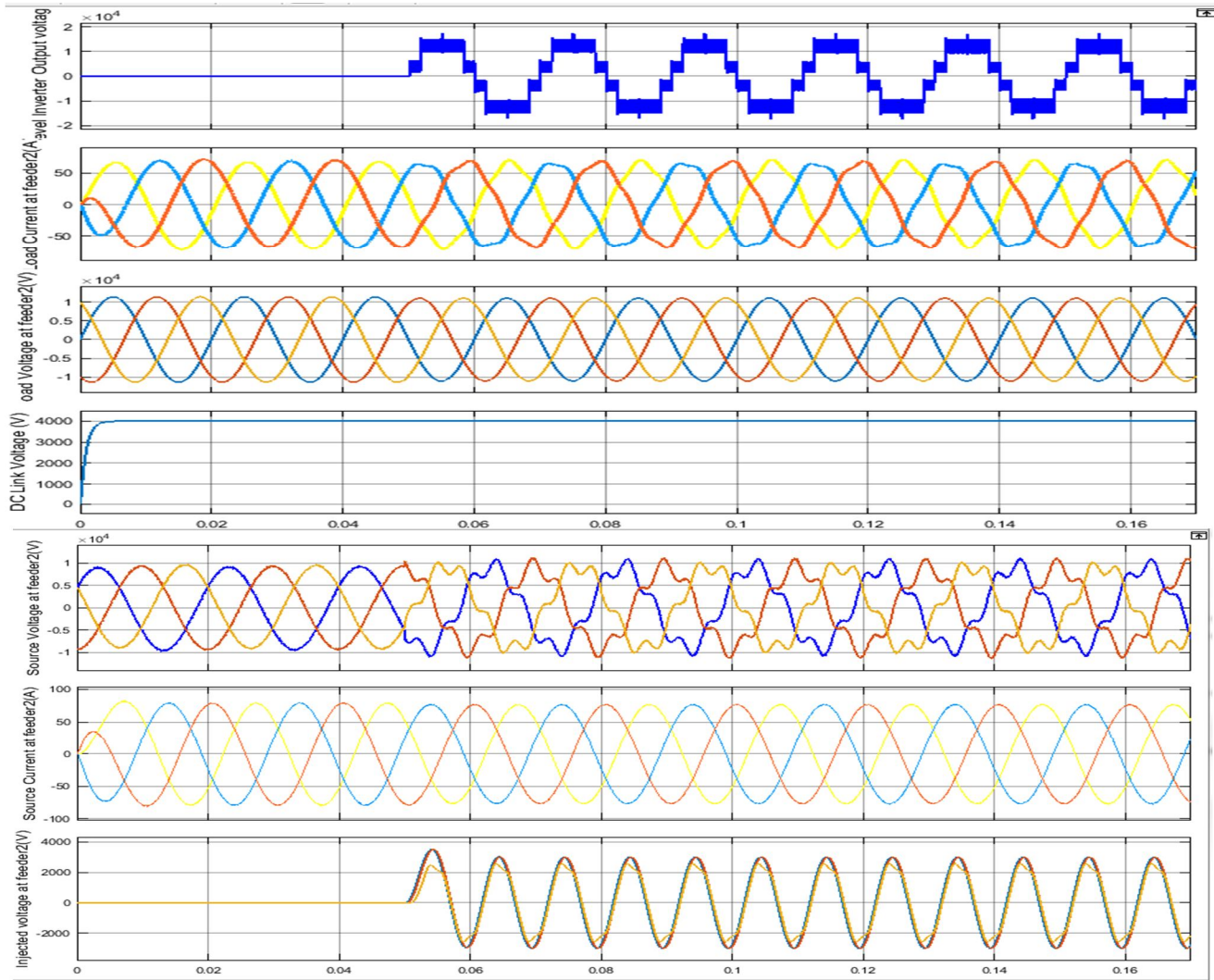

Fig.12: Voltages and currents at feeder 2

A multi-level converter (MLC) can be seen in Fig. 11 and Fig. 12 as a voltage source, as well as a current sink (spring current, load current, injected voltage). Figures 13 and 14 show the results of an FFT with respect to THD values. On the load side, the THD of Feeder 1 has decreased by 4.63% to 2.733%, while that of Feeder 2 has decreased by 2.59% to 0.073%.

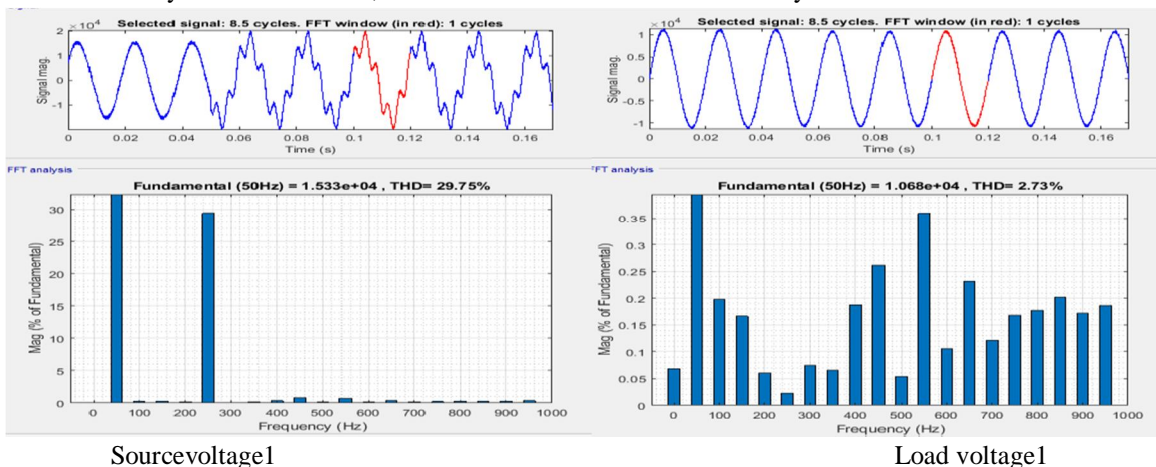

Fig.13: FFT analysis at feeder 1

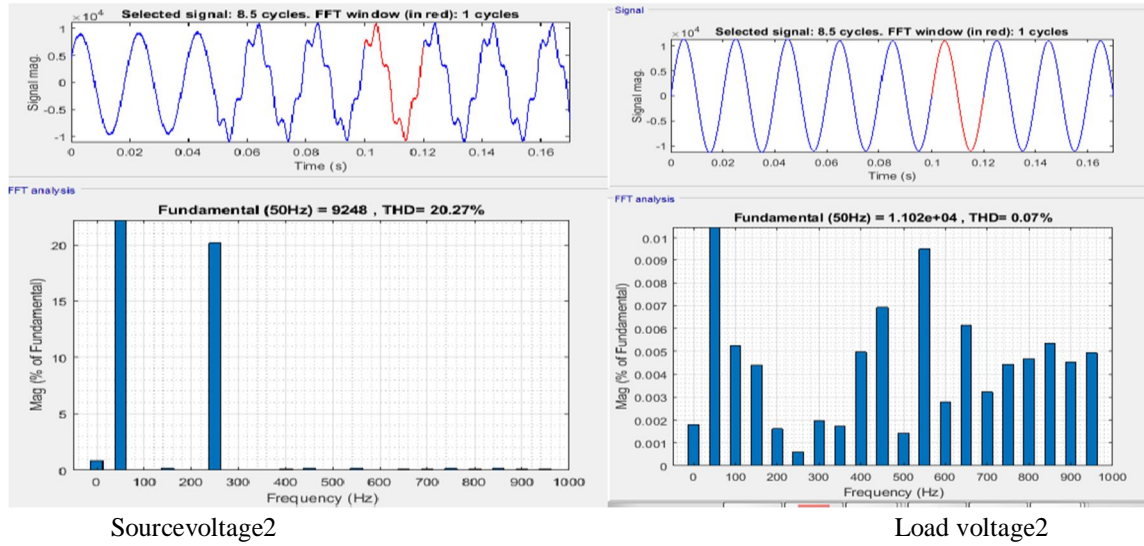

Fig 14: FFT analysis at feeder 2

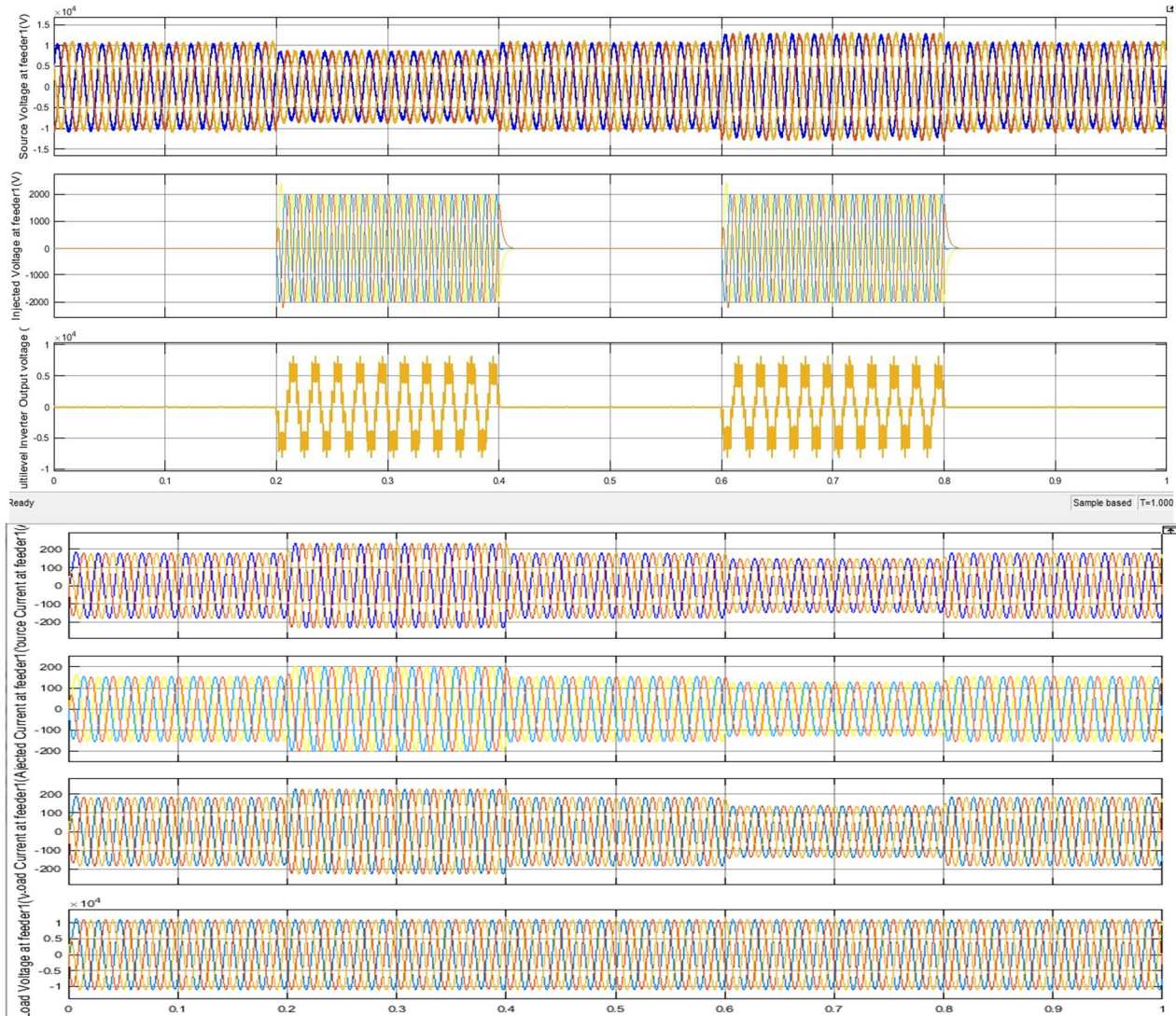

Fig 15: Voltages and currents at feeder 1

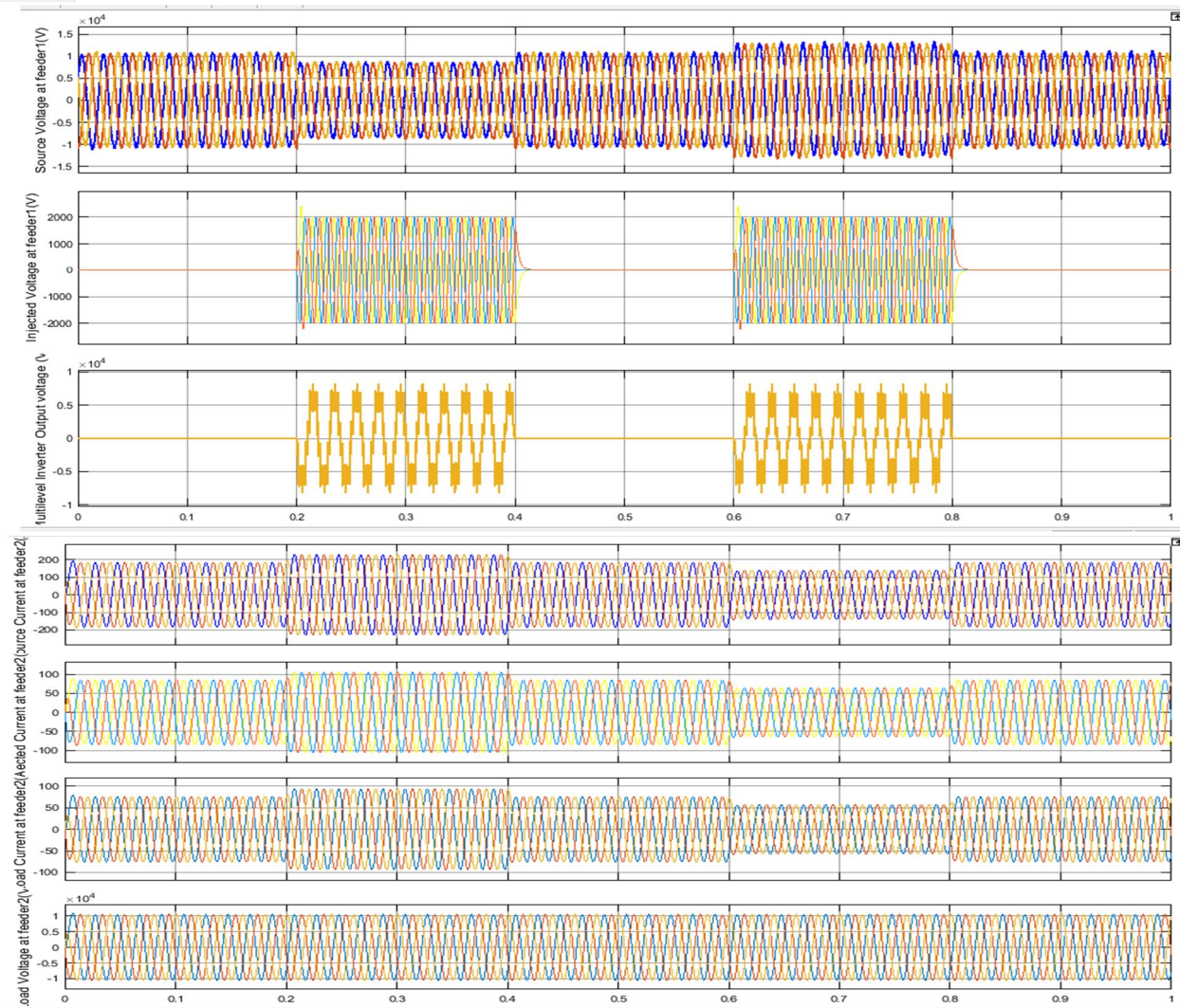

Fig.16: Voltages and currents at feeder 2

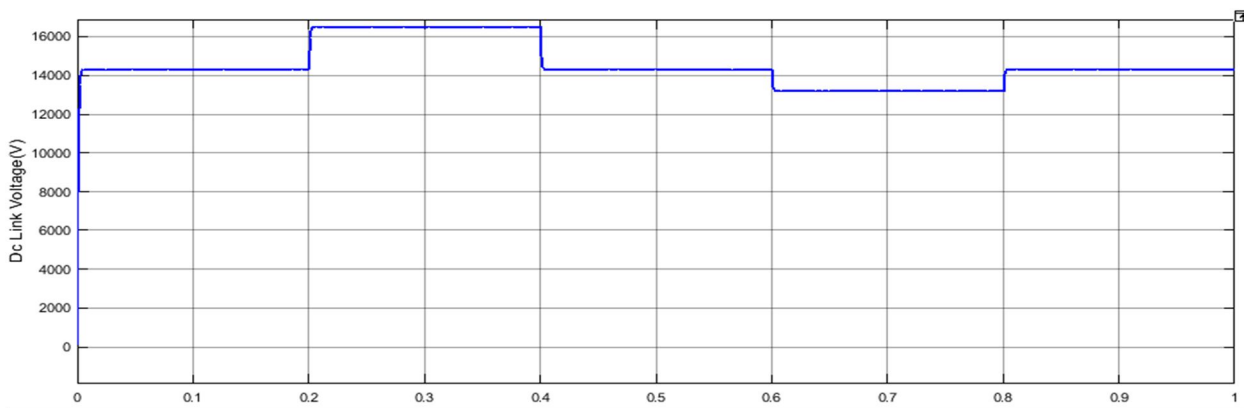

Fig.17: DC link voltage

It feeds 50mH and 100mH load to the first feeder and 100 and 140mH load to the second feeder. Figures 15 and 16 show the voltages and currents at the feeders' sources, loads, injected voltages, and multilevel converter volt ages. Source voltage compensation is visible at both feeder loads, as can be seen in the diagram. Figure 17 shows the voltage across the DC link capacitor. PSO is critical in lowering voltage regulation error while utilising a PI controller.

VI. CONCLUSION

The hybrid renewable energy system is built and implemented for several variations in the results demonstrate that the IUPQC may be satisfactorily applied for grid integration of HRES. In order to safeguard loads against tensile disturbances in the system, IUPQC is able to control load voltages. It also offsets the nonlinear load currents in reactive and harmonic components. For adjustment of Slope/swell and current voltage harmonics, power from healthy feeding to nearby feeders can be transferred. In multi-feeder systems, IUPQC can be a superior way of solving numerous power quality problems.

VII. FUTURE SCOPE

There will be less power semiconductor components in converters when new trends arise, lowering the cost of a converter. Additionally, new circuit configurations of HAPFS are constantly being developed to provide cost-effectiveness and improved performance in HAPFS. Using electric vehicles and a PV-integrated grid improves PQ. PV output fluctuations can be minimised by altering the way electric vehicles are charged. EV technology can significantly reduce distortions that impair PQ. A wide range of optimization approaches can help raise the quality of electric power.

REFERENCES

- [1] M. Rastogi, R. Naik, and N. Mohan, "A comparative evaluation of harmonic reduction techniques in three-phase utility interface of power electronic loads," in Proc. IEEE Ind. Appl. Conf. 28th IAS Annu. Meeting, Toronto, ON, Canada, Oct. 1993, pp.971–978.
- [2] H. Akagi, "New trends in active filters for power conditioning," IEEE Trans. Ind. Appl., vol. 32, no. 6, pp. 1312–1322, Nov/Dec.1996.
- [3] F. Z. Peng, "Application issues of active power filters," IEEE Ind. Appl. Mag., vol. 4, no. 5, pp. 21–30, Sep./Oct.1998.
- [4] H. Fujita and H. Akagi, "The unified power quality conditioner: The integration of series- active and shunt-active filters," IEEE Trans. Power Electron., vol. 13, no. 2, pp. 315–322, Mar.1998.
- [5] J. W. Dixon, G. Venegas, and L. A. Moran, "A series active power filter based on a sinusoidal current-controlled voltage-source inverter," IEEE Trans. Ind. Electron., vol. 44, no. 5, pp. 612– 620, Oct.1997.
- [6] V. Khadkikar, "Enhancing electric power quality using UPQC: A comprehensive overview," IEEE Trans. Power Electron., vol. 27, no. 5, pp. 2284–2297, May2012.
- [7] D. Vilathgamuwa, H. M. Wijekoon, and S. S. Choi, "A novel technique to compensate voltage sags in multilane distribution system the interline dynamic voltage restorer," IEEE Trans. Ind. Electron., vol. 53, no. 5, pp. 1603–1611, Oct.2006.
- [8] D. M. Vilathgamuwa, H. M. Wijekoon, and S. S. Choi, "Interline dynamic voltage restorer: A novel and economical approach for multilane power quality compensation," IEEE Trans. Ind. Appl., vol. 40, no. 6, pp. 1678–1685, Nov.2004.
- [9] A. K. Jindal, A. Ghosh, A. Joshi, and A. M. Gole, "Voltage regulation in parallel distribution feeders using IVOLCON," in Proc. IEEE Power Energy Soc. Gen. Meeting-Convers. Del. Electr. Energy 21st Century, Jul. 2008, pp.1–8.



10.22214/IJRASET



45.98



IMPACT FACTOR:
7.129



IMPACT FACTOR:
7.429



INTERNATIONAL JOURNAL FOR RESEARCH

IN APPLIED SCIENCE & ENGINEERING TECHNOLOGY

Call : 08813907089  (24*7 Support on Whatsapp)