



IJRASET

International Journal For Research in
Applied Science and Engineering Technology



INTERNATIONAL JOURNAL FOR RESEARCH

IN APPLIED SCIENCE & ENGINEERING TECHNOLOGY

Volume: 10 **Issue:** XII **Month of publication:** December 2022

DOI: <https://doi.org/10.22214/ijraset.2022.48103>

www.ijraset.com

Call:  08813907089

E-mail ID: ijraset@gmail.com

Steady and Transient Analysis of Engine Cylinder Head with Fins at 300⁰C and 500⁰C

Raushan Kumar¹, Vijaykant Pandey²

¹M-Tech Research Scholar, RKDF College of Technology, Bhopal (M.P.), India

²Assistant Professor, RKDF College of Technology, Bhopal (M.P.), India

Abstract: *The combustion chamber of a motor cycle's engine cylinder is subjected to high temperatures and thermal strains, on which fins are attached to cool the cylinder, and fins are given on the cylinder to boost the heat transfer rate. Thermal investigation of an engine block with fins was performed in this paper. The heat dissipation inside the cylinder may be determined by doing thermal analysis on cylinder block fins. The premise of cylinder block cooling is to extend the fins across the cylinder block, increasing the heat transfer rate. The engine block fins' parametric model was created in 3D software Solidworks, and thermal analysis was performed on the fins with grooves and fins without grooves with and without the block to determine temperature variation in transient and steady states, that is, with and without considering over time. ANSYS software is used for thermal analysis. Analysis is also performed on other materials. In this thesis report, two models were produced in software, and amended designs of the same model were studied, as well as a comparison of two models based on geometry and material.*

Keywords: *IC Engine, Fins, Engine performance, Efficiency, Heat Transfer, Thermal Analysis, Steady State Analysis.*

I. INTRODUCTION

The internal combustion engine is a type of engine in which a fuel is burned with an oxidizer (usually air) in a combustion chamber. The expansion of high-temperature and high-pressure gases produced by combustion gives direct force to a few components of an internal combustion engine, such as pistons, turbine blades, or a nozzle. This force propels the aspect forward, generating valuable mechanical electricity. Most modern-day internal combustion engines are cooled using a closed circuit of liquid coolant flowing through channels within the engine block, where the coolant absorbs warmth, to a warmth exchanger or radiator, where the coolant releases warmth into the air.

As a result, even though they are ultimately cooled by air, they are referred regarded as water-cooled due to the liquid-coolant circuit. In comparison, heat created by an air-cooled engine is released directly into the air. Typically, this is helped by metallic fins overlaid on the exterior of the cylinders, which increase the surface area on which air may act. In all combustion engines, a large proportion of the heat generated (approximately forty four%) leaves via the exhaust, not via a liquid cooling mechanism or the metallic fins of an air-cooled engine (12%). Approximately 8% of the heat electricity finds its way into the oil, which, while generally intended for lubrication, also plays a role in heat dissipation via a cooler. There are three types of heat transmission. The first is conduction, which is defined as heat transmission via a medium.

Without bulk motion of the substance, intervening should be counted. A stable has two floors, one at high and one at low temperatures. This type of heat conduction can occur in a jet engine, for example, through a turbine blade. The outside floor, which is exposed to gases from the combustor, is hotter than the inside floor, which has cooling air following it. Convection, or heat switch due to a flowing fluid, is the second heat transmission system. The fluid can be a gas or a liquid, and both have uses in aircraft generation. The warmth is transferred by bulk transfer of a non-uniform temperature fluid in a convection warmth switch. The 0.33 process involves the transport of electrical through space without the presence of matter. Radiation is the most effective heat switch technique in the area. Even when there is an intervening medium, radiation can be critical; a common example is heat transfer from a gleaming piece of metal or from a fireplace.

Convective heat transfer between surfaces and surrounding fluid can be improved by introducing slender strips of metallic known as fins. Extended surfaces are another name for fins. When available surfaces are insufficient to transmit the needed amount of heat, fins can be employed. Fins are synthetic and come in a variety of sizes and shapes depending on the use. Air cooling for an integrated circuit The engine is a well-known example of an air cooling system in which air serves as a medium. Heat generated in the cylinder can be dissipated into the environment via conduction mode via the fins or extended surfaces used in this device, which can be included around the cylinder.



Figure 1 [12]

II.LITERATURE REVIEW

Pulkit Agarwal etc. [1] simulated the heat transfer in motor cycle engine fan using CFD analysis. It is observed that ambient temperature reduces to the very low value; it results in over cooling and poor efficiency of the engine. They have concluded that over cooling also affects the engine efficiency

Magarajan U et.al. [2] have studied heat release of engine cylinder cooling fins with six numbers of fins having pitch of 10 mm and 20 mm, and are calculated numerically using commercially available CFD tool Ansys Fluent. The engine was at 150 C and the heat release from the cylinder was analyzed at a wind velocity of 0 km/h. Their CFD results were mostly same as that of the experimental results. So, they concluded that, it is possible to modify the fin geometry and predict those results, changes like tapered fins, providing slits and holes in fins geometry can be made and the optimization of fins can be done. A.K. Mishra et.al. [3] carried out transient numerical analysis with wall cylinder temperature of 423 K initially and the heat release from the cylinder is analyzed for zero wind velocity.

The heat release from the cylinder which is calculated numerically is validated with the experimental results. To increase the cylinder cooling, the cylinder should have a greater number of fins. However, the cylinder cooling may decrease with an increased number of fins and too narrow a fin pitch.

G. Babu and M. Lavakumar [4] analyzed the thermal properties by varying geometry, material and thickness of cylinder fins. The models were created by varying the geometry, rectangular, circular and curved shaped fins and also by varying thickness of the fins. Material used for manufacturing cylinder fin body was Aluminum Alloy 204 which has thermal conductivity of 110-150W/mk and also using Aluminum alloy 6061 and Magnesium alloy which have higher thermal conductivities. They concluded that by reducing the thickness and also by changing the shape of the fin to curve shaped, the weight of the fin body reduces thereby increasing the efficiency.

The weight of the fin body is reduced when Magnesium alloy is used and using circular fin, material Aluminum alloy 6061 and thickness of 2.5mm is better since heat transfer rate is more and using circular fins the heat lost is more, efficiency and effectiveness is also more. S.S.

Chandrakant et.al.[5] conducted experiments for rectangular and triangular fin profiles for air velocities ranging from 0 to 11 m/s. Experimental and CFD simulated result proves that annular fins with rectangular fin profiles are more suitable for heat transfer enhancement as compared to triangular fin profiles. Surface temperature of triangular fin profile is higher than rectangular fin profile at different air velocity. Heat transfer coefficient increase with increases with increases in velocity in both profiles. In comparison of both profile rectangular fin profile have higher heat transfer coefficient than triangular fin profile.

III. CFD

Computer primarily based simulation is mentioned during this chapter. procedure simulation is technique for examining fluid flow, heat transfer and connected phenomena like chemical reactions. This project uses CFD for analysis of flow and warmth transfer. CFD analysis accepted go in the various industries is employed in R&D and producing of craft, combustion engines and in powerhouse combustion similarly as in several industrial applications.

A. Why Computational Simulation

Three-dimensional (3D) numerical analysis of whorled coil tubes is dispensed by victimization business CFD tool ANSYS 18.2. this can become troublesome and time overwhelming, if this analysis is dispensed by experimentation.

Experimental setup is extremely expensive that's why in my work I take facilitate of CFD to create it easier and fewer time overwhelming.

B. Computational Fluid Dynamics

Computational fluid dynamics, because the name implies, could be a subject that deals with procedure approach to fluid dynamics by means that of a numerical resolution of the equations that cause the fluid flow and though it's known as procedure fluid dynamics; it doesn't simply wear down the equations of the fluid flow, it's conjointly generic enough to be ready to solve at the same time along the equations that direct the energy transfer and similarly the equations that verify the chemical process rates and the way the chemical process takings and mass transfer takes place; of these things may be tackled along in a regular format.

So, this define permits America to wear down a really complicated flow circumstances in fairly quick time, specified for a specific set of conditions, associate degree engineer would be ready to simulate and see however the flow is happening and what quite temperature distribution there's and what quite product area unit created and wherever they're fashioned, in order that {we can|we will|we area unit able to} build changes to the parameters that area unit below his management to switch the approach that these items are happening.

So, therein sense procedure fluid dynamics or CFD becomes a good tool for a designer for associate degree engineer. it's conjointly a good tool for associate degree associate degree analysis for associate degree examination of a reactor or an instrumentality that isn't functioning well as a result of in typical industrial applications, several things is also happening associate degreeed what a designer has had in mind at the time of fabricating or coming up with the instrumentality won't be really what an operator of the instrumentality introduces into the instrumentality at the time of operation, perhaps once 5 years or 10 years changes might need taken place in between; and in such a case, the presentation of the instrumentality won't be up to the quality and you'd wish to modify it in such some way that you just will restore performance.

So, the question is then, what this can managed to the autumn within the performance associate degreeed what quite measures we are able to build while not creating an overall adjustment within the finish of apparatus. Is it potential to urge improved performance from the equipment? Is it potential to extend the productivity? If you wish to appear on of these analysis, then procedure fluid dynamics is employed.

IV. METHODOLOGY

- 1) Stage 1: Aggregation data and information identified with cooling blades of IC motors.
- 2) Stage 2: An absolutely parametric model of the motor square with balance is made in Solidworks
- 3) Stage 3: Model got in Step an attempt of is investigated utilizing ANSYS 18.2 (Workbench), to get the warmth or warmth rate, warm angle and nodal temperatures.
- 4) Stage 4: Manual computations are finished.
- 5) Stage 5: Finally, we will in general will in general check the outcomes got from ANSYS 18.2 and manual calculations for totally unique material, shapes and thickness.

A. Transient Thermal Analysis

Transferring different temperatures after a while is desirable for some applications such as cooling electronic packages and final heat treatment inspection.

The temperature cycle is fascinating together, involving a hot load that can cause frustration. In such cases, temperatures from transient or unsteady thermal studies are used as a data source or used as initial test start conditions for thermo-baric valuation. Temporal hot probes are performed using ANSYS or Samcef problem solvers.

Intermittent hot testing is involved in many hot motion applications such as heat treatment issues, electronic package fashions and styles, fountains, motor squares, pressure vessels, and fluid structure related issues.

V. RESULTS

Engine Fins model geometry with aluminium alloy 6061

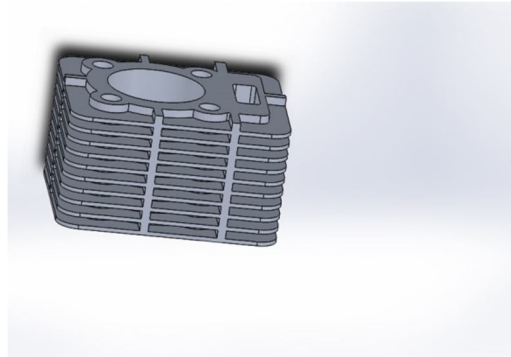

Fig. 2 Fins 3D solidworks model with aluminium alloy 6061

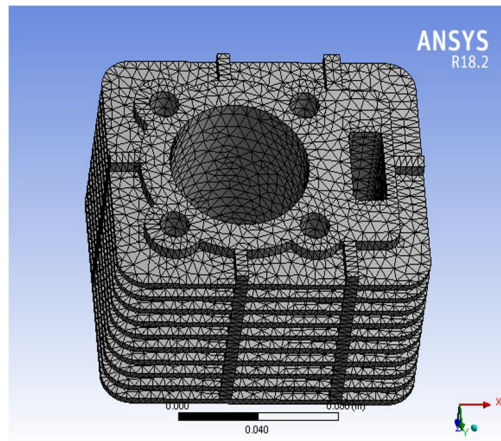

Fig.3 Fins meshing Al 6061 materials meshing

No. of Nodes	110096
Elements	60954

Table 1 : Meshing Statistics

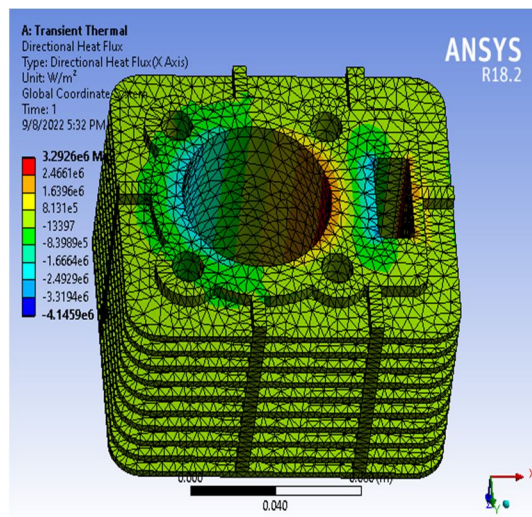

Fig.4 Fins Al 6061 materials directional heat flux transient at 300 °C

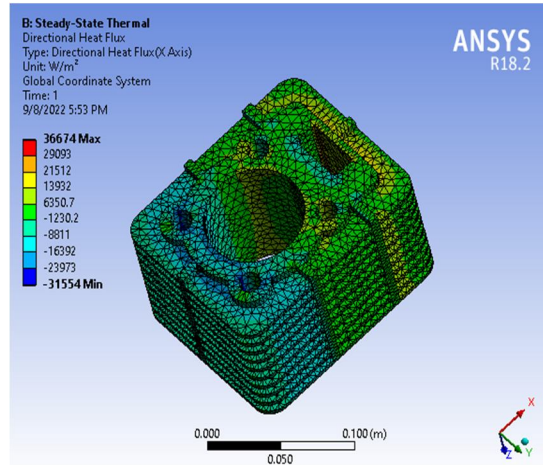

Fig.5 Fins Al 6061 Steady directional heat flux at 300⁰ C

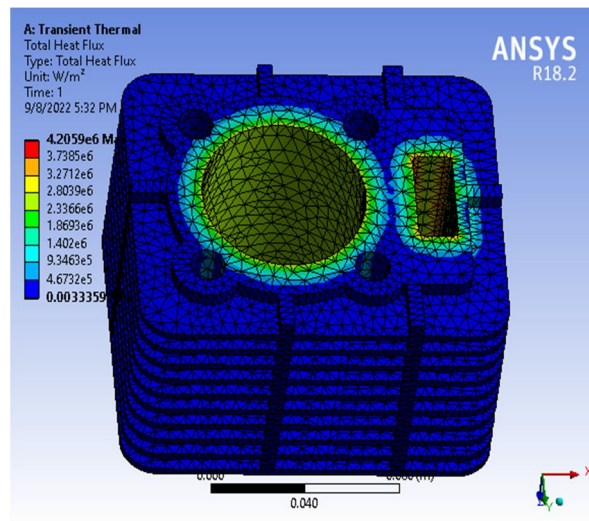

Fig.6 Fins Al 6061 materials total heat flux at 300⁰C transient

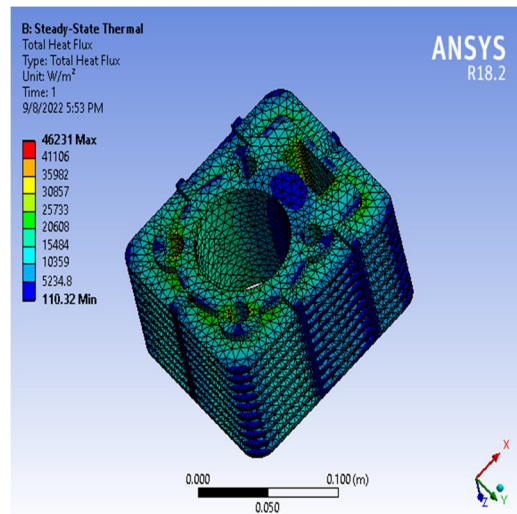

Fig. 7 : Fins Al 6061 materials total heat flux at 300⁰C steady

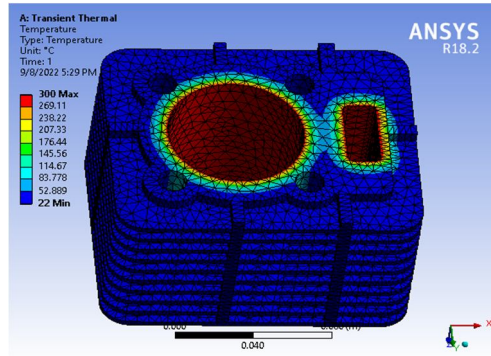

Fig. 8 : Fins Al 6061 materials temperature at 300°C transient

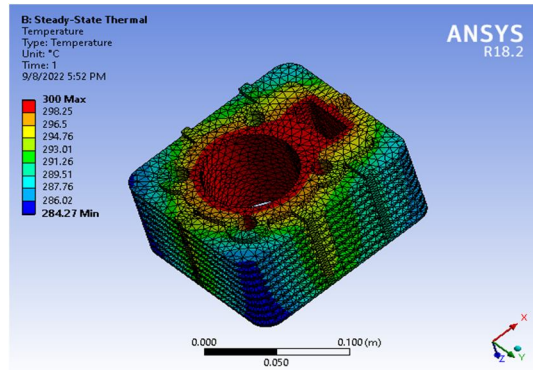

Fig 9 : Fins Al 6061 materials temperature at 300°C steady

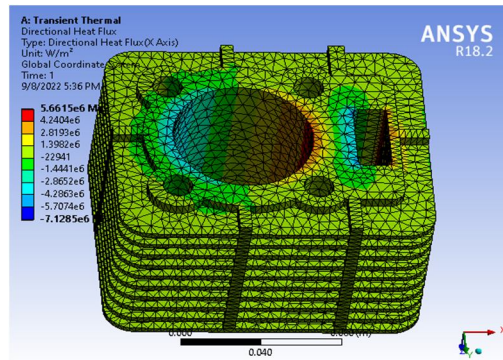

Fig. 10 Fins Al 6061 materials directional heat flux at 500°C transient

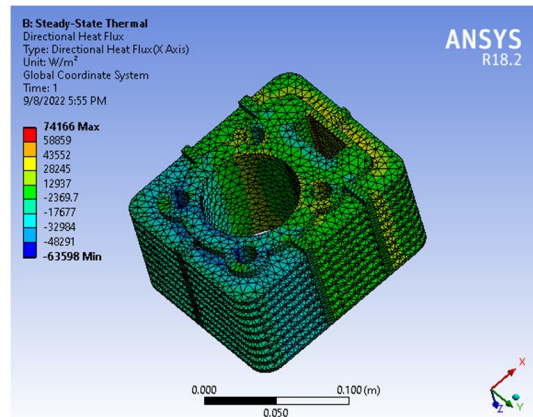

Fig. 11: Fins Al 6061 materials directional heat flux at 500°C steady

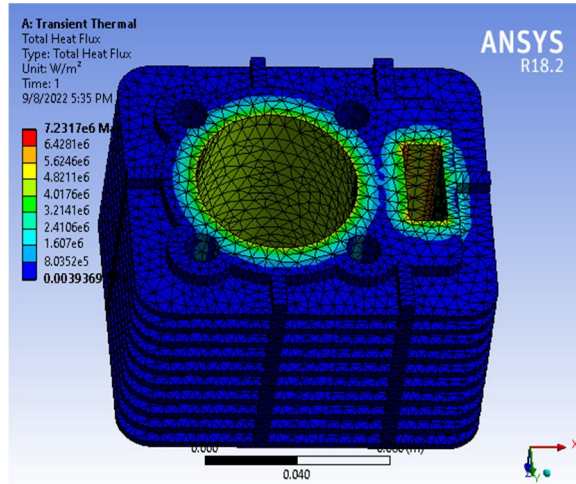

Fig. 12: Fins Al 6061 materials total heat flux at 500⁰C transient

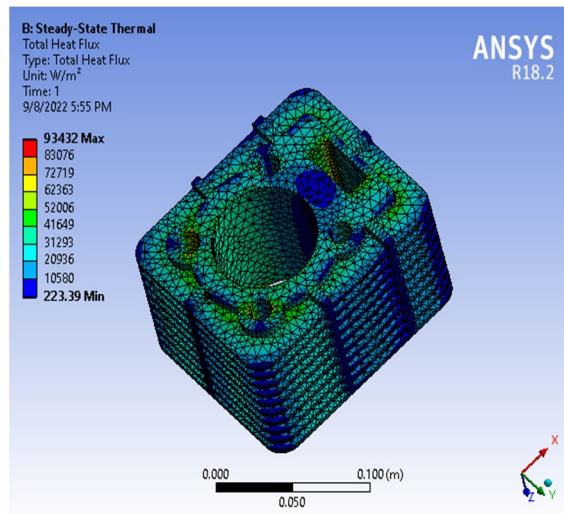

Fig. 13 : Fins Al 6061 materials total heat flux at 500⁰C steady

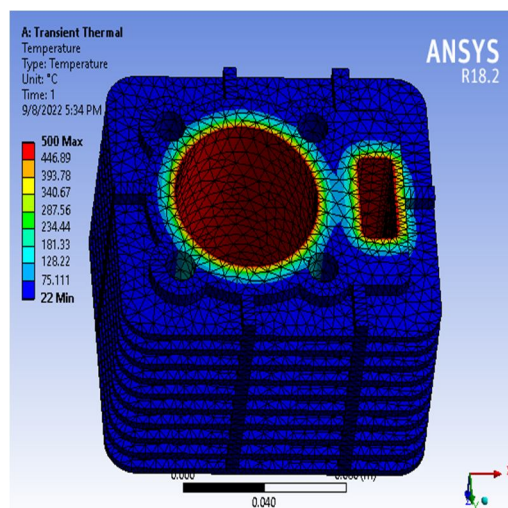

Fig. 14: Fins Al 6061 materials temperature at 500⁰C transient

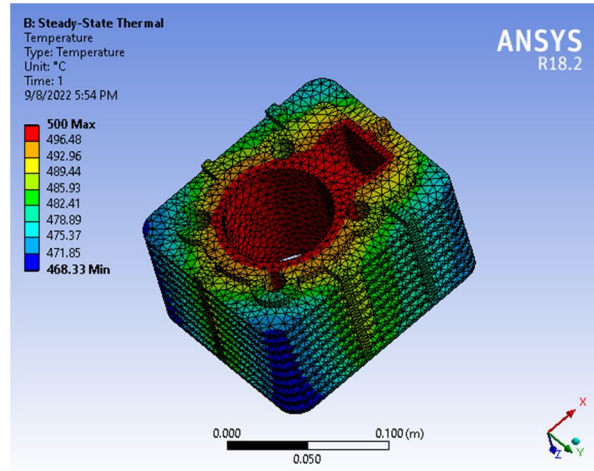

Fig. 15 : Fins Al 6061 materials temperature at 500⁰C steady

Table 1 Result Analysis

Temperature given to an engine head	Steady Directional heat flux (W/m ²)	Transient Directional Heat flux (W/m ²)	Steady Total Heat flux (W/m ²)	Transient Total Heat Flux (W/m ²)	Steady Temperature (°C)	Transient Temperature (°C)
At 300 °C	13932	3.2 * 10 ⁶	46231	4.2 * 10 ⁶	299.8	298.9
At 500 °C	28245	4.2 * 10 ⁶	52006	4.8*10 ⁶	499.1	498.9

VI. RESULT & DISCUSSION

An ad hoc worm research tool built with ANSYS Workbench R 18.2 and a logic programming framework improved a restricted number of experiments. Actual and predicted transient normalised convective heat transfer rates from each engine type, based on grouped major geometric characteristics. The fins of the engine housing head are briefly examined for heating at internal temperatures of 300 oC and 500 °C for enhanced geometrical parameters and extended heat transmission from the IC engine.

It does a transient heating test in a real-world setting with an ambient temperature of 40°C.

The geometry at 300°C and 500°C for aluminium 6061 exhibits total temperatures of 298.90°C and 498.90°C in transient and 299.80°C and 499.10°C in steady state.

VII. CONCLUSION

Using the 100cc Hero Honda Cruiser engine head model and the Solidworks 3D screen-planning framework software package, and balance body materials to the internal balance center of amalgam and dark cast iron, this white paper compiled a set of housing geometry for the engine head. I used aluminum 6061 with rectangular shape at 300°C and 500°C.

REFERENCES

- [1] Pudiri Madhu and N. Sateesh., An experimental investigation into the Modeling and Simulation of Fins for 150cc Engine, SAE paper (2015)R. Caves, Multinational Enterprise and Economic Analysis, Cambridge University Press, Cambridge, 1982. International Journal of Recent Development in Engineering and Technology Website: www.ijrdet.com (ISSN 2347-6435(Online) Volume 5, Issue 6, June 2016) 36
- [2] D. Merwin Rajesh and K Suresh Design and thermal analysis of cylinder fins by varying its geometry and material, IJME International Journal, ISSN NO: 2348- 4845 (2014)
- [3] Thornhill D. and May A., An Experimental Investigation into the Cooling of Finned Metal Cylinders in a free Air Stream, SAE Paper 1999-01-3307 (1999)
- [4] Gibson H., The Air Cooling of Petrol Engines, Proceedings of the Institute of Automobile Engineers, Vol.XIV, 243-275 (1920)
- [5] Biermann E. and Pintel B., Heat Transfer from Finned Metal Cylinders in an Air Stream, NACA Report No. 488 (1935)
- [6] Masao Yoshida, Soichi Ishihara, Yoshio Murakami, Kohei Nakashima and Masago Yamamoto, Air-Cooling Effects of Fins on Motorcycle Engine, JSME International Journal, Series B, 49(3), (2006)
- [7] Zakhirhusen, Memon K., Sundararajan T., Lakshminarasimhan V., Babu Y.R. and Harne Vinay, Parametric study of finned heat transfer for Air Cooled Motorcycle Engine, SAE Paper, 2005-26-361. (2005)
- [8] Zakirhusen, Memon K. and Sundararajan T., Indian Institute of Technology Madras, V. Lakshminarasimhan, Y.R. Babu and Vinay Harne, TVS Motor Company Limited, Simulation and Experimental Evaluation of Air Cooling for Motorcycle Engine, 2006-32-0099 / 20066599 (2006)



- [9] Pathak Sunil, Turbo charging and oil techniques in light motor vehicles, Res.J. Recent Sci, 1(1), 60-65 (2012)
- [10] Dev Nikhil, Attri Rajesh, Mittal Vijay, Kumar Sandeep, Mohit, Satyapal, Kumar pardeep, Thermodynamic analysis of a combined heat and power system, Res.J. Recent Sci, 1(3), 76-79 (2012)
- [11] G.Raju, et al. (2012). "Optimal Design of an I.C. Engine Cylinder Fin Arrays Using a Binary Coded Genetic Algorithms." International Journal of Modern Engineering Research (IJMER) 2(6): 4516-4520.
- [12] U. Magarajan, et al. (2012). "Numerical Study on Heat Transfer of Internal Combustion Engine Cooling by Extended Fins Using CFD." International Science Congress Association 1(6): 32-37.
- [13] A. Mishra, et al. (2012). "Heat Transfer Augmentation of Air Cooled Internal Combustion Engine Using Fins through Numerical Techniques." Research Journal of Engineering Sciences ISSN 2278:9472.
- [14] J.A. Paul, et al. (2012). "Experimental and Parametric Study of Extended Fins in the Optimization of Internal Combustion Engine Cooling Using CFD." International Journal of Applied Research in Mechanical Engineering (IJARME) 2(1).
- [15] G. Babu and M. Lavakumar (2013). "Heat Transfer Analysis and Optimization of Engine Cylinder Fins of Varying Geometry and Material." IOSR Journal of Mechanical and Civil Engineering (IOSR-JMCE) 7(4): 24-29.
- [16] S.S.Chandrakant, et al. (2013). "Numerical and Experimental Analysis of Heat Transfer through Various Types of Fin Profiles by Forced Convection." International Journal of Engineering Research & Technology (IJERT) 2(7).
- [17] A.R. Kumar, et al. (2013). "Heat Transfer Analysis in the Cylinder Head of a Four-Stroke SI Engine." International Journal of Engineering Research & Technology (IJERT) 2(5).
- [18] R.P. Patil and P. H. M. Dange (2013). "Experimental and Computational Fluid Dynamics Heat Transfer Analysis on Elliptical Fin by Forced Convection." International Journal of Engineering Research & Technology (IJERT) 2(8).
- [19] N.P.R. Rao and T. V. Vardhan (2013). "Thermal Analysis of Engine Cylinder Fins By Varying Its Geometry and Material." International Journal of Engineering 2(8).
- [20] S. Wange and R. Metkar (2013). "Computational Analysis of Inverted Notched Fin Arrays Dissipating Heat by Natural Convection." International Journal of Engineering and Innovative Technology (IJEIT) 2(11).
- [21] V. GANESAN, (2008). I C Engines, McGraw-Hill Education (India) PVT Limited.



10.22214/IJRASET



45.98



IMPACT FACTOR:
7.129



IMPACT FACTOR:
7.429



INTERNATIONAL JOURNAL FOR RESEARCH

IN APPLIED SCIENCE & ENGINEERING TECHNOLOGY

Call : 08813907089  (24*7 Support on Whatsapp)