



# IJRASET

International Journal For Research in  
Applied Science and Engineering Technology



---

# INTERNATIONAL JOURNAL FOR RESEARCH

IN APPLIED SCIENCE & ENGINEERING TECHNOLOGY

---

**Volume: 9      Issue: XI      Month of publication: November 2021**

**DOI: <https://doi.org/10.22214/ijraset.2021.38978>**

**[www.ijraset.com](http://www.ijraset.com)**

**Call:  08813907089**

**E-mail ID: [ijraset@gmail.com](mailto:ijraset@gmail.com)**

# Thermal Overload Protection and Monitoring using Programming Logic and Sensor Technology

Sanna Tariq<sup>1</sup>, Masarat Majid<sup>2</sup>, Subia Ashraf<sup>3</sup>, Mr. Shahid Mohi Ud Din<sup>4</sup>

<sup>1, 2, 3</sup>B.E Students, <sup>4</sup>Assistant Professor, Department of Computer Science and Engineering, SSM College of Engineering, Kashmir, India

**Abstract:** Transformers are the main building block in a power system. Any damages in transformers adversely affects the balance of a power system. The damages are mainly occurring due to overloading and inefficient cooling. The main objective of the project is real time monitoring of the health conditions of the distribution transformer. The parameters such as temperature, current, voltage, oil temperature, oil height, transformer temperature etc. of a transformer are monitored, processed and recorded in the servers. The recorded data can be send using Wi-Fi module and accessed from anywhere around the world using IOT technology using HTTP protocol. This helps in identifying without human dependency. This helps in identifying and solving a problem before a failure without human dependency. The system also includes the thermal over load and automatic shut down protection of transformer.

**Keywords:** Realtime Monitoring, Health condition, Wi-Fi module, IOT Technology, HTTP protocol.

## I. INTRODUCTION

The distribution transformer directly provides the low voltage users with power supply. Thus, the working condition of the transformer plays an important role in distribution network. The transformers must be operated in rated condition for their long life. This is not possible during entire working periods. Overloading and deficient cooling of transformers can cause unexpected failure in transformers which can disturb delivering of electricity over many consumers. The manual checkup of rise in voltage, rise in ambient temperature, load current etc. tends to be more complex as incidental parameters cannot be accessed [1]. In IoT, interaction between the physical and digital worlds using sensors and actuators are carried out. A sensor or a network of sensors are used to sense the physical parameters or the respective environment. These processed sensor output are then send to the main server or cloud with the help of various network devices. The data can be accessed over internet from anywhere around the world. Monitoring and controlling form the basic objective of IoT technology. Hence IoT based monitoring is preferred more than manual monitoring. The system is a real time monitoring of transformer parameters such as voltage, current and temperature.

## II. TRANSFORMER FAULT ANALYSIS

A power transformer consists of a set of windings around a magnetic core. The windings are insulated from each other and the core. Operational stresses can cause failure of the transformer winding, insulation, and core. The power transformer windings and magnetic core are subject to a number of different forces during operation:

- 1) Expansion and contraction caused by thermal cycling
- 2) Vibration caused by flux in the core changing direction
- 3) Localized heating caused by eddy currents in parts of the winding, induced by magnetic flux.
- 4) Impact forces caused by fault currents.
- 5) Thermal heating caused by overloading.

These operating limits only considered the thermal effects of transformer overload. Later, the capability limit was changed to include the mechanical effect of higher fault currents through the transformer. Power transformer faults produce physical forces that cause insulation wear. These effects are cumulative and should be considered over the life of the transformer. The following discussion highlights on different capability limits of transformer.

### III. LITERATURE SURVEY

#### A. Faults In Transformers

The major faults occurring in a transformer are overload, over / under voltage, temperature rise, oil level fault etc.

- 1) **Overload / Overcurrent:** Overload / Overcurrent is the flow of fault current occurring in the power system through the transformer. These condition last for a short duration of about or less than 2 seconds as protection relays isolate the power system.
  - 2) **Over / Under Voltage:** Over voltage results when voltage to frequency ratio exceeds 1.05 pu at full load and 1.10 pu during no load condition.
  - 3) **Temperature Rise:** Transformers are generally designed to work for 24 hours with an average ambient temperature of 300 C. Over voltage and over current causes an increase of oil temperature which induce failure of insulation of transformer winding.
  - 4) **Oil Level Fault:** Oil present in transformers provides cooling and insulation. Temperature could reduce the oil level and its reduction beyond a required level affects cooling and insulation.
- a) **OverLoad/OverCurrent:** OverLoad /Overcurrent is the current flowing through the transformer resulting from faults on the power system. Fault currents that do not include ground are generally in excess of four times full-load current; fault currents that include ground can be below the full-load current depending on the system grounding method. Over current conditions are typically short in duration (less than two seconds) because protection relays usually operate to isolate the faults from the power system. Overload, by contrast, is current drawn by load, a load current in excess of the transformer nameplate rating. In summary, loading large power transformers beyond nameplate ratings can result in reduced dielectric integrity, thermal runaway condition (extreme case) of the contacts of the tap changer, and reduced mechanical strength in insulation of conductors and the transformer structure. Three factors, namely water, oxygen, and heat, determine the insulation life of a transformer. Filters and other oil preservation systems control the water and oxygen content in the insulation, but heat is essentially a function of the ambient temperature and the load current. Current increases the hottest-spot temperature (and the oil temperature), and thereby decreases the insulation life span.
  - b) **Temperature:** Excessive load current alone may not result in damage to the transformer if the absolute temperature of the windings and transformer oil remains within specified limits. Transformer ratings are based on a 24-hour average ambient temperature of 30°C (86°F). Due to over voltage and over current, temperature of oil increases which causes failure of insulation of transformer winding.
  - c) **Over/Under Voltage:** The flux in the transformer core is directly proportional to the applied voltage and inversely proportional to the frequency. Over voltage can occur when the per-unit ratio of voltage to frequency (Volts/Hz) exceeds 1.05 p .u at full load and 1.10 p .u. at no load. An increase in transformer terminal voltage or a decrease in frequency will result in an increase in the flux. Over excitation results in excess flux, which causes transformer heating and increases exciting current, noise, and vibration.
  - d) **Oil Level Fault:** Oil mainly used in transformer for two purposes one is for cooling of transformer and another use is for insulation purpose. When temperature of transformer goes high, oil level in transformer tank decreases due to heating effect. For normal operation of transformer oil level should maintain at required level. If oil level decreases beyond required level, it affect cooling and insulation of the transformer.

### IV. METHODOLOGY

The main objective of the proposed project is to acquire real-time data of transformer remotely over the internet falling under the category of Internet of Things (IOT). For this real-time aspect, we take one temperature sensor, one potential transformer and one current transformer for monitoring T, V, I data of the transformer and then send them to a remote location.

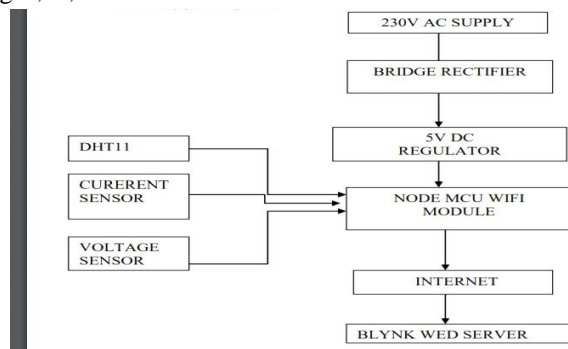

### V. FACILITIES REQUIRED FOR PROPOSED WORK

#### A. Hardware Used

- 1) ESP 12e
- 2) Acs712
- 3) DIODES, CAPICATORS, VOLTAGE REGULATORS
- 4) STEP DOWN TRANSFORMER
- 5) Ds18b20
- 6) Sonar
- 7) Dht/lm

#### B. Software Used

- 1) Arduino IDE Compiler
- 2) IOT Web Server

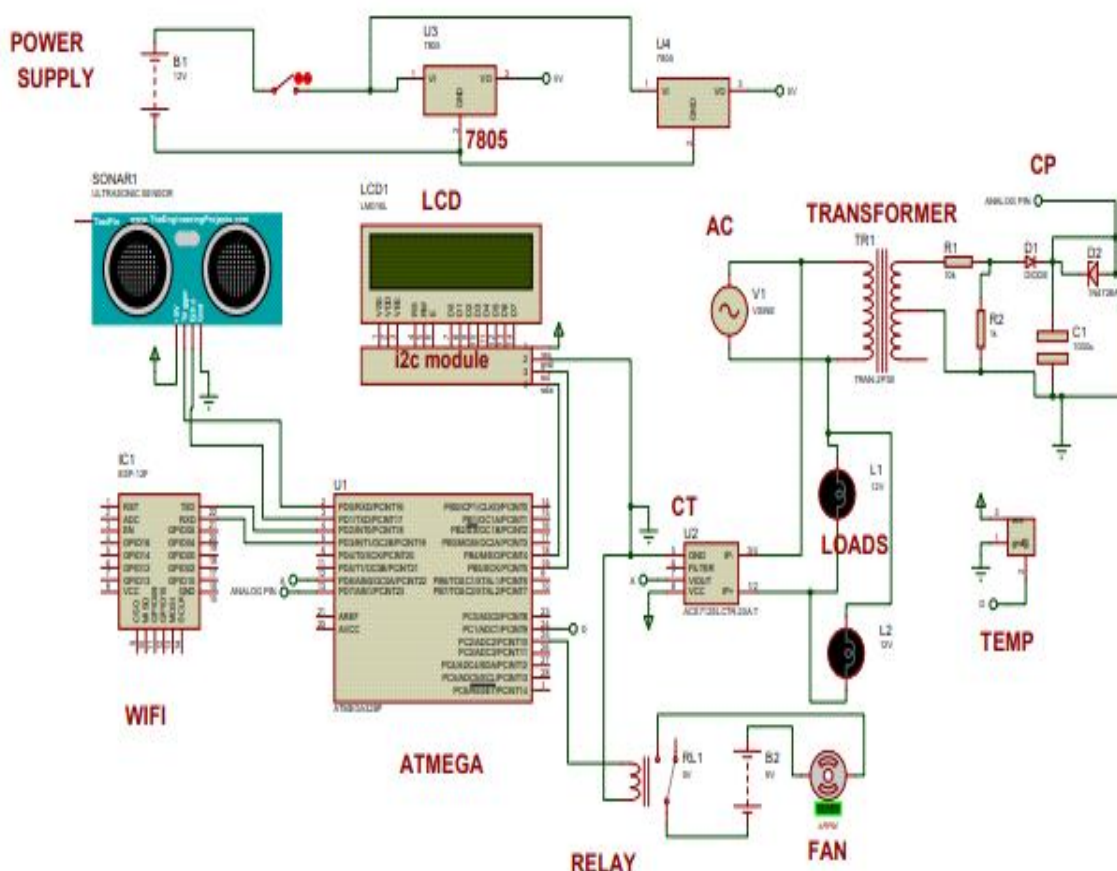

### VI. CONCLUSION

The transformers play a vital role in distribution part of power system. Therefore the monitoring and protection of transformer is very crucial. This system introduces a new and improved method of transformer health parameter monitoring using IoT. The sensors incorporated in the system collect the data of transformer health parameters such as voltage, temperature and current. These data can be sent and accessed using HTTP protocol. Thus the real time data collection, storage and monitoring of the transformer health parameters are possible with the system.



#### VII. ACKNOWLEDGEMENT

We take this opportunity to express our profound sense of gratitude and respect to all those who helped us throughout the duration of this project. We acknowledge the effort of those who have contributed significantly to our project. First of all we are very thankful to our God for providing us such a great opportunity to do the Project in this college and also very thankful to our parents for their regular support and guidance. We feel privileged to offer our sincere thanks and deep sense of gratitude to DR. SAJAD HUSSAIN DIN, MRS. YASMEEN and Mr. SHAHID Mohi Ud Din for expressing their confidence in us by letting us work on a project of this magnitude and using latest technologies and providing their support, help & encouragement in implementing this project. Last but not the least, we are grateful to all our friends for providing critical feedback & support whenever required. There are times in such projects when clock beats you time and you run out of energy, you just want to finish it once and forever, Parents and Friends made us endure such times with their unfailing humor & warm wishes.

#### REFERENCES

- [1] Abdul-Rahman AI-Ali, Abdul Khaliq & Muhammad Arshad "GSM Based Distribution Transformer Monitoring System," IEEE MELECON 2004, May 12-15, 2004, Dubrovnik, Croatia.
- [2] K. Sridhar, M. Assarudeen, J. Ranjith Kumar, E. Sarathbabu "Transformer Health Monitoring And Control Through Arduino," IJAERD – International Journal of Advanced Engineering and Research, vol. 5, Issue 04, 2018.
- [3] Monika Agarwal, Akshaypandya, "GSM Based Condition Monitoring of Transformer," IJSRD - International Journal for Scientific Research & Development, Vol. 1, Issue 12, 2014, ISSN (online): 2321-0613.



10.22214/IJRASET



45.98



IMPACT FACTOR:  
7.129



IMPACT FACTOR:  
7.429



# INTERNATIONAL JOURNAL FOR RESEARCH

IN APPLIED SCIENCE & ENGINEERING TECHNOLOGY

Call : 08813907089  (24\*7 Support on Whatsapp)