



# IJRASET

International Journal For Research in  
Applied Science and Engineering Technology



---

# INTERNATIONAL JOURNAL FOR RESEARCH

IN APPLIED SCIENCE & ENGINEERING TECHNOLOGY

---

**Volume:** 11    **Issue:** IV    **Month of publication:** April 2023

**DOI:** <https://doi.org/10.22214/ijraset.2023.50108>

[www.ijraset.com](http://www.ijraset.com)

Call:  08813907089

E-mail ID: [ijraset@gmail.com](mailto:ijraset@gmail.com)

# Transformation of Sound Energy into Electrical Energy Using IoT

B. S. Jubedha<sup>1</sup>, K.V. Siva Prasad Reddy<sup>2</sup>, B.Varshitha<sup>3</sup>, G. Raga Chandrika<sup>4</sup>, N. Chandra Teja<sup>5</sup>

<sup>1, 2, 3, 4, 5</sup> CSE Department, JNTUACEP, Pulivendula, AP, India

**Abstract:** *The world is expanding more and more rapidly and we have a lot of energy in bondage. Energy is in distinct forms i.e noise energy, electrical energy, mechanical energy, etc. Energy cannot be generated or demolished but it can be transformed from one energy formation into further. However, we are rapidly expanding and finding a solution to this situation. Now a days noise energy is considered one of the biggest problems in big cities and it cannot be controlled or reduced but they can be used as energy resources. And this noise energy can be used to bring about energy. Factories, industries, vehicles, airports, etc. cause a lot of sound energy. We modify this sound energy into electrical energy. Now a days, Electrical energy source play a foremost role. So, we require additional electrical energy as world population increasing rapidly, especially renewable resources, pure and clean energy sources. Non-renewable energy sources are in short supply. So, we need to utilise the renewable energy resource very carefully. And one of the main mottos of this project is the produced electrical energy is used to reduce the accidents in the deep curve hill station areas by detecting the vehicles. And also, we can use this produced electrical energy in street lights. This project describes work done on conversion techniques and methods used to convert noise energy to corresponding electrical energy.*

**Keywords:** *Noise energy, Electrical energy, Internet of Things, renewable resources, non-renewable resources, Arduino UNO, Energy conversion, Sound Buzzer, LDR sensor, UV sensor, Transformer step up.*

## I. INTRODUCTION

Consistent with the "Law of Energy Transformation", it declares that energy cannot be produced or demolished, but can be transfigured from one formation to further [1][10]. Putting in this law of energy conversion, the IOT technology is used to transform sound energy into electrical energy.

Electrical energy is a tangential energy source and electrical energy is neither a renewable nor a non-renewable resource[5]. It is extracted from first energy sources such as wind, natural gas, solar and coal. In India, the electrical energy sector is firstly produced from the fossil fuels.

According to the reports India is won's third ranked in the world for the production and usage of the electrical energy. In this 21st century, power in our society is very pervasive and corrupt. Can you visualize life without you Computers, mobile phones, lamps, etc. Everyday device, it's really very important. We can't visualize our life without these devices and all the devices we need to operate. As the world's population increases, power consumption is also increasing. India's electrical energy use increased by 13.31% on an annualized basis to 1273900 crore units in the month of September 2022.

Sound energy is the type of energy that living beings can take in. Sound energy produced by the vehicles, airports, railway stations and industries/ factories are going wasted. But this sound energy can used to convert into electrical energy. Renewable resources are natural resources that grow through natural regeneration or other iterative processes in a finite amount of time on the human timescale to replace the parts that have been depleted through avail and utilization [1]. Renewable resources include energy from biomass, hydroelectric power, geothermal energy, wind energy and solar energy. A non-renewable useful resource is a real useful resource that can't get replaced through real manner rapid sufficient to preserve up with consumption [1]. Non-renewable assets consist of oil, herbal gas, coal and nuclear power.

## II. LITERATURE REVIEW

With the help of IOT devices we are transformation of sound energy into electrical energy. Sound Buzzer is used as input devices where it converts sound signals into electrical signals and it is normally electrified by DC voltage. And the output of sound buzzer is given as input to the transformer step up and it will transform low level voltage from the first side of the transformer to a high-level voltage on the tangential side of the transformer.

An abstract published by research gate published by International Research Journal of Engineering and Technology states Generating of electricity from sound pollution. Abstract states the generation of electricity from sound pollution. sound is major issue in big cities, etc. but the utilization of this sound energy in the right way to transform this sound pollution into electricity. And to use this electrical energy for everyday purposes. And the "Law of Energy Transformation", it declares that energy cannot be produced or demolished, but can be transfigured from one formation to further.

Ref.No	Authors	Title	Description
[9]	Alankrit Gupta, Vivek Goel, Vivek Yadav	Conversion of Sound to Electric Energy	This paper describes work done on conversion approach and systems used to transform acoustic energy into corresponding electricity. It focuses on feasibility and its application to ground zero. Method 1: Faraday's Law for Electromagnetic Induction Method 2: Lead zirconate titanate, barium titanate, and zinc oxide are used as piezoelectric materials.
[8]	M.Viknesh, S.Vinoth, M.Maheswaran, P.Sivasakthy	Generation of electrical energy from sound energy	This paper states that "GENERATION OF ELECTRICAL ENERGY FROM SOUND ENERGY". Sound is known for pushing the technical side of things at a faster pace than ever before. However, the use of technology in various fields is very low. It is well known that urban noise pollution increases with traffic volume. Here we propose a system that uses sound sensors to collect sound signals and uses the received waves to generate electrical energy.
[11]	Mrs. Vinu, S.Rajabharath, R.Samuel Kamalanathan, P.Pravin Abraham, T.Sampaul Billygram	Generation of electricity from sound energy	We used a piezoelectric transducer that captures the acoustic signal and converts it into equivalent electrical energy. The output of the piezo plate is sent to an ADC for analog-to-digital conversion and sent to a microcontroller to monitor the value of energy produced. The output of the converter is also fed to the boost controller. The resulting energy is amplified in the boost controller and passed to the DC-DC converter. The output of the DC-DC converter is saved in memory. The stored energy is converted to alternating voltage and fed to relays to be used for other purposes such as lighting lamps.
[5]	Shalabh Rakesh Bhatnagar	Converting sound energy to electric energy	Sound is a form of energy that travels in the form of waves, mechanical waves. This is pressure oscillation. This pressure produced by sound can be used to transformation it into electricity or other forms of energy.
[4]	Varsha Jaware, Partibha Gautam, Rohit Mar, Anup Panday, Nikul Sindhav	Conversion of electricity from the sound energy (noise pollution)	This article presents how sound is transformed to electricity by many conversions from wind, solar, biogas and many other forms of energy to electrical energy. However, this paper focuses on the energy from sound to electricity. We are surrounded by sound energy in any street we are conscious of, whether it is a street, an airport, a highway or a street.

### III. PROJECTED SYSTEM

The projected system comprises of a sound buzzer i.e electromagnetic buzzer. The electromagnetic buzzer converts the sound signal into electrical energy. Then a transformer step-up transforms a low-level voltage from the first side of the transformer to a high-level voltage on the tangential side of the transformer.

#### A. Block Sketch

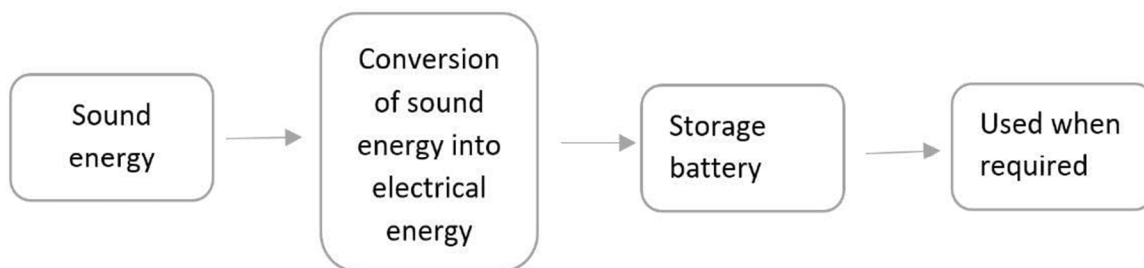

Fig 1: Block sketch of projected system

In the block sketch above, Figure 1 shows how our project works. Here, sound energy is given as input to the IOT devices then it will transform it into the electrical energy. Once electrical energy is produced it will be stored in batteries and that electrical energy can be used where ever and whenever it is required.

#### B. Circuit Diagram

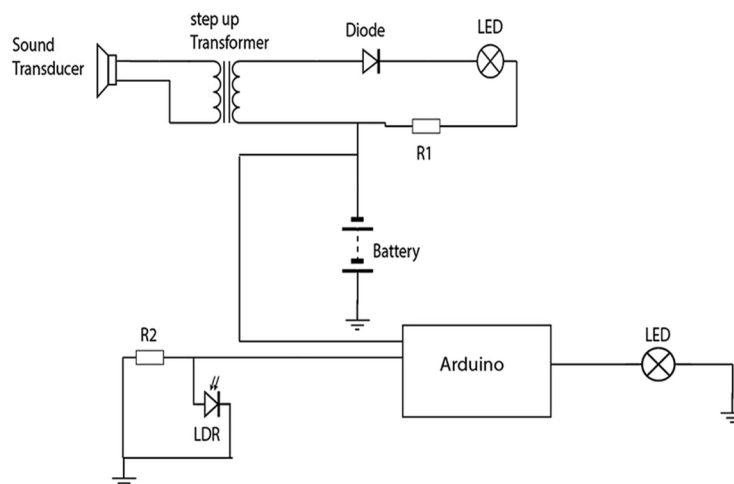

Fig 2: Circuit Diagram

In the above circuit diagram contains Arduino UNO, electromagnetic buzzer, transformer step up, LDR and UV sensor. The generated electrical energy used in automatically switching street lights and in accidents detection in deep curve hill stations.

### IV. METHODOLOGY

Generating electrical energy from sound energy using IOT devices. IOT devices are electromagnetic buzzer, LDR sensor, UV sensor, Arduino UNO and Transformer step up. When the audio signal is sent as input to the electromagnetic buzzer it converts the audio signal into sound signals/ sound waves. Then sound waves are sent as input to the transformer step up and it converts the sound waves into electrical energy.



**A. Electromagnetic Buzzer**

A buzzer is an acoustic tool that can transform sound signals into electrical energy. It normally operates on DC voltage. An electromagnetic buzzer consists of an oscillator, solenoid coil, magnet, diaphragm, case, etc. When the energy is given to become on, the audio signal cutting-edge generated with the aid of using the oscillator flows via the electromagnetic coil, producing a magnetic field. The diaphragm vibrates periodically below the interplay of magnetic coils and magnets to generate electric energy. A typical electromagnetic buzzer has a frequency of 2-4 kHz.



Fig 3: Electromagnetic Buzzer

**B. Transformer Step Up**

A step-up transformer is a type of transformer that transforms a low-level voltage from the first side of the transformer to a high-level voltage on the tangential side of the transformer. A transformer is a static electrical device that transforms electrical energy (from the windings on the primary side) into magnetic energy (in the magnetic core of the transformer) and back into electrical energy (the secondary side of the transformer). Step-up transformers have a variety of uses in electrical systems.

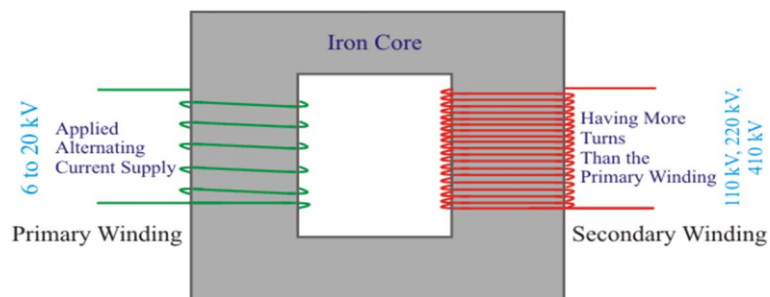

Fig 4: Transformer Step Up

**V. IMPLEMENTATION DIAGRAM**

Implementation of “Transformation of sound energy into electrical energy” and this system can be implemented in the city sound pollution is high. In smart cities all the appliances are running on the electrical energy by using this system we can generate electrical energy from the sound energy where sound energy is major problem.

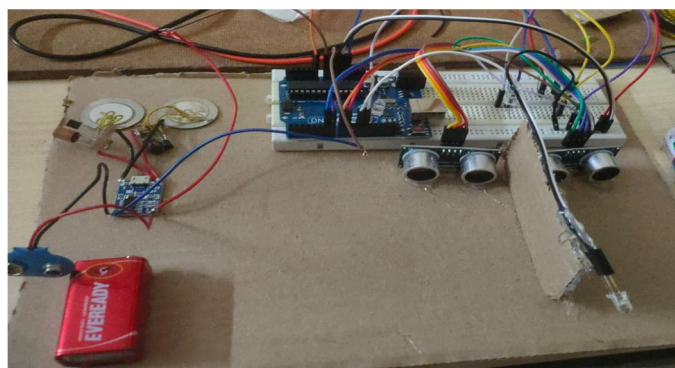

Fig 5: Implementation diagram

## VI. APPLICATIONS

The electrical energy produced from the transformation of sound energy is stored in the batteries and utilized when it is needed. The two applications of this project are.

### A. Automatically Switching Street Lights

You may have observed that some street lights that are automatically get switched on in the night and switched off automatically when it is morning. This happens because the street lights have photoresistor or light dependent resistor that work based on the sensitive of the light. In this project our application is to switch the street lights automatically. Here we are using the electrical energy generated from sound energy produced from the various resources.

An auto-switching street light circuit can basically be planned using an LDR sensor. The LDR sensor is used to detect the existence of ambient light, automatically turning off the street lights during the day when the sun is bright and automatically turning on the street lights at night when there is no light. The LDR sensor is the microcontroller that turns on the street lights.

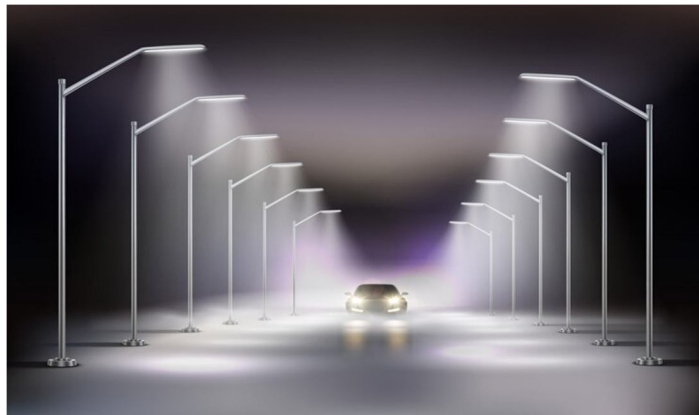

Fig 6: Automatically switching street lights

### B. Accidents Detection in Deep Curve Hill Stations

At the mountain curve, two masts are installed at the end of the curve. Each pole has an ultrasonic sensor attached. An ultrasonic sensor detects vehicles approaching the mast and sends information to the Arduino UNO control board. Each pin connected to the Arduino UNO control board has a warning signal. The Arduino UNO will programmatically turn on a warning light when the vehicle is approaching a curve on a slope. An Arduino microcontroller is connected to two ultrasonic sensors. The Arduino is programmed to determine the vehicle's distance at specified time intervals. From the change in vehicle spacing with time interval. By calculating and comparing the time it takes to reach the left and right runways, the warning LED lights up brightly to prevent accidents with oncoming vehicles. Electrical energy is supplied to the above components such as ultrasonic sensors, warning signals and microcontrollers. Ultrasonic sensors, which consume less power than other sensors such as infrared and magnetometer sensors, provide highly accurate and desirable results.



Fig 7: Accidents detection in deep curve hill stations

## VII. FUTURE SCOPE

This project is cost effective and easy to install. Airports, highways, industries intersection having high scope of the sound energy and these areas will provide place for this device to produce electrical energy. They can utilize the whenever there is required. This project can reduce the lack of electrical energy in the future [2]. The availability of such energy in the future will revolutionize the field of renewable energy. Overcoming the lack of electrical energy by developing new energy sources such as sound energy. And applications of this project are lightning of the street lights automatically when it is dark at the nights based on the light intensity-based sensor. And the other application is reducing accidents in deep curve hill station by detecting vehicles on the either side of the curve by using object detection sensor.

## VIII. RESULT

By using this system i.e “Transformation of sound energy into electrical energy” we can generate the electrical energy up to 6v to 8v. in this system we used the electromagnetic buzzer (sound buzzer) as an input device.

## IX. CONCLUSION & FUTURE SCOPE

Sound energy is an undetermined source great possible to encounter the extending commands of the future Works as electricity and environmentally friendly and renewable energy source [8]. This technology has not been put to practical use. Efficiency is a concern, but current work in this area makes sense Its future is bright.

Transformation of sound energy into electrical energy can be achieved in many ways but in this paper, we converting using IOT technology. Producing electrical energy from sound energy produced by the industries, airports and vehicles.

In future the scope of the project is to implement this system using combination of the input devices like sound buzzers, speakers and micro phone. In that case the generated voltage might be high. If we use micro phone as an input device then this system can be installed everywhere where sound energy is the major problem.

## REFERENCES

- [1] K. Kusuma Kumari et.al “Conversion of sound energy to electrical energy” – International Journal of Creative Research Thoughts (IJCRT). ISSN:2320-2882.
- [2] Neha Joshi, Dishant Kumar, Divam Chaudhary and Vinod Mishra “Study of conversion of sound energy into electrical energy” – International Journal on Emerging Technologies. ISSN:0965-8364.
- [3] Ajay Shyamkunwar, Ashis Patra, Tarun Shrivastava “Conversion sound (noise) energy into electrical energy” – International Journal of Innovative Research in Electrical, Electronics, Instrumentation and Control Engineering. ISSN:2321-2004.
- [4] Varsha Jawar et.al “Conversion of noise energy into electrical energy” - International Journal of Innovative Science and Research Technology. ISSN:2456-2165.
- [5] Shalabh Rakesh Bhatnagar “Converting sound energy to electrical energy” - International Journal of Engineering Technology and Advanced Engineering. ISSN:2250-2459.
- [6] Rizwan Ali Ansari “Conversion of electricity from the sound energy (noise pollution)” – ISERD International Conference, Dubai, UAE.
- [7] Satvik Sawhney et.al “Converting sound energy to electricity” - International Journal of Technical Research & Science. ISSN:2454-2024.
- [8] M. Viknesh, S.Vinoth, M.Maheswaram, P. Sivasakthy “Generating of electrical energy from sound energy” - International Journal of Engineering and Technology. ISSN:2395-0056.
- [9] Alankrit Gupta, Vivek Goel, Vivek Yadav “Conversion of sound to electric energy” - International Journal of Scientific & Engineering Research. ISSN:2229-5518.
- [10] Mohana Faroug Saeed Attia, Afraa Ibhraheim Mohammed Adbalateef “Evolution of electric energy generation from sound energy using piezoelectric actuator” - International Journal of Science and Research. ISSN:2139-7064.
- [11] Mrs. Vinu et.al “Generation of electricity from sound energy” - International Journal of Advanced Research Trends in Engineering and Technology. ISSN:2394-3777.
- [12] G. R. Ahmed Jamal\* et.al “Generation of Usable Electric Power from Available Random Sound Energy”.
- [13] Yasser A. Farghaly, Fahd Abdel Aziz Hemeida, Sahar Salah “Noise utilization as an approach for reducing energy consumption in street lighting”.
- [14] Pulkit Tomar et.al “CONVERSION OF NOISE POLLUTION TO ELECTRICAL ENERGY”. International Journal of Advanced Research in Science and Engineering. ISSN:2319-8354.
- [15] Mehul Garg et.al ” Generation of Electrical Energy from Sound Energy”.
- [16] Vishal V. Tambe et.al “Electric Power Generation using Random Sound Energy”, ISSN:2321-0605.
- [17] Mr. Sankalp Shrivastava et.al “CONVERTING SOUND ENERGY INTO ELECTRICITY USING PIEZOELECTRIC MATERIAL: A STUDY”. IISN:0976-6359.
- [18] Fitria Hidayanti, Erna Kusuma Wait, Hamid Akbar “Energy Harvesting System Design for Converting Noise into Electricity Energy”. IISN: 2005-4238.
- [19] Surjay Boral et.al “ENERGY HARVESTING USING SOUND ENERGY”. ISBN:978-93-5396-81-9.
- [20] Mr. R. Srinivasan et.al “Conversion of Sound Energy Into Electrical Energy”. ISSN:2581-9429.
- [21] Mohammed Ovaiz et.al “Generation of Electricity from Industrial Noise”. p-ISSN: 2395-0072.



#### **AUTHOR'S BIOGRAPHY**

B .S. Jubedha is pursuing B.Tech, Department of Computer Science and Engineering in Jawaharlal Nehru Technological University, Pulivendula, Kadapa District, Andhra Pradesh, India. Her main areas of Interest are in Data Mining, Machine Learning, Artificial Intelligence, Structured Query Language(SQL), Database Management System(DBMS) and Internet of Things(IoT).

K. V. Siva Prasad Reddy, Assistant Professor (Adhoc), Department of Computer Science and Engineering in Jawaharlal Nehru Technological University, Pulivendula, Kadapa District, Andhra Pradesh, India. His main areas of Interest are in Big Data, Machine Learning, Artificial Intelligence, Cloud Computing and Data Mining.

B. Varshitha is pursuing B.Tech, Department of Computer Science and Engineering in Jawaharlal Nehru Technological University, Pulivendula, Kadapa District, Andhra Pradesh, India. Her main areas of Interest are in Full stack Development , Machine Learning..

G. Ragachandrika is pursuing B.Tech, Department of Computer Science and Engineering in Jawaharlal Nehru Technological University, Pulivendula, Kadapa District, Andhra Pradesh, India. Her main areas of Interest are in Data science, Machine Learning.

N. Chandra Teja is pursuing B.Tech, Department of Computer Science and Engineering in Jawaharlal Nehru Technological University, Pulivendula, Kadapa District, Andhra Pradesh, India. His main areas of Interest are in SQL, Machine Learning, Database Management System(DBMS).





10.22214/IJRASET



45.98



IMPACT FACTOR:  
7.129



IMPACT FACTOR:  
7.429



# INTERNATIONAL JOURNAL FOR RESEARCH

IN APPLIED SCIENCE & ENGINEERING TECHNOLOGY

Call : 08813907089  (24\*7 Support on Whatsapp)