



IJRASET

International Journal For Research in
Applied Science and Engineering Technology



INTERNATIONAL JOURNAL FOR RESEARCH

IN APPLIED SCIENCE & ENGINEERING TECHNOLOGY

Volume: 11 **Issue:** V **Month of publication:** May 2023

DOI: <https://doi.org/10.22214/ijraset.2023.51687>

www.ijraset.com

Call:  08813907089

E-mail ID: ijraset@gmail.com

Use of Optimism Software to Observe Effect of Different Sources in Optical Fiber

Pratik Tawde¹, Servesh Gupta²

¹Electronics and Telecommunication Department, ²Information Technology Department, Vidyalankar Polytechnic, Wadala, India

Abstract: Attenuation in fiber optics also known as transmission loss is the reduction in intensity of light beamwidth request respect to distance travelled through a transmission medium. Attenuation coefficient in fiber optics usually use units of db /km. The medium is typically fiber of silica glass that confines the incident light beam to the inside Attenuation in optical fiber is caused primarily by both scattering and absorption

Keywords: optisim software, optical fiber, line codes.

I. INTRODUCTION

The output of semiconductor LASER exhibits fluctuation in its intensity, phase, frequency even when the LASER is biased at constant current with negligible current fluctuation. The two fundamental noise mechanisms are spontaneous and electron hole recombination. The occurrence rate of such a spontaneously emitted random field is about 10^{12} because of which intensity and phase of emitted light exhibit fluctuation over time scale as short as loops.

Intensity fluctuation lead to limited signal to noise ratio (SNR) whereas phase fluctuation leads to finite spectral width when semiconductor LASER are operated at constant current. Clearly such fluctuation lead to degradation of such system performance, so it is important to estimate their magnitude. Amplitude fluctuation are characterized by a factor called as relative Intensity to noise ratio. Self phase modulation is an important effect of light matter interaction. An ultrashort pulse of light when travelling in the medium will induce varying refractive index of medium due to kerr effect. This variation in refractive index will produce leading to change of pulse frequency spectrum. Self phase modulation is an important effect in optical system that in short pulse of light such as LASER in optical fiber communication.

A. NRZ and RZ Signal format

NRZ(Non return to zero) code is the simplest method for encoding data.Unipolar NRZ means that a logic1 is represented by voltage or light pulse that fills an entire bit percode,where as for logic0 Or no pulse is transmitted.

The NRZ code needs the minimum bandwidth and it is simple to generate and decode however the lack of being capalities is an NRZ code can lead to true miniinterpolation of bit stream at the receiver.

RZ (Return to zero) code method shows the tuning problem associated with NRZ encoding method.RZ method is used when inadequate bandwidth margin exists.

RZ code has amplitude transition at the beginning of each bit interval when binary 1 is beginning and each bit interval when binary 0. Thus for RZ pulse ,1 bit occupys only part of the bit interval and returns to zero in the remainder of bit interval no pulse is used for '0' bit.Although RZ pulse remain occupys exactly half a bit and send data at rate of 10Gb/sec and higher.

II. SIMULATION AND RESULTS

A. Effect of Source (Using Soliton Optical Pulse Generator optical Source)

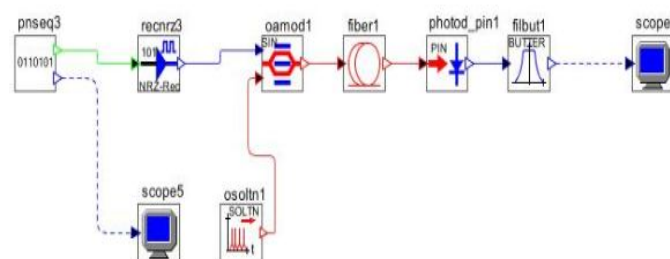

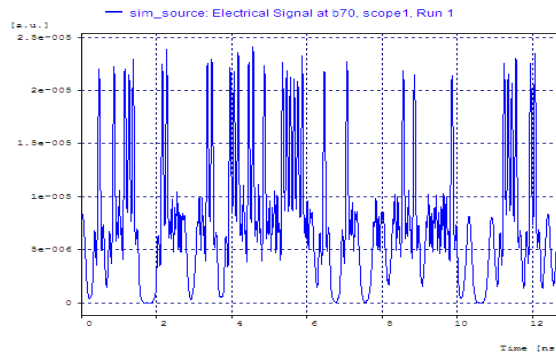
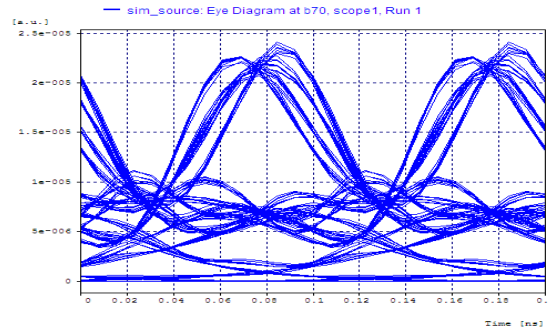

Lenth=100 Km

Q factor	6.0206
BER	0.0227501
Eye Closure	10.172178
Jitter	0.020811

B. Effect of Source (Using CW Lorentzian Laser optical source)

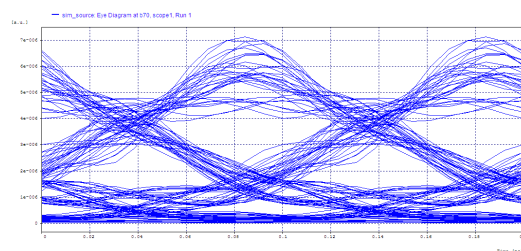
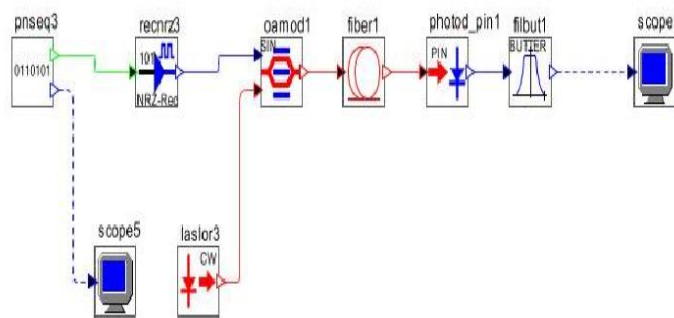

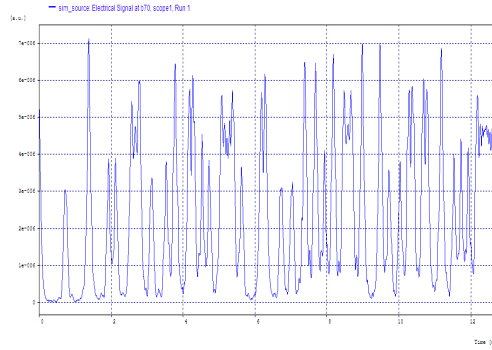

Lenth=100 Km

Q factor (dB)	12.128744
BER	3.82873e-005
Eye Closure (dB)	13.257768
Jitter (ns)	0.255276

C. Pulse Generator Input

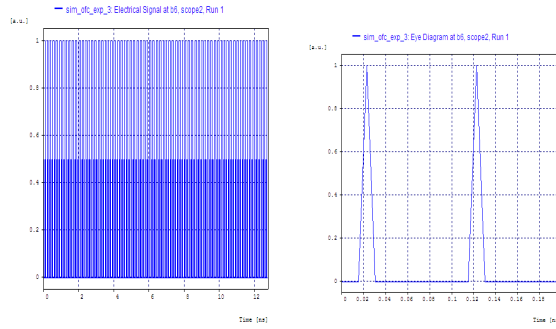

D. Output of Photo Diode

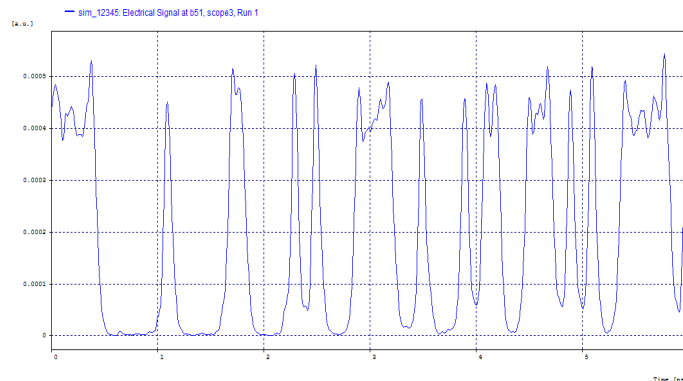
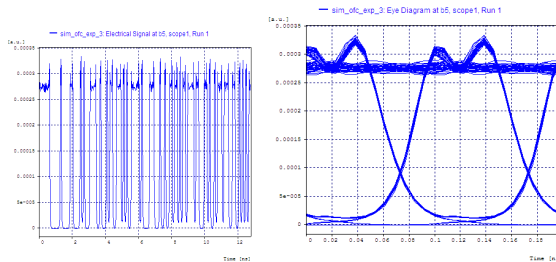

E. Block Diagram

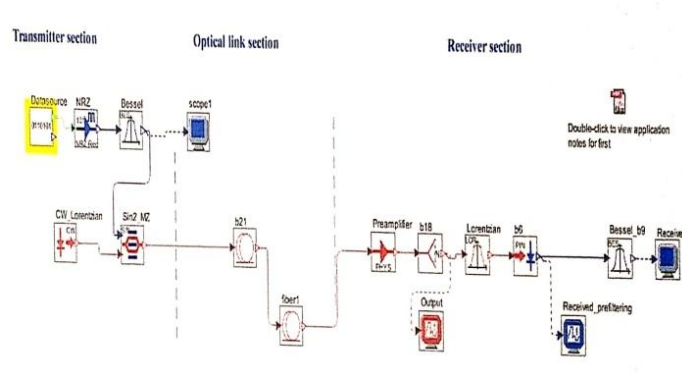

Graph of Electrical Signal And Eye Pattern (for $D = 16 \text{ ps/nm/km}$, $\alpha = 4 \text{ dB/km}$):

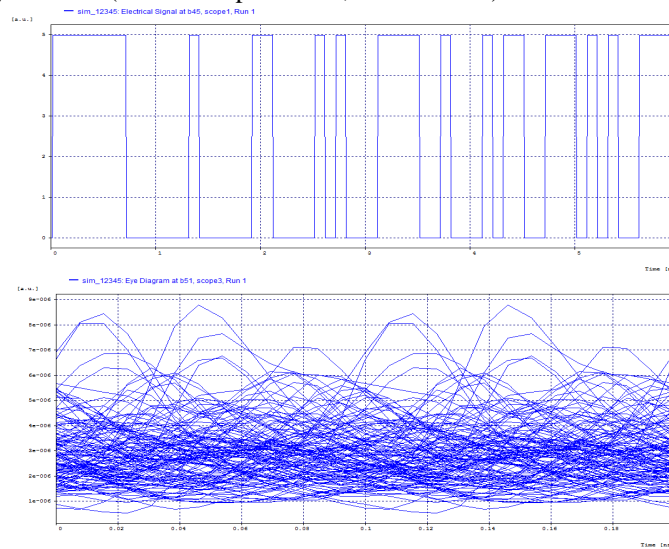

Graph of Electrical Signal And Eye Pattern (for $D = 16 \text{ ps/nm/km}$, $\alpha = 0.5 \text{ dB/km}$):

Graph of Electrical Signal And Eye Pattern (for $D = 16 \text{ ps/nm/km}$, $\alpha = 0.2 \text{ dB/km}$):

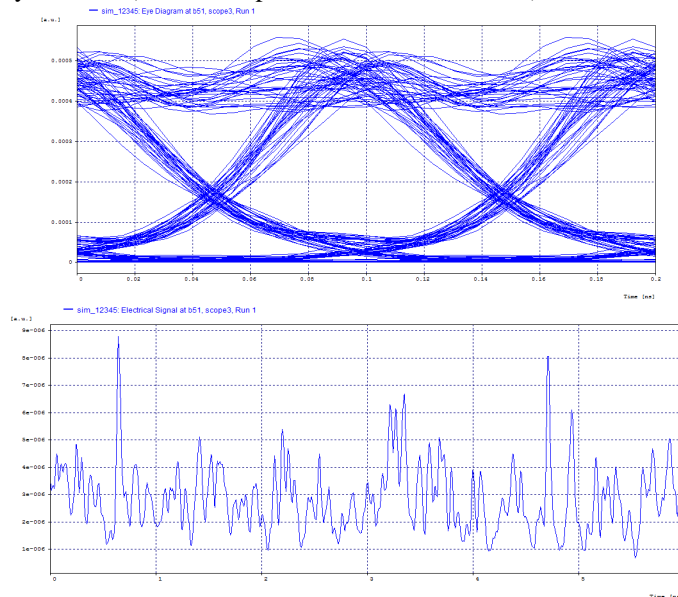

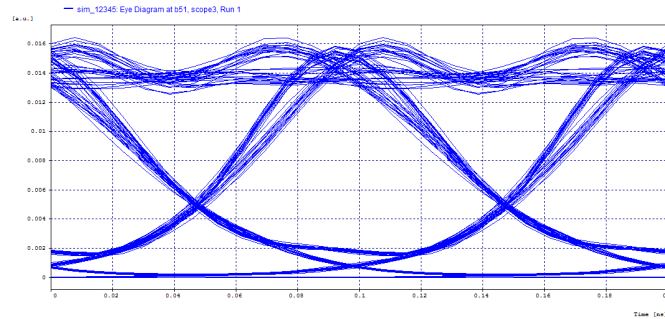

III. CONCLUSIONS

We learnt from this experiment that Attenuation increases, Q - factor decreases and jitter increases.

Also, as Dispersion increases, Q – factor decreases. From observation and block diagram set up we have analyzed that the effect of different sources in optical fiber using OPTISIM software

REFERENCES

- [1] "Optical Fiber Communications"- Gerd Keiser-Fourth Edition-TATA McGRAW HILL
- [2] "Fiber Optics Communication System"-G.P.Agarwal-Wiley Publications
- [3] "An Introduction to Fiber Optic Systems"-John Power-McGrawHill-
- [4] "Fiber Optics Communications"- Harold Kolimbris-Pearson Education



10.22214/IJRASET



45.98



IMPACT FACTOR:
7.129



IMPACT FACTOR:
7.429



INTERNATIONAL JOURNAL FOR RESEARCH

IN APPLIED SCIENCE & ENGINEERING TECHNOLOGY

Call : 08813907089  (24*7 Support on Whatsapp)