



iJRASET

International Journal For Research in
Applied Science and Engineering Technology



INTERNATIONAL JOURNAL FOR RESEARCH

IN APPLIED SCIENCE & ENGINEERING TECHNOLOGY

Volume: 6 Issue: III Month of publication: March 2018

DOI: <http://doi.org/10.22214/ijraset.2018.1206>

www.ijraset.com

Call:  08813907089

E-mail ID: ijraset@gmail.com

Speed Performance Analysis and Control of DC Servomotor Using Linear & Nonlinear Controller

Arnob Senapati¹, Abhishek Kumar Kashyap², Binanda Kishore Mondal³, Souvik Chattarjee⁴

¹ UG Student, Department of ICE, Maulana Abul Kalam Azad University of Technology, West Bengal.

^{2, 3, 4} Assistant Professor, Department of ICE, Maulana Abul Kalam Azad University of Technology, West Bengal.

Abstract: The speed control system is one of the interesting terms in control system engineering. Nowadays several control system algorithm have been applied in that application. PID controller is a well known controller and widely used in feedback control in industrial processes. For speed control system sometime PID controller is not accurate for this application because of non linear element present in the system. Therefore in this research the fuzzy logic controller and IMC controller is proposed to overcome the problem of PID controller. Fuzzy logic controller and IMC controller has an ability to overcome the problem of PID controller. A mathematical model of the process has been developed using real plant data and then conventional controllers, Fuzzy logic controller and IMC controller has also been designed. A comparative analysis of performance evaluation of all controllers has been done.

Keywords: PID Controller, Fuzzy Logic Controller, IMC Controller, AMIGO Tuning, Speed Control, DC Servomotor.

I. INTRODUCTION

DC motors are widely used in industrial applications, robot manipulators and home appliances because of their high reliability, flexibility and low cost where speed and position control of motor are required. This paper deals with the performance evaluation of different types of conventional controllers and intelligent controllers implemented with a clear objective to control the speed of separately excited DC motor. A motor that converts electrical energy into mechanical energy are generally of two types i.e. AC motor & DC motor. A simple DC motor uses electricity and magnetic field that produces torque which rotate the motor. PMDC permanent magnet DC motor outperforms to AC motor because it provides better speed control on high torque loads and is used in wide industrial application. The applied voltage describes the speed of motor while current in the armature windings shows the torque.

II. SPEED CONTROL OF DC MOTOR

Speed control stands for intentional speed variation carried out manually or automatically. DC motors are most suitable for wide range speed control and therefore is used in many adjustable speed drives.

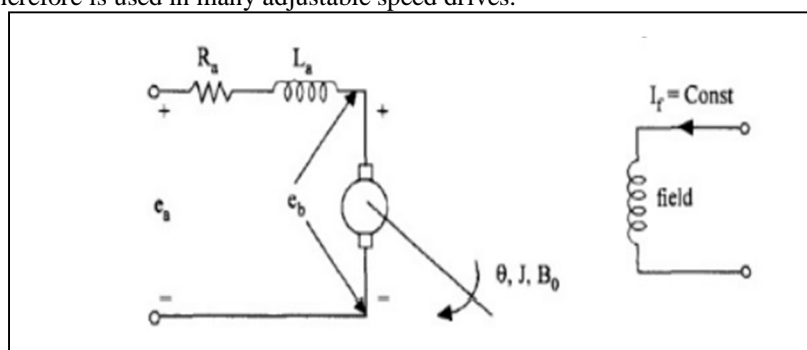

Figure 1: DC servomotor model

The above diagram shows the model of the DC servomotor. In this project we deal with the armature controlled dc motor where the field is constant. The parameters of the armature controlled dc motor are listed below.

Where,

R_a = armature-winding resistance (Ω)

L_a = armature-winding inductance, (H)

I_a = armature current, (A)

I_f = field current(A)

E_a = applied armature voltage (V)

E_b = back emf (volts)

θ = angular displacement of the motor shaft, (rad)

T_M = torque delivered by the motor, (Nm)

J = equivalent moment of inertia of the motor and load referred to the motor shaft ($\text{kg}\cdot\text{m}^2$)

F = viscous-friction coefficient of the motor and load referred to the motor shaft, (NM/(rad/s))

A. Specification of DC Motor

Table 1: Specification of DC motor

Armature-winding resistance (R_a)	1 ohm
Armature-winding inductance (L_a)	0.5 H
Moment of inertia of the motor(J)	0.01 kg-m
Armature current (I_a)	0.1 Amp
Applied armature voltage (V_a)	220 volt
Viscous-friction coefficient of the motor (B_0)	0.1 N-m/rad/sec
Back emf constant(K_b)	0.01V/(rad/sec)
Motor torque constant (K_T)	0.01N-m/A

B. We Know that the Armature voltage Equation is Given by

$$V_a = E_b + I_a R_a + L_a (dI_a/dt) \text{ ----- (1)}$$

The back emf is given by:

$$E_b = K_b * \omega \text{ } [\omega = d\theta/dt] \text{ ----- (2)}$$

As we know that $[\omega = d\theta/dt]$

Now the torque balance equation will be given by:

$$T_m = Jd\omega/dt + F \omega \text{ ----- (3)}$$

The transfer function of the armature controlled DC servomotor is given by:

$$G_m(s) = \frac{K_T}{s(R_a + sL_a)(sJ + F) + sK_b K_T}$$

We design the system according to the specification given by the above table [1] for armature controlled dc motor

$$G_m(s) = \frac{2}{s^2 + 12s + 20.02}$$

III. SPEED CONTROL WITH LINEAR CONTROLLER

PID (proportional–integral–derivative) controller used as a linear controller for control process with good response. A PID controller is widely used in industrial control systems. It is a generic control loop feedback mechanism and used as feedback controller. PID working principle is that it calculates an error value from the processed measured value and the desired reference point. The work of controller is to minimize the error by changing in the inputs of the system.

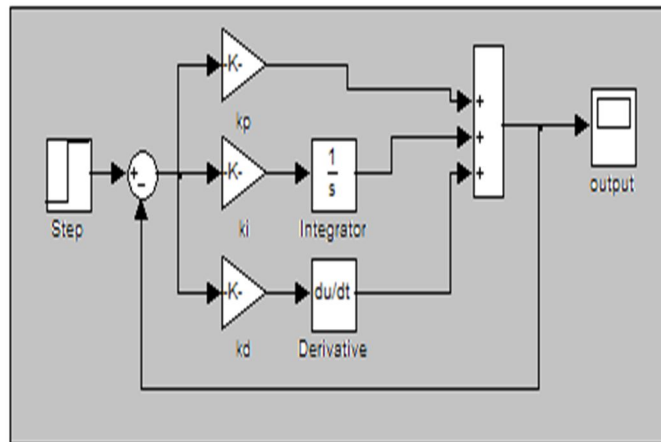

Figure 2: Block Diagram of PID controller

A. Tuning Of PID Controller

PID controllers are probably the most widely used industrial controller. PID tuning method is a popular method of tuning PID controller. In closed loop tuning method, a critical gain K_c is induced in the forward path of the control system. The high value of the gain takes the system to the verge of instability. It creates oscillation and from the oscillations, the value of frequency and time are calculated. Open loop tuning method which is known as process reaction curve method, in this method a process reaction curve is generated in response to a disturbance. This process curve is then used to calculate the controller gain, integral time and derivative time. The method is performed in open loop so that no control action occurs and the process response can be isolated. Here, all the tuning rules are compared on the basis of Rise Time (T_r), Settling Time (T_s), Maximum Overshoot (M%) and their corresponding Performance Indices (PI) like Integral Square Error (ISE), Integral Time Square Error (ITSE), Integral Absolute Error (IAE), and Integral Time Absolute Error (ITAE).

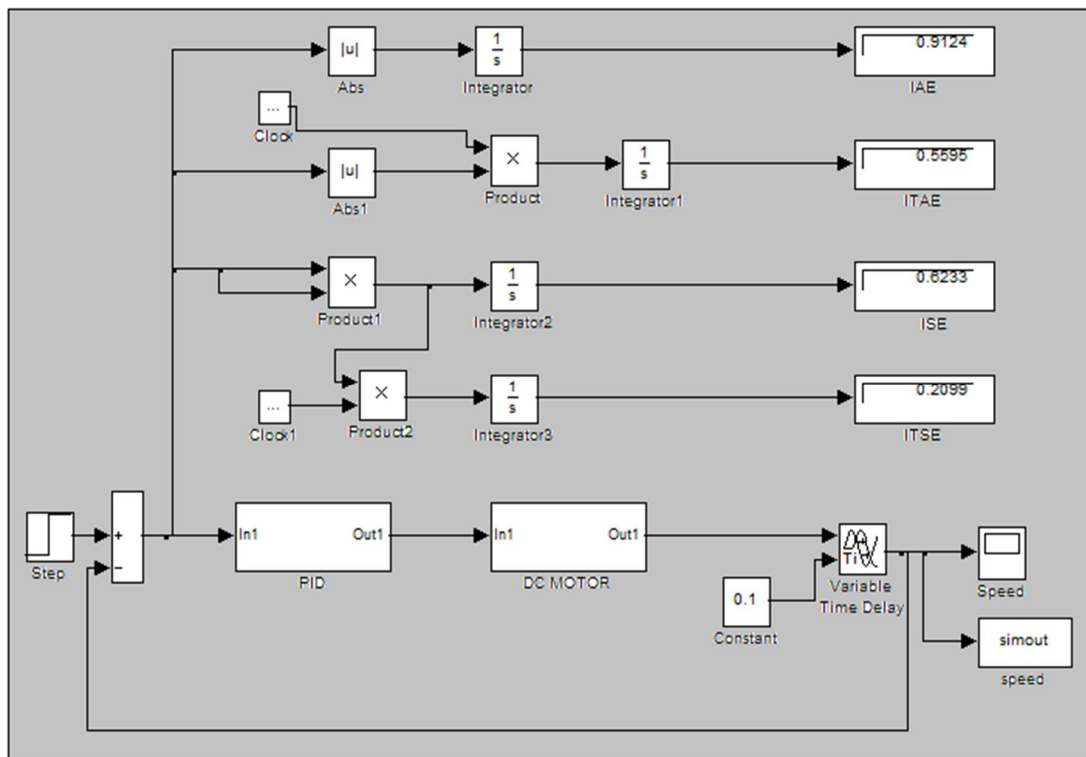

Figure 3: Simulink Model of the DC Servomotor with PID Controller

1) *Ziegler and Nichols tuning method:* Ziegler and Nichols proposed rules for determining values of K_p , K_d and K_i based on the transient response characteristics of a given plant. Closed loop oscillation based PID tuning method is a popular method of tuning PID controller. In this kind of tuning method, a critical gain K_c is induced in the forward path of the control system. The high value of the gain takes the system to the verge of instability. It creates oscillation and from the oscillations, the value of frequency and time are calculated.

Table 2: Ziegler and Nichols Table

Controller	K_p	T_i	T_d
P	$0.5K_c$	-	-
PI	$0.45K_c$	$T_u/1.2$	-
PID	$0.6K_c$	$T_u/2$	$T_u/8$

Table 3: AMIGO Table

Amplitude

Time

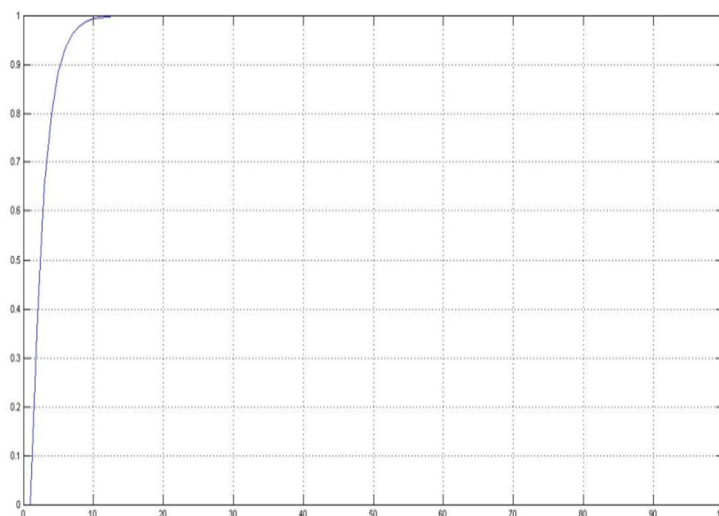

Figure 4: Ziegler and Nichols PID Response

From the close loop oscillation method we find the ultimate gain $K_c = 13.6434$ and ultimate period $T_u = 3$. Which implies $K_p = 8.18604$, $K_i = 5.4573$, $K_d = 2.9469$. The corresponding Amplitude vs. Time Plot for PID is shown in Figure 4, obtained for the controller parameters calculated in the above Table 2.

2) *AMIGO (Approximate M- constraint Integral Gain Optimization) Tuning Rule:* The Z-N rule does not give the satisfactory control. Therefore there have been many modifications of the method that retain the simplicity but give improve the robustness. The AMIGO (Approximate M-constraint Integral Gain Optimization) tuning rule designed to maximize the controller integral gain subjected to robustness constraints express by maximum sensitivities. The process models were then approximated by simple models and relations between model parameter and controller parameter.

Controller	K	Ti	Td
PI	0.16Ku	$\frac{Tu}{1 + 4.5v}$	-----
PID	$(0.3 - 0.1v^4)Ku$	$\frac{0.6Tu}{1 + 2v}$	$\frac{0.15(1 - v)Tu}{1 - 0.95v}$

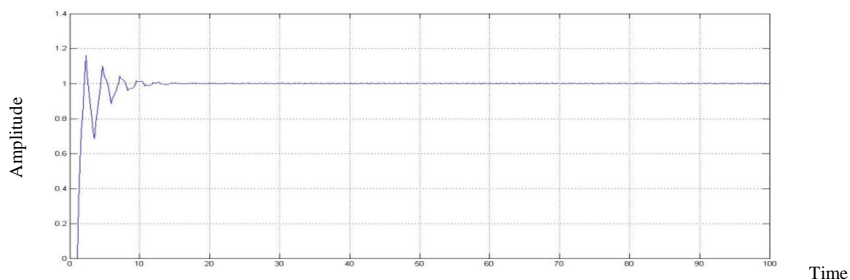

Figure 5: AMIGO PID Response

From the close loop oscillation method we find the ultimate gain $K_c = 13.6434$ and ultimate period $T_c = 3$ where, $v = (1/K_p * K_c)$. Which implies $K_p = 3.697$, $K_i = 5.069$, $K_d = 1.4601$. The corresponding Amplitude vs. Time Plot for PID is shown in Figure 5, obtained for the controller parameters calculated in the above Table 3.

3) *Chien-Hrones-Reswick Tuning Rule*: This method is a modified of the original Ziegler-Nichols method. It was produced by Chien-Hrones-Reswick in 1952 with a better control to the response overshoot. Compared with the traditional Ziegler-Nichols tuning formula, Chien-Hrones-Reswick method also uses the time constant T and the parameters found from the step response of the open-loop system.

Controller	K_p	K_i	K_d
P	$0.3T_g/K_s * T_u$	-----	-----
PI	$0.35T_g/ K_s * T_u$	$0.292/ K_s * T_u$	-----
PID	$0.6T_g/ K_s * T_u$	$0.6/ K_s * T_u$	$0.3T_g/K_s$

Table 4: Chien-Hrones-Reswick Table

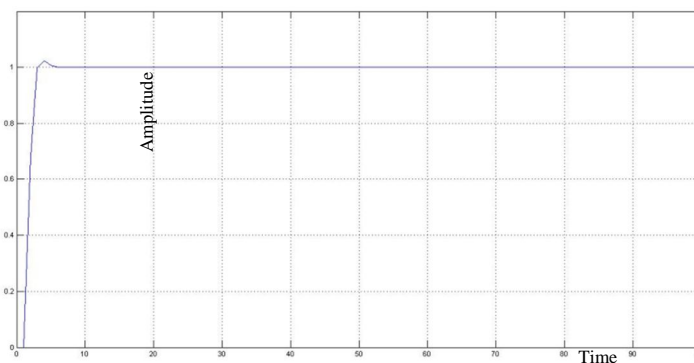

Figure 6 : Chien-Hrones-Reswick PID Response

From the open loop oscillation method we find the static gain $K_s = 1$, dead time $T_u = 0.2$, time constant $T_g = 0.8$. Which implies $K_p = 4.8$, $K_i = 12$, $K_d = 0.48$. The corresponding Amplitude vs. Time Plot for PID is shown in Figure 6, obtained for the controller

parameters calculated in the above Table 4. of linear controller with different tuning rules is analyzed. The result shows that the linear controller with different tuning rule achieves better performance while tuning the controller gains for different cases such as eliminating overshoot, rise time and steady state error. Performance Analysis data obtained from the simulation and responses have been tabulated in Table 5.

Table 5: Performance Analysis of DC Servomotor with Linear Controller

Transfer Function	Linear controller with Tuning Rule	Rise Time (Tr) (sec)	Settling Time (Ts) (sec)	Maximum Overshoot (M %)	Integral Absolute Error (IAE)	Integral Time Absolute Error (ITAE)	Integral Square Error (ISE)	Integral Time Square Error (ITSE)
Gm(s)	PID with Ziegler and Nichols Rule	1.8	10.7	16.2	1.834	4.11	0.8235	0.7048
Gm(s)	PID with AMIGO Rule	5	8.5	0	1.975	3.473	1.077	0.9247
Gm(s)	PID with Chien-Hrones-Reswick Rule	2.5	5	2.4	0.9124	0.5595	0.6233	0.2099

IV. SPPEED CONTROL WITH NON LINEAR CONTROLLER

Nonlinear control theory is the area of control theory which deals with systems that are nonlinear, time-variant, or both. Control theory is an interdisciplinary branch of engineering and mathematics that is concerned with the behavior of dynamical systems with inputs, and how to modify the output by changes in the input using feedback. Fuzzy logic controller, IMC controller, Model predictive controller, Model reference adaptive controller which gives expert output in automatic control strategies. In this project we discussed on Fuzzy logic controller, IMC controller and analyzed the performance by applying on DC Servomotor.

A. Fuzzy Logic Controller

The Fuzzy Logic Controller is intended to have two Fuzzy state Variables and one control variable for accomplishing speed control of the DC Servomotor. Fuzzy controllers are very simple conceptually. They consist of an input stage, a processing stage, and an output stage. The input stage maps sensor or other inputs, such as switches, thumbwheels, and so on, to the appropriate membership functions and truth values. The processing stage invokes each appropriate rule and generates a result for each, then combines the results of the rules. Finally, the output stage converts the combined result back into a specific control output value. The most common shape of membership functions is triangular, although trapezoidal and bell curves are also used, but the shape is generally less important than the number of curves and their placement. In Figure 7 shows a block diagram of Fuzzy logic based control system.

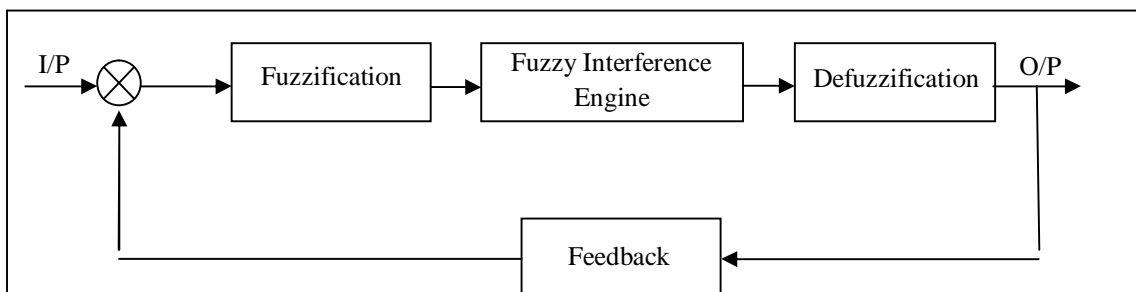

Figure 7: Block Diagram of Fuzzy Logic Based Control System

For the fuzzy logic controller the input variables are error (E) and rate change of error (ΔE), and the output variable is controller output (Speed). Triangular membership functions are used for input variables and the output variable. Each variable has 5 membership functions. Thus, there were total 25 rules generated. The universe of discourse of error, rate of error and output are [0, 1], [0, 1] and [0, 1.5] respectively. The rule base framed for DC motor is tabulated in Table 7. Linguistic variables for error, rate of error and controller output are tabulated in Table 6.

Table 6: Linguistic variables

NL	NS	ZE	PS	PL
Negative Large	Negative Small	Zero Error	Positive Small	Positive Large

Table 7: Rule Base Framed for DC Servomotor

E/ ΔE	NL	NS	ZE	PS	PL
PL	ZE	PS	PL	PL	PL
PS	NS	ZE	PS	PL	PL
ZE	NL	NS	ZE	PS	PL
NS	NL	NL	NS	ZE	PS
NL	NL	NL	NL	NS	ZE

Figure (8) shows the Fuzzy logic controller designed in MATLAB Simulink by using the rule base designed above in table 7. It shows the simulink model for DC Servomotor.

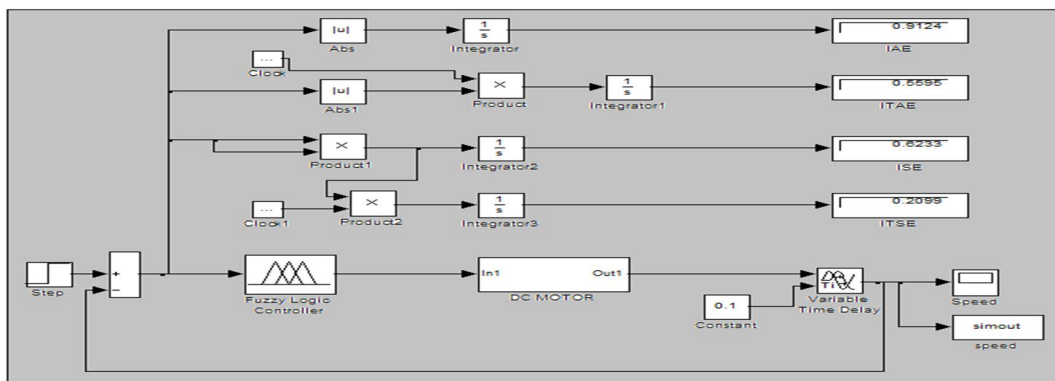

Figure 8: Simulink Model of the DC Servomotor with Fuzzy Logic Controller

The corresponding Amplitude vs. Time Plot for Fuzzy Logic Controller shown in Figure (9).

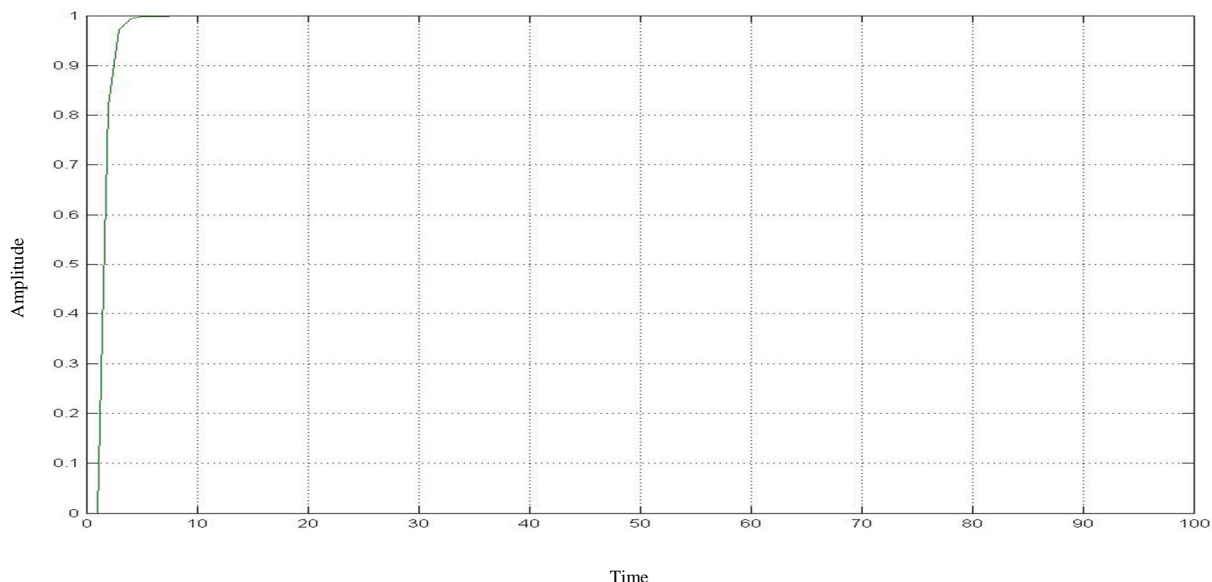

Figure 9: Fuzzy Logic Controller Output

B. Internal Model Control

The theory of Internal Model Controller states that “control can be achieved only if the control system encapsulates, either implicitly or explicitly, some representation of the process to be controlled”. The Internal Model Controller is based on the inverse of the process model we are trying to control. If we cascade the process transfer function with a controller which is the exact inverse of the process, then effectively the gain becomes unity and we have perfect set-point tracking. The main feature of internal model controller is that the process model is in parallel with the actual process. Figure 10, shows the scheme of IMC. Internal model controller provides a transparent framework for control system design and tuning.

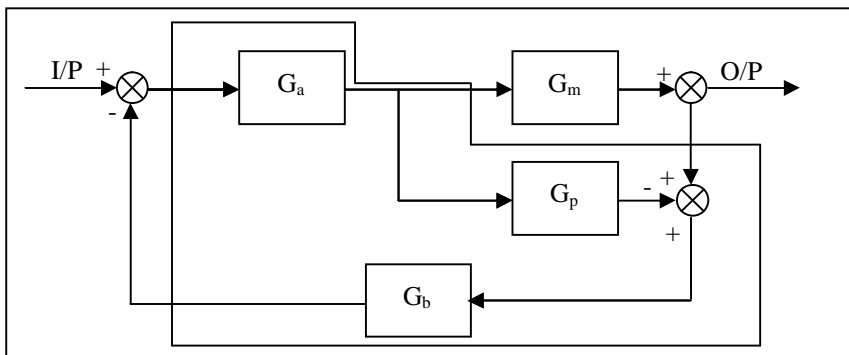

Figure 10: Internal Model Controller

Here G_p is the transfer function of DC Servomotor $G_p(s) = \frac{2}{s^2 + 12s + 20.02}$.

G_m is the model of the DC Servomotor and G_b is the feedback which is unity.

G_a is the low pass filter is $G_a = \frac{1}{1 + \tau s}$ where τ is the time constant here we choose the value is 0.9.

$G_c = \frac{s^2 + 12s + 20.02}{(1 + 0.9s)^2}$ which is the controller transfer function.

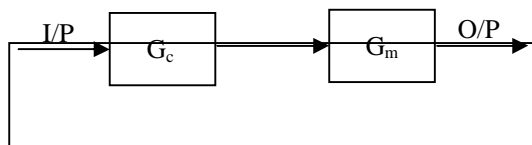

Figure 11: Equivalent Block diagram of IMC

Figure (11) shows the equivalent block diagram of the IMC controller which is implies in MATLAB simulink block.

According to the IMC controller block diagram designed in MATLAB simulink. In Figure 12 shows the simulink model of the DC Servomotor with IMC controller.

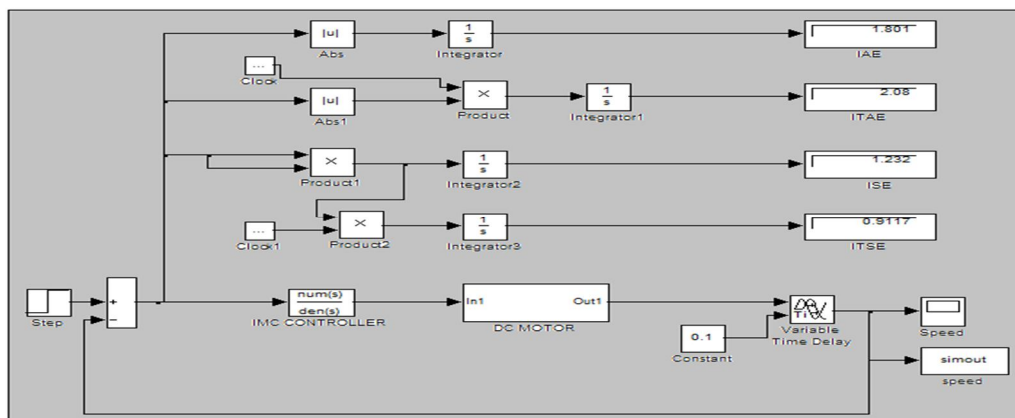

Figure 12: Simulink Model of the DC Servomotor with IMC Controller.

The corresponding Amplitude vs. Time Plot for Internal Model Controller shown in Figure 13.

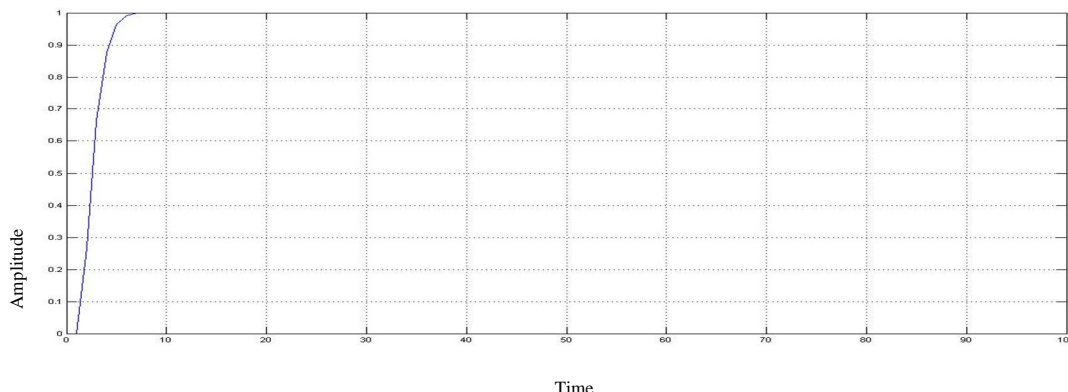

Figure 13: IMC Controller Output

Here performance of the different non linear controllers is analyzed. The results shows that the different nonlinear controllers achieve better performance while tuning the controller gains for different cases such as eliminating overshoot, rise time and steady state error. Performance Analysis data obtained from the simulation and responses have been tabulated in Table 8.

Table 8: Performance Analysis of DC Servomotor with Non Linear Controller

Transfer Function	Non linear Controller	Rise Time (T_r) (sec)	Settling Time (T_s) (sec)	Maximum Overshoot (M %)	Integral Absolute Error (IAE)	Integral Time Absolute Error (ITAE)	Integral Square Error (ISE)	Integral Time Square Error (ITSE)
DC Motor	Fuzzy Logic Controller	3	4	0	0.7921	2.026	0.4848	0.1234
DC Motor	Internal Model Controller	4.5	6	0	1.801	2.08	1.232	0.9117

V. CONCLUSION

This paper discusses the design of the linear and nonlinear controller for the DC Servomotor speed control system. Here linear controller as PID controller with Three popular methods implemented and analyzed using MATLAB to create a friendly environment for study each method techniques and effect on the system response performance. Final results show that each method has its specific advantage over the others. For the chosen DC Servomotor speed control transfer function, it has been shown that the Ziegler-Nichols gives faster system response with acceptable overshoot with oscillation while AMIGO yields zero overshoot with greater settling time than Chien-Hrones-Reswick but less than Ziegler-Nichols while Chien-Hrones-Reswick yields lower overshoot with acceptable system transient response. The non linear controller with Fuzzy Logic controller and Internal Model Controller are hereby implemented and analyzed for the speed performance of DC Servomotor using MATLAB. Final results show that each method has its specific advantage over the others. In this paper, comparative studies of performance of different non linear controllers as fuzzy logic controller and IMC controller have been studied. After the comparison of results and simulations, it is found that the Fuzzy Logic Controller gives better response than IMC. Here Fuzzy Logic Controller and IMC both have zero overshoot but fuzzy settles earlier than IMC. After careful investigation it is found that its performance index is satisfactory than IMC. Hence it is concluded that the proposed Fuzzy Logic Controller provides better performance characteristics and improves the speed control of DC motor.

In this paper we studied both linear and non linear controller and we conclude that non linear controller gives better performance than linear controller as it takes into account the other non-linearity associated with the controller and plant. But in small scale industries like food and beverage industries linear controller can be work with good accuracy and it is not highly expensive, so there no needs of use non linear controller. Now in case of high scale industries like thermal power plant or steel plant non linear controller works with good accuracy where linear controllers are not give satisfactory result.

VI. ACKNOWLEDGMENT

I hereby express my sincere gratitude to the Assistant prof. A.K.Kashyap, Dept. of Instrumentation and Control Engineering for providing us with the necessary arrangement for the completion of my project. Also express my sincere gratitude to the Assistant prof. Binanda Kishore Mandal and Assistant prof. Souvik Chattarjee for guide me every step for the completion of the project. Without their valuable guidance and support the project would not have been a success. I thank them for the good will and encouragement extended to us.

REFERENCES

- [1] Nagrath, I.J. and M. Gopal, Control Systems Engineering, 3rd edition, New Age Publishers, 2000
- [2] Driankov, D., H. Hellendoorn and M. Reinfrank, An Introduction to Fuzzy Control, 2nd edition, Springer International Student Edition, 2001
- [3] Klir, G.J. and Bo Yuan, Fuzzy Sets and Fuzzy Logic: Theory and Applications, Prentice Hall International, 1995
- [4] M.Saranya and D.Pamela, "A Real Time IMC Tuned PID Controller for DC Motor", International Journal of Recent technology and Engineering, ISSN: 2277-3878, Volume-1, Issue-1, April 2012, Introduction to, Fuzzy Sets, Fuzzy Logic and Fuzzy] Control System, CRC Press, 2001
- [5] K. S. Tang, Kim Fung Man, Guanrong Chen, and Sam Kwong, "An Optimal Fuzzy PID Controller" IEEE Transactions on Industrial Electronics, 48(4), 2001
- [6] Maki K. Habib, "Designing of Fuzzy Logic Controllers for DC Servomotor Supported by Fuzzy Logic Control Development Environment" IECON01: The 27th Annual Conference of the IEEE Industrial Electronics Society, 2001
- [7] C. Lee, "Fuzzy Logic in Control Systems: Fuzzy Logic Controller, Part II" IEEE Transactions on Systems, Man, and Cybernetics, 20(2), 2000
- [8] George K. I. Mann, Bao-Gang Hu, Raymond G. "Analysis of Direct Action Fuzzy PID Controller Structures, IEEE Transactions on Systems, Man, and Cybernetics—Part B: Cybernetics, 29(3), 1999.
- [9] M. F. A. Rahmat and M. M. Ghazaly. 2006. Performance Comparison between Pid and Fuzzy Logic Controller in Position Control System of Dc Servomotor. Journal Teknologi. 45: 1-17
- [10] P. I-Hai Lin, S. Hwang and J. Chou. 1994. Comparison on fuzzy logic and PID controls for a DC motor position controller. In Industry Applications Society Annual Meeting. Conference Record of the 1994 IEEE. 3: 1930-1935
- [11] K Ogata. Modern Control Engineering. New Jersey: Prentice-Hall, Inc. 2010
- [12] DPA Dingyu Xue, Yang Quan Chen. Linear Feedback Control. In Linear Feedback Control, Philadelphia: Society for Industrial and Applied Mathematics. 2007: 183-235
- [13] KH Raunt, SR Vaishnay. A Study on Performance of Different PID Tuning Techniques. NJIEEEICE. 1-4.



10.22214/IJRASET



45.98



IMPACT FACTOR:
7.129



IMPACT FACTOR:
7.429



INTERNATIONAL JOURNAL FOR RESEARCH

IN APPLIED SCIENCE & ENGINEERING TECHNOLOGY

Call : 08813907089  (24*7 Support on Whatsapp)