



iJRASET

International Journal For Research in
Applied Science and Engineering Technology



INTERNATIONAL JOURNAL FOR RESEARCH

IN APPLIED SCIENCE & ENGINEERING TECHNOLOGY

Volume: 6 Issue: 1 Month of publication: January 2018

DOI: <http://doi.org/10.22214/ijraset.2018.1359>

www.ijraset.com

Call:  08813907089

E-mail ID: ijraset@gmail.com

IOT based Smart Water Tank with Android Application

Bandari Theja¹

¹ Asst. professor, ECE dept, St Martins Engineering College ,Hyderabad

Abstract: *In this paper, we introduce the project of water level monitoring as well as controlling with IoT and android application. Wastage of water in the current scenario, merely due to overflowing tanks is not affordable. Conventional water tanks can neither monitor nor control the water level in tank, leading to large amount of wastage. Some other technologies had certain drawbacks in some or the other way. The need of removal of these short-comings and providing an efficient and economical solution has been the main focus of this project.*

Keywords: *ESP 8266, Ultrasonic Sensor, Android application and Firebase*

I. INTRODUCTION

Sustaining water resource is one of the major issues surfacing recently due to uncontrolled wastage of available fresh water. Majority of the water wastage takes place because of overflowing water tanks. In most of the cases, water tanks are manually controlled by an operator. In absence of the person, water keeps on overflowing until the motor is switched off. In some other projects, which are automated, dip sensors are implemented. As a result of being in contact with water, there is a high probability of rusting of material used in sensor. These projects can only control the water level locally, i.e. the operator is required to keep an eye on proper functioning. Smart water tank implements IoT, with which, the user can directly monitor and control the working of tank through the smartphone and from any place in this world. The android application is developed in MIT app inventor 2. This project can be installed in existing water tanks with no requirement new tank for this purpose. This paper is organized in the following ways. Chapter two concentrates on the basic concepts used in designing the entire project. Chapter 3 concentrates on system design and its implementation with all sub units. Chapter 4 is related to the data flow from sensors and app around database in cloud.

II. BASIC CONCEPTS

A. ESP 8266

It is a Wi-Fi module which can connect to internet via hotspot by using its SSID and Password. It can be programmed to implement logic statements as per requirement of the project. The ultrasonic sensor reads the distance of water surface and returns it to ESP. The ESP, when connected to internet, uploads this value to the cloud database. Also it retrieves some values from the database which are set by user in the android application. Accordingly, the functioning of motor depends upon the current water level and the maximum and minimum values.

B. Ultrasonic Sensor

Ultrasonic sensor is used to generate ultrasonic sound waves which are bombarded on the surface of water. This sensor consists of a speaker which emits an ultrasonic sound wave and a mic which detects that particular sound wave. As we have implemented the ultrasonic sensor, there is no contact of water with sensor which ensures long life of the sensor.

C. Cloud – Firebase

Firebase is a cloud provided by Google which implements JSON language. Here, the values from the android application and ESP are stored. The values are then accessed by ESP and app by using some functions. Special authentication key is required to access these values which ensures security of the data.

D. MIT app inventor – Android application

This is a scratch programming platform designed by MIT to help the programmers for developing and testing android applications. We have created our application with this software. In this app, the user has to set the maximum and minimum values of water level in the tank. Also, the current water level in tank is displayed in app. The app

uses a login interface which ensures security in using the application.

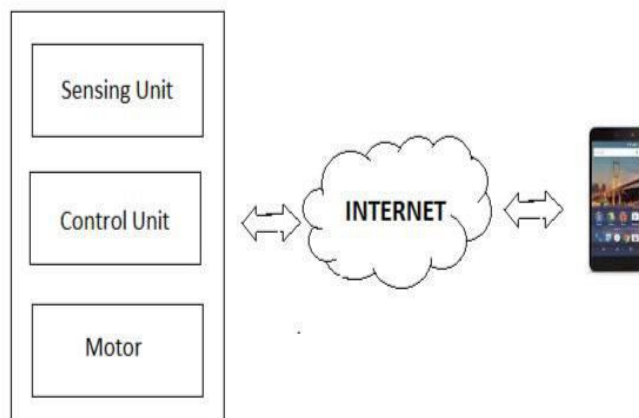

Fig1. Basic block diagram

III. SYSTEM DESIGN AND IMPLEMENTATION

For this project, we have used ESP 8266 as microcontroller. The values of maximum and minimum levels are obtained by ESP from Firebase cloud. These values are set from the android app. The current level of water is obtained from the ultrasonic sensor. Depending upon these values, the motor is turned ON / OFF.

A. Proposed Working of Water Tank And Motor

Sr.	Conditions of water level	Motor Status
1	Water level below minimum level	ON
2	Water level equal to or greater than maximum level	OFF
3	Water level in between minimum and maximum levels	Status can be controlled by the user

Table 1: proposed working

Depending on the water levels, as described above, the status of motor will be automatically controlled. If water level is in between both the levels, then the user can exercise *control* by toggling the status of motor from the android application. Buttons – Start and Abort have been provided for the same.

The application is designed in such a way that it will show the instantaneous value of current status of water in percentage. The height of tank is to be set once in ESP. This height shall be used to determine the percentage of water. Calculations of the current water level will be done with this. Making decisions with percentage proves to be easier to implement the logic in programming.

B. Flowchart (Overview)

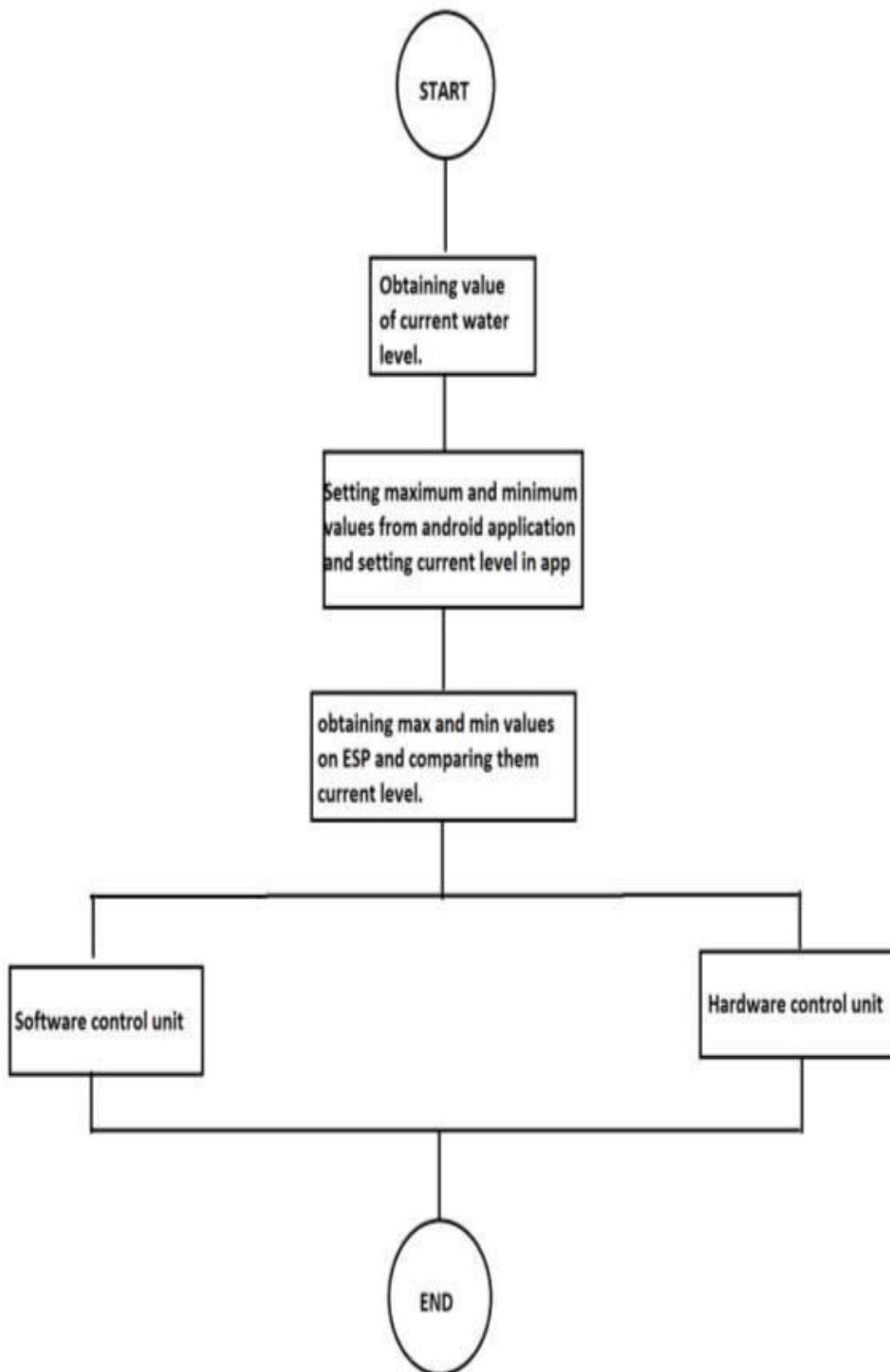

Fig 2. Overall flowchart

C. Implementation is ESP

Flowchart of working in ESP8266

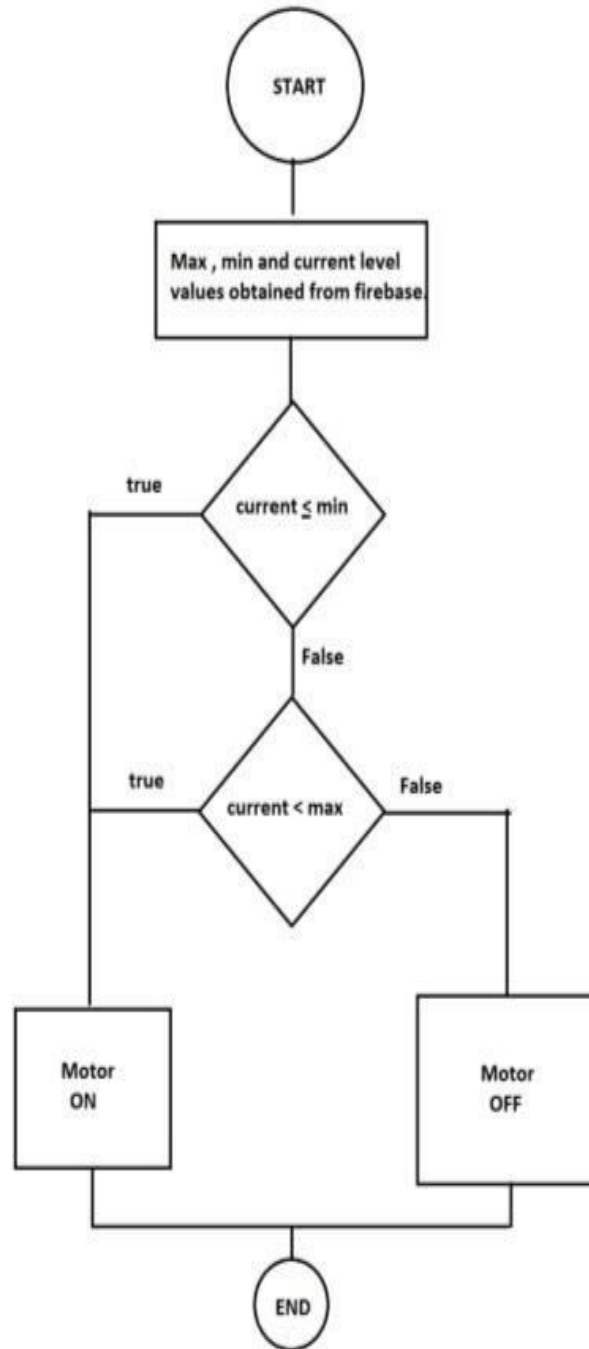
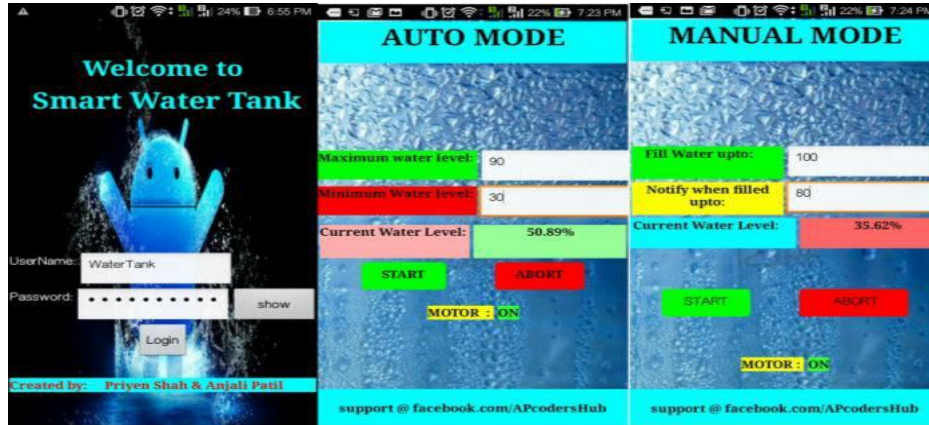

Fig 3. Flowchart of logic in ESP

ESP8266 is used as a microcontroller with the program flashed on it. The current level of water is obtained from the ultrasonic sensor. Maximum and minimum values are set by user. ESP8266 accesses the hotspot with its SSID and Password. Once it gets access to internet, these values are stored in ESP. When the current values equals or goes below the minimum level, the motor automatically starts and when water level reaches the maximum level, the motor turns off automatically. As a result, there is no overflowing of water.

D. Ultrasonic sensor

The sensor primarily creates an ultrasonic wave by supplying HIGH input to trigger(speaker) for 2 microseconds and LOW input for 10 microseconds. This wave is then detected by echo(mic). The time required for emitting and receiving the wave is calculated and stored in a variable 'dur'. As speed = distance / time, Fig 5. Screenshots of application Distance = speed of sound in air * dur / 20000 This gives distance in centimeters. This is then converted into percentage of water in tank. This is the current water level.



Complete circuit diagram:

E. Implementation in Android application

Block Diagram of logic in app:

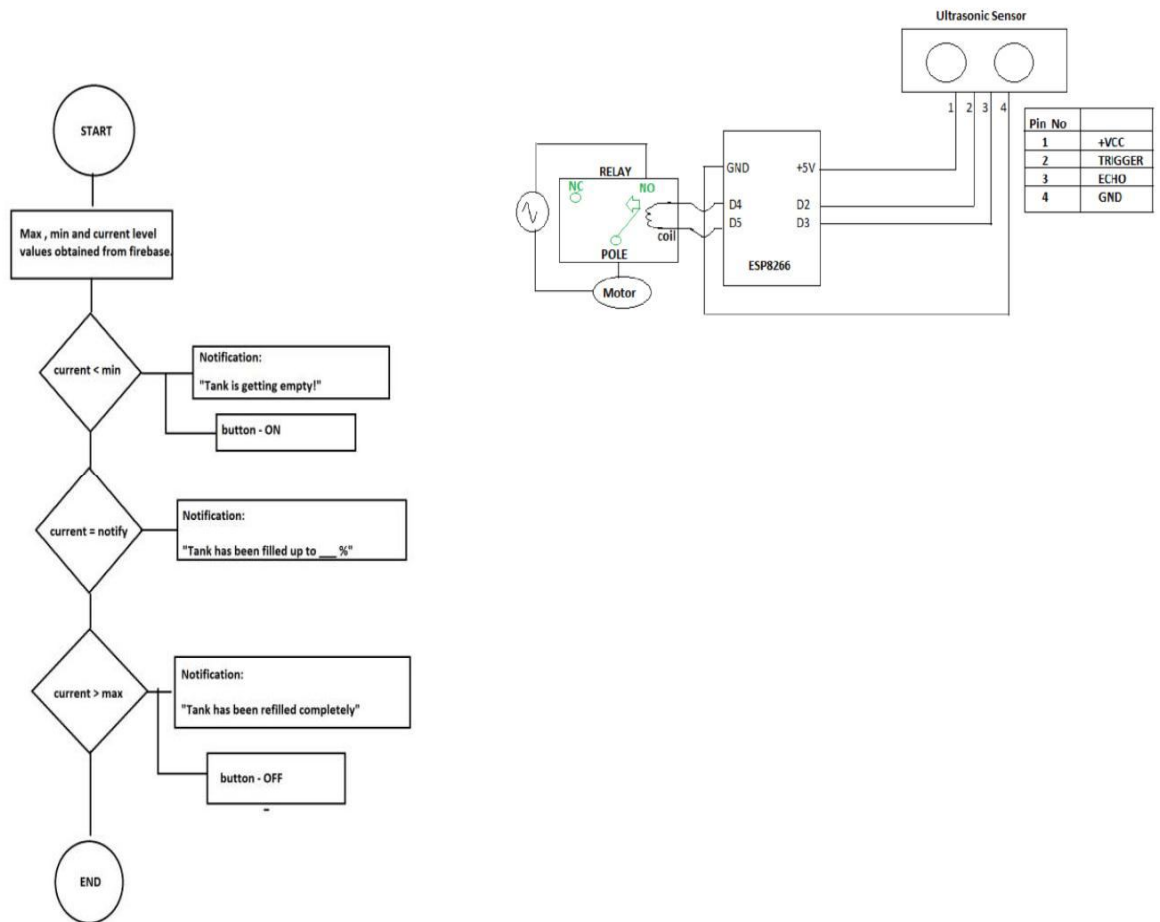

Fig 6. Water level management block

IV. PROPOSED DATA FLOW

The data flow from ESP to Android app:

A. Data collection in Cloud

- 1) *Step 1:* The current water level obtained is stored in a variable in ESP. From here it is uploaded into cloud.
- 2) *Step 2 :* The maximum and minimum values are input and stored locally in smartphone. Then these values are uploaded on the cloud. user about the status of motor and water level.

V. CONCLUSION AND FUTURE SCOPE

Water is one of the most important basic needs for all living beings. According to Wikipedia, 97% water is present in Seas and Oceans. That means only 3% of available water is present as fresh water. Out of this 3%, only 1% of water is available for consumption. But unfortunately a huge amount of water is being wasted because of uncontrolled use and exploitation of water resource. Some other automated water level monitoring systems are also present, but so far most of the methods have some shortcomings in practice. We tried to overcome these problems and implemented an efficient automated water level monitoring and controlling system. Our intension of this research work was to establish a flexible, economical, easy configurable and most importantly, a portable system which can solve our water wastage problem. We have used ESP and Ultrasonic sensor which reduces cost effectively and makes this project economical. Also, this project doesn't require special different tank for it, existing water tanks can be used. We have successfully implemented this project.

VI. FUTURE SCOPE

This project has enormous applications. It can be installed in the following areas:

- A. Private houses or bungalows
- B. Housing societies
- C. Apartments
- D. Institutions like schools and colleges, hostels
- E. Hospitals
- F. Offices
- G. Municipal overhead tanks (with slight changes in hardware)

This project can be implemented for a wide range of different sizes of water tanks making it a complete lyreliable solution.

REFERENCES

- [1] www.electroschematics.com/11276/esp8266-datasheet
- [2] www.electroschematics.com/8902/hc-sr04-datasheet
- [3] www.arduino.cc/en/Tutorial/HomePage
- [4] [www.github.com/firebase/firebase-arduino](https://github.com/firebase/firebase-arduino)
- [5] en.wikipedia.org/wiki/Water_distribution_on_Earth
- [6] www.instructables.com/id/Using-the-ESP8266-module
- [7] <https://github.com/esp8266>
- [8] www.instructables.com/id/Simple-Arduino-and-HC-SR04-Example
- [9] treehouseprojects.ca/ultrasonictutorial
- [10] <https://firebase.google.com/docs/database>
- [11] <https://firebase.google.com/docs/database/android/lists-of-data>
- [12] appinventor.mit.edu/explore/content/what-app-inventor.html



10.22214/IJRASET



45.98



IMPACT FACTOR:
7.129



IMPACT FACTOR:
7.429



INTERNATIONAL JOURNAL FOR RESEARCH

IN APPLIED SCIENCE & ENGINEERING TECHNOLOGY

Call : 08813907089  (24*7 Support on Whatsapp)