



iJRASET

International Journal For Research in
Applied Science and Engineering Technology



INTERNATIONAL JOURNAL FOR RESEARCH

IN APPLIED SCIENCE & ENGINEERING TECHNOLOGY

Volume: 6 Issue: IV Month of publication: April 2018

DOI: <http://doi.org/10.22214/ijraset.2018.4113>

www.ijraset.com

Call:  08813907089

E-mail ID: ijraset@gmail.com

Compensation of Voltage Dip and Voltage Swell by Dynamic Voltage Restore Using Synchronous Reference Frame Theory

A. Naveen Teja¹, S. Srinivasa Rao²

¹P.G Scholar, EEE Department, Gitam (Deemed to be University), Visakhapatnam,

²Assistant Professor, EEE Department, Gitam (Deemed to be University), Visakhapatnam,

Abstract: In this paper different voltage infusion schemes are introduced and a new method is used to reduce the rating of the Voltage Source Converter (VSC) used in DVR. A new control scheme is proposed to control the capacitor upheld Dynamic Voltage Restorer (DVR). Synchronous reference frame theory (SRF) is used for the control of DVR. The control of DVR is explained with reduced-rating VSC. The SRF theory is used for the transformation of voltages from rotating vectors to stationary frame. The compensation of Voltage dip and swell is explained with reduced rating DVR.

Keywords: Dynamic voltage restorer (DVR), Synchronous reference frame (SRF) theory, unit vector, Voltage dip, Voltage swell.

I. INTRODUCTION

Now a days, there is a heavy usage of sensitive and critical hardware components such as Programmable logic Controllers (PLCs), Personal Computers (PCs) and Adjustable Speed Drives (ASDs) etc. so Power Quality (PQ) problems are discussed in this literature. Some of the PQ problems are Voltage dips, Voltage swells, Harmonics, Interruptions, and Spikes etc. A dip is a decrease to between 0.1 and 0.9 p.u in rms voltage or current at the power frequency for durations from 0.5 cycle to 1.0 minute. Some of the causes for the dips are turning on heavy loads, loose or defective wiring and faults or short circuits, severe weather especially lightning, tree limbs. Whereas A swell is defined as an increase to between 1.1 and 1.8 p.u in rms voltage or current at the power frequency for durations from 0.5 cycle to 1.0 minute. Some of the causes for the swells are switching off of a large loads, capacitor banks energizing and transfer of loads from one power source to another. To mitigate all the above problems we use Custom Power Devices (CPDs). Even though there are many custom power devices DVR and Distribution Static Compensator (DSTATCOM) are the most effective devices. Both DVR and DSTATCOM are based on the VSC principle. But, in this paper we deal only with DVR. Therefore, DVR is a device which infuses voltage in series with the system voltage. The control and performance of a DVR with reduced rating VSC is presented in this paper. The SRF theory is used for the control of the DVR.

II. OPERATION OF DVR

The schematic of a DVR connected system has appeared in Fig. 1(a). The voltage V_{inj} is embedded with the end goal that the load voltage V_{load} is steady in magnitude and is undistorted, in spite of the fact that the supply voltage V_s isn't consistent in magnitude or is distorted [8]-[24]. Fig. 1 (b) Presents phasor diagram for DVR using various infusion schemes of the voltage. V_L (Pre-sag) is a voltage over the critical load before the dip condition. Amid the Voltage dip, the voltage is reduced to V_s with a phase edge of θ . Now, DVR infuses voltage in order to maintain the magnitude of the load voltage at pre-dip condition [9]. The voltage infusion is elucidated in four different ways. V_{inj1} shows the infused voltage in phase with supply voltage. With V_{inj2} the magnitude of the load voltage stays same yet it leads V_s by a small angle. In V_{inj3} the load voltage holds the same phase from that of the pre-dip condition, which might be an optimum angle considering the energy source.

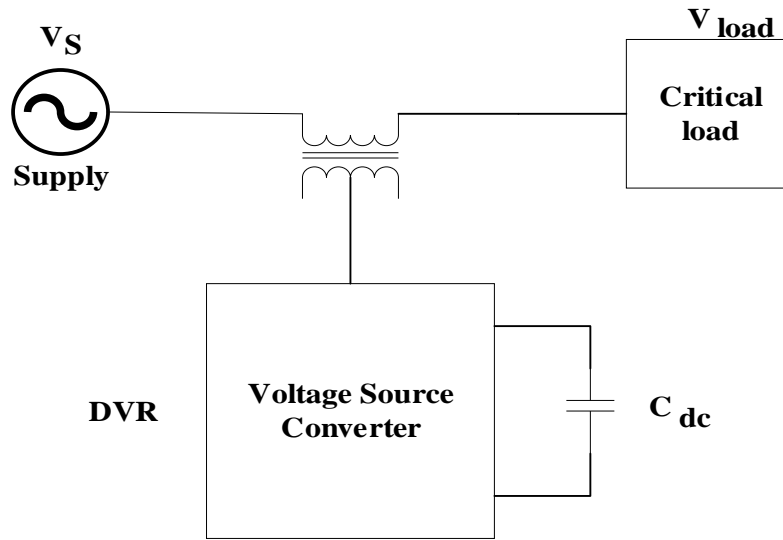

Fig. 1. (a) Basic circuit of DVR.

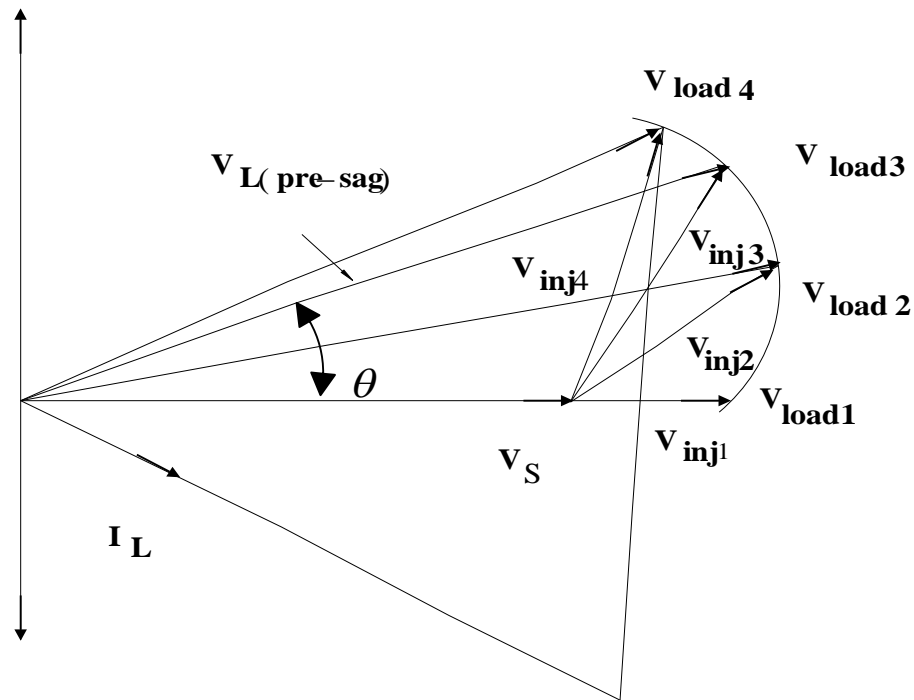

Fig. 1. (b) Phasor diagram of the DVR voltage infusion schemes.

V_{inj4} is where the infused voltage is in quadrature with the current, and this case is appropriate for capacitor-upheld DVR as this infusion includes no dynamic power. In any case, a minimum possible rating of the converter is accomplished by V_{inj1} .

III. CONTROL OF DVR

The compensation for sags employing a DVR should be possible by infusing or absorbing the real power or the reactive power [17]. Though, if the voltage infusion is in phase with current, DVR infuses real power, and therefore a battery is required at the dc bus of the VSC. While the voltage infusion is in quadrature with the current, at a fundamental frequency the compensation is done by reactive power infusion and the DVR is with a self-upheld dc bus. The control procedure embraced ought to consider the confinements, for example, the voltage infusion capacity (converter and transformer rating) and optimization of the span of energy storage.

A. Control of Capacitor-supported dvr for Voltage Sag and Swell Compensation

Fig. 3 signifies DVR mechanism which utilizes Synchronous reference frame (SRF) theory [23]. Source voltages of phase-a, phase-b and phase-c are transformed into dq0 reference frame using Park's transformation is as follows:

$$V_{Sd} = (2/3)(V_{Sa} \sin(\omega t) + V_{Sb} \sin(\omega t - 2\pi/3) + V_{Sc} \sin(\omega t + (2\pi/3))) \tag{1}$$

$$V_{Sq} = (2/3)(V_{Sa} \cos(\omega t) + V_{Sb} \cos(\omega t - 2\pi/3) + V_{Sc} \cos(\omega t + 2\pi/3)) \tag{2}$$

$$V_{S0} = (1/3)(V_{Sa} + V_{Sb} + V_{Sc}) \tag{3}$$

Load voltages (V_{La}, V_{Lb}, V_{Lc}) are changed over to the rotating reference frame $abc-dq0$ conversion utilizing Park's transformation with unit vectors ($\sin \theta, \cos \theta$) determined utilizing a phase-locked loop as

$$V_{Ld} = (2/3)(V_{La} \sin(\omega t) + V_{Lb} \sin(\omega t - 2\pi/3) + V_{Lc} \sin(\omega t + (2\pi/3))) \tag{4}$$

$$V_{Lq} = (2/3)(V_{La} \cos(\omega t) + V_{Lb} \cos(\omega t - 2\pi/3) + V_{Lc} \cos(\omega t + (2\pi/3))) \tag{5}$$

$$V_{L0} = (1/3)(V_{La} + V_{Lb} + V_{Lc}) \tag{6}$$

The reference load voltages in $dq0$ ($V_{Ldref}, V_{Lqref}, V_{L0ref}$) are given as

$$V_{Ldref} = (2/3)(V_{Laref} \sin(\omega t) + V_{Lbref} \sin(\omega t - 2\pi/3) + V_{Lcref} \sin(\omega t + (2\pi/3))) \tag{7}$$

$$V_{Lqref} = (2/3)(V_{Laref} \cos(\omega t) + V_{Lbref} \cos(\omega t - 2\pi/3) + V_{Lcref} \cos(\omega t + (2\pi/3))) \tag{8}$$

$$V_{L0ref} = (1/3)(V_{Laref} + V_{Lbref} + V_{Lcref}) \tag{9}$$

By using $dq0-abc$ transformation, the reference DVR voltages are given as

$$V_{dvra} = (V_{dvrdref} \sin(\omega t) + V_{dvraqref} \cos(\omega t) + V_{dvr0ref}) \tag{10}$$

$$V_{dvrb} = (V_{dvrdref} \sin(\omega t - 2\pi/3) + V_{dvraqref} \cos(\omega t - 2\pi/3) + V_{dvr0ref}) \tag{11}$$

$$V_{dvrc} = (V_{dvrdref} \sin(\omega t + 2\pi/3) + V_{dvraqref} \cos(\omega t + 2\pi/3) + V_{dvr0ref}) \tag{12}$$

The error amongst the reference and actual DVR voltages within the rotating reference frame is regulated, by discrete PWM generator.

Reference DVR voltages ($V_{dvra}, V_{dvrb}, V_{dvrc}$), actual DVR voltages ($V_{dvra}, V_{dvrb}, V_{dvrc}$) are used as a part of a Pulse width modulation (PWM) controller to produce pulses to VSC. The PWM controller is worked with an exchanging frequency of 10KHZ.

B. Configuration of three-phase three leg voltage source inverter:

The schematic diagram of Three-phase three leg VSI used in DVR is shown in Fig. 4. It consists of six power semiconductor switches each with antiparallel diode and two identical dc capacitors. This configuration is suggested in distribution system for the absence of dc component in load. This VSI configuration consists of less number of switches and three legs have independent control.

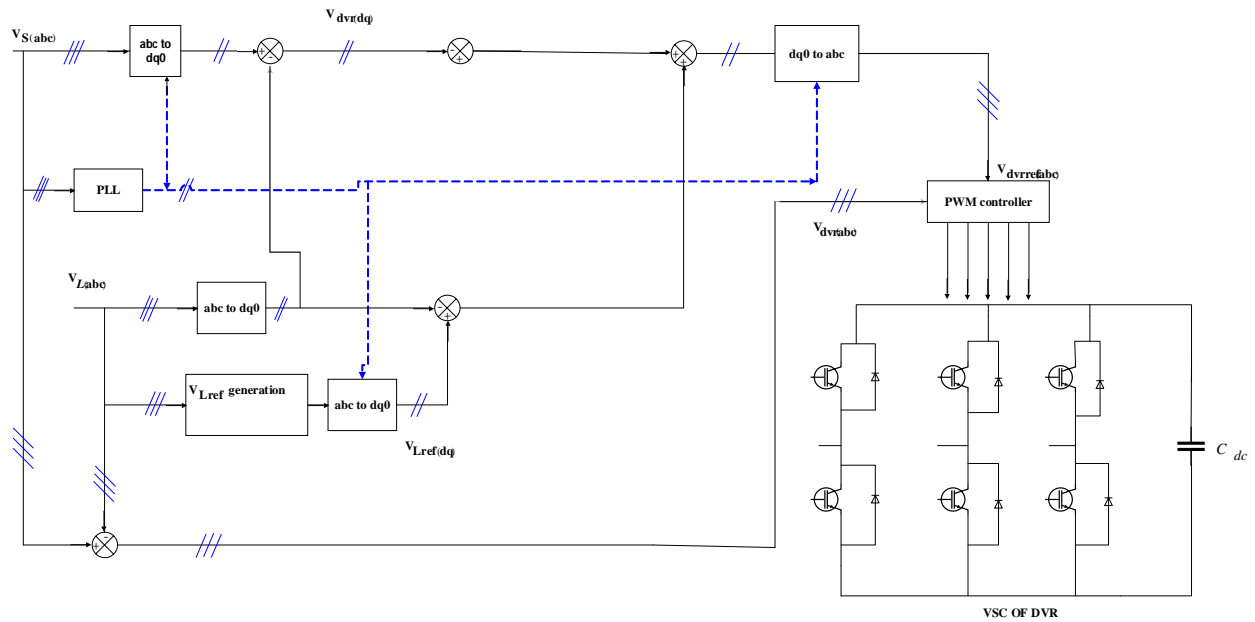

Fig. 3. Control block of the DVR that uses the SRF method of control.

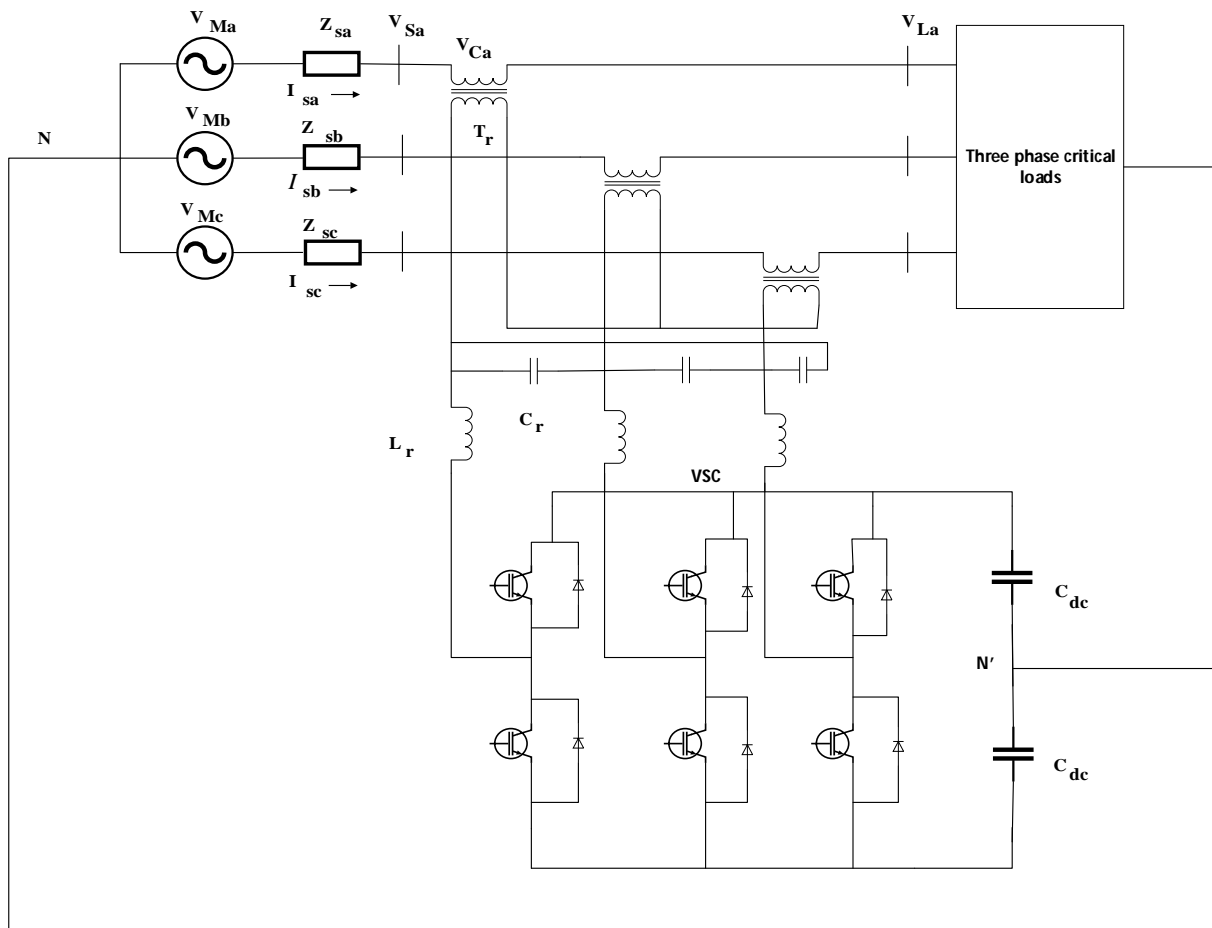

Fig. 4. Schematic of three-phase three leg DVR topology.

IV. DEMONSTRATING AND SIMULATION

The DVR connected system comprises of a three-phase supply, three phase critical loads, and the series infusion transformer plotted in Fig. 2 is demonstrated in MATLAB/SIMULINK with a sim control system tool compartment and is plotted in Fig. 5. An unbalanced load $phase - a, R = 150\Omega, L = 100mH, phase - b, R = 75\Omega, L = 100mH, phase - c, R = 50\Omega, L = 100mH$. taken. The Simulation study parameters are given in the appendix.

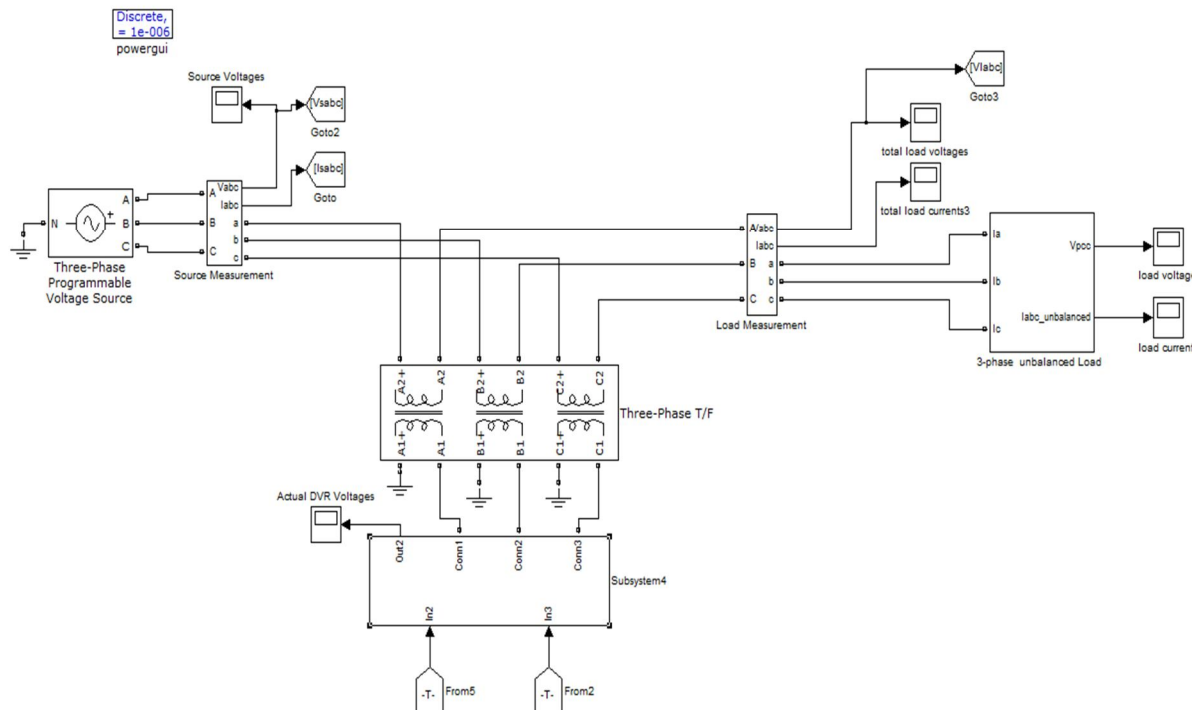

Fig. 5 MATLAB-based model of the Capacitor-upheld DVR-connected system.

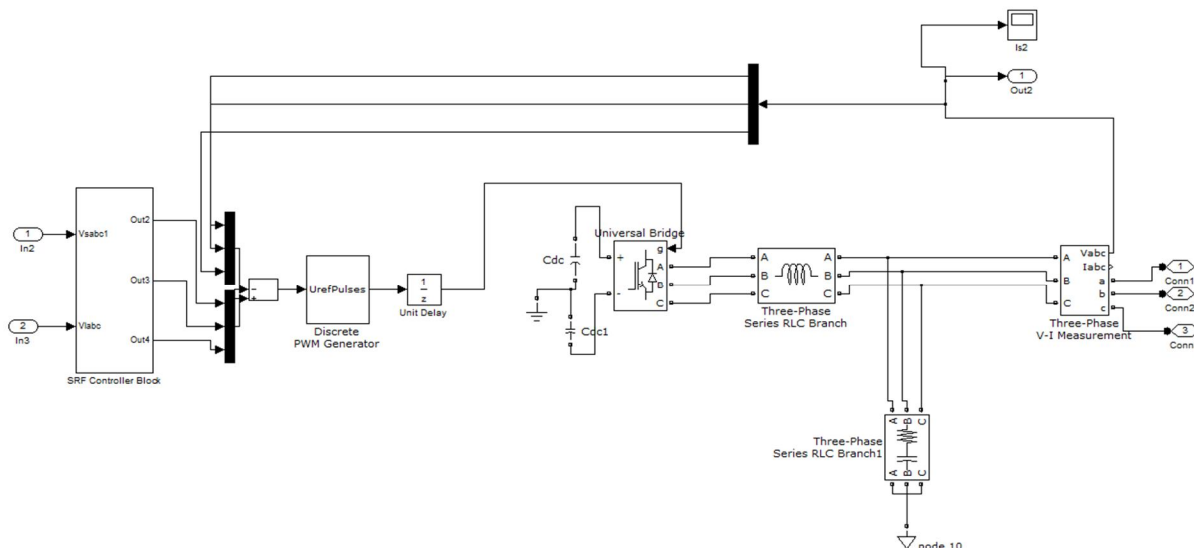

Fig. 6 Control block of DVR that uses SRF method of control.

From the Fig. 6 we can conclude that the actual and reference DVR voltages are regulated by the discrete PWM generator with a unit delay. The control calculation for the DVR is presented in Fig. 3 is likewise executed in MATLAB. The reference DVR

voltages are gotten from sensed PCC voltages (V_{sa}, V_{sb}, V_{sc}) and load voltages (V_{La}, V_{Lb}, V_{Lc}). A PWM controller is utilized over the sensed and reference DVR voltages to produce the gate signals to VSC. The capacitor – upheld DVR represented in Fig.4 is likewise executed in MATLAB.

V. PERFORMANCE OF THE DVR SYSTEM

The performance of DVR is clarified for various supply voltage disturbances, for example, voltage swell and dip. Fig. 7 (a) and Fig. 8(a) describes the transient performance of the system underneath swell and dip conditions. A swell in supply voltage is observed at 0.03-0.05 seconds with an excess magnitude of 80v and dip in the supply voltage is observed at 0.02-0.04 seconds with a decreased magnitude of 80V. The load voltages are plotted in Fig. 7 (c) and Fig. 8 (c) for both swell and dip conditions, which exhibits the in-phase Voltage infusion by DVR. The load voltage is kept up sinusoidal by injecting appropriate compensation voltage by the DVR.

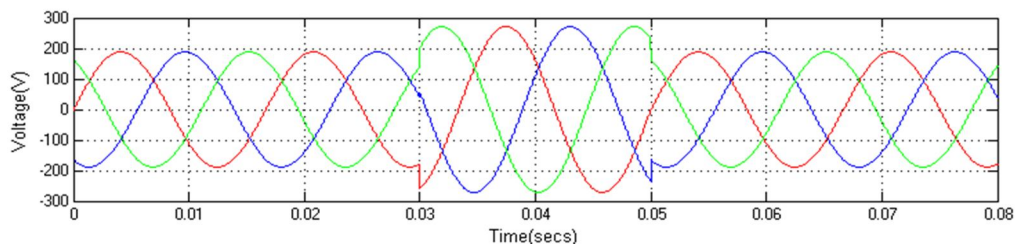

Fig. 7 (a) Performance of DVR during Voltage swell.

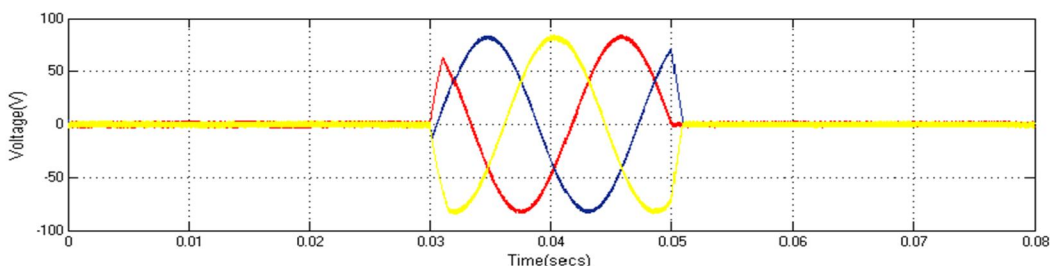

Fig. 7 (b) Voltage compensated by the DVR during swell.

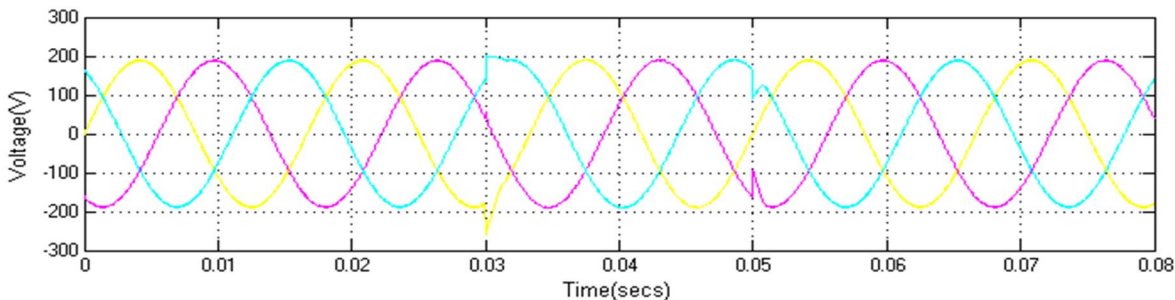

Fig. 7(c) Load voltage.

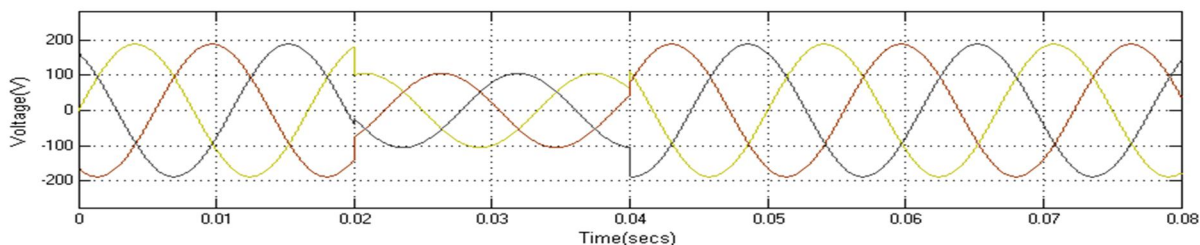

Fig. 8(a) Performance of DVR during voltage dip.

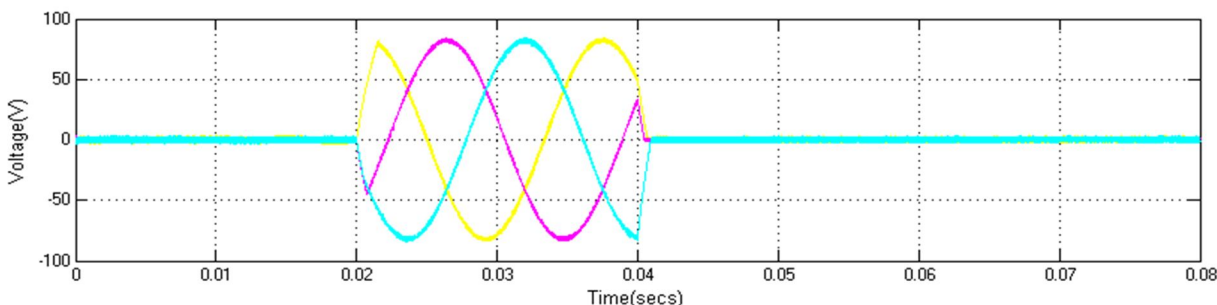

Fig. 8(b) Voltage injected by the DVR during dip.

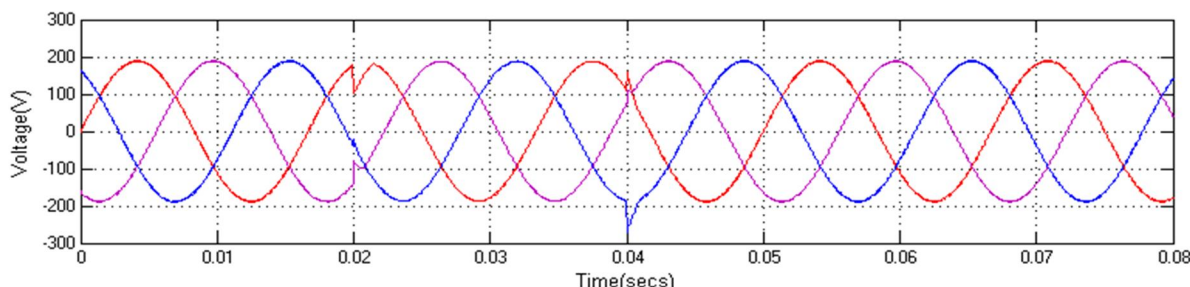

Fig. 8(c) Load voltage.

VI. CONCLUSION

The task of a DVR has been clarified with another control system utilizing different voltage infusion plans. A mechanism is proposed to control the capacitor upheld DVR. The mechanism of DVR is explained with a reduced rating VSC. Using the unit vectors, the reference load voltage is evaluated and the mechanism of DVR has been achieved, which limits the error of voltage injection. SRF theory is used to change the voltages from rotating vectors to the stationary frame. A correlation of the performance of the DVR with various plans has been performed with a reduced rating VSC including a capacitor upheld DVR. It is inferred that the Voltage infusion in phase with the PCC voltage brings about the minimum rating of DVR however at the cost of an energy source at its dc bus. From the simulation results it is concluded that mitigation of voltage dip and swell is achieved by using capacitor-upheld DVR.

APPENDIX

AC phase voltage	230V rms(Ph-Ph),60HZ
Un-balanced load	<i>phase – a</i> , $R = 150\Omega$, $L = 100mH$ <i>phase – b</i> , $R = 75\Omega$, $L = 100mH$ <i>phase – c</i> , $R = 50\Omega$, $L = 100mH$
Ripple filter values	$C_f = 1\mu F$, $R_f = 0.00002\Omega$, $L_f = 20mH$
PWM switching frequency	10KHZ
Series transformer	Three-phase transformer of rating 10000KVA,200V/200 V.
PLL gain	1/330

REFERENCES

- [1] M. H. J. Bollen, Understanding Power Quality Problems—Voltage Sags and Interruptions. New York, NY, USA:IEEE Press, 2000
- [2] P.Jayaprakash, B.Singh, D.P Kothari, A.chandra, Kamal al-Haddad, Control of Reduced –Rating Dynamic Voltage Restorer With a Battery Energy Storage system, IEEE TRANSACTIONS ON INDUSTRIAL APPLICATIONS, Vol. 50, No.2, MARCH/APRIL 20
- [3] M. H. J. Bollen and I. Gu, Signal Processing of Power Quality Disturbances. Hoboken, NJ, USA: Wiley-IEEE Press, 2006
- [4] A. Ghosh and G. Ledwich, Power Quality Enhancement Using Custom Power Devices. London, U.K.: Kluwer, 2002

- [5] A. Moreno-Munoz, *Power Quality: Mitigation Technologies in a Distributed Environment*. London, U.K.: Springer-Verlag, 2007
- [6] R. C. Dugan, M. F. McGranaghan, and W. Beaty, *Electric Power Systems Quality*, 2nd ed. New York, NY, USA: McGraw-Hill, 2006
- [7] IEEE Recommended Practices and Recommendations for Harmonics Control in Electric Power Systems, IEEE Std. 519, 1992
- [8] K. R. Padiyar, *FACTS Controllers in Transmission and Distribution*. New Delhi, India: New Age Int. , 2007.
- [9] S. Middlekauff and E. Collins, "System and customer impact," *IEEE Trans. Power Del.*, vol.13, no. 1, pp. 278–282, Jan. 1998.
- [10] V. B. Bhavraj and P. N. Enjeti, "An active line conditioner to balance voltages in a three-phase system," *IEEE Trans. Ind. Appl.* , vol. 32, no. 2, pp. 287–292, Mar./Apr. 1996.
- [11] J. G. Nielsen, F. Blaabjerg, and N. Mohan, "Control strategies for dynamic voltage restorer compensating voltage sags with phase jump," in *Proc. IEEE APEC*, 2001, vol. 2, pp. 1267–1273
- [12] M. Vilathgamuwa, R. Perera, S. Choi, and K. Tseng, "Control of energy-optimized dynamic voltage restorer, in *Proc. IEEE IECON*, 1999, vol. 2, pp. 873–87
- [13] A. Ghosh and A. Joshi, "A new algorithm for the generation of reference voltages of a DVR using the method of instantaneous symmetrical components," *IEEE Power Eng. Rev.*, vol. 22, no. 1, pp. 63–65, Jan. 2002
- [14] A. Ghosh and G. Ledwich, "Compensation of distribution system voltage using DVR," *IEEE Trans. Power Del.*, vol. 17, no. 4, pp. 1030–1036, Oct. 2002
- [15] E. C. Aeloíza, P. N. Enjeti, L. A. Morán, O. C. Montero-Hernandez, and S. Kim, "Analysis and design of a new voltage sag compensator for critical loads in electrical power distribution systems," *IEEE Trans. Ind. Appl.* , vol. 39, no. 4, pp. 1143–1150, Jul./Aug. 2003
- [16] I.-Y. Chung, D.-J. Won, S.-Y. Park, S.-I. Moon, and J.-K. Park, "The DC link energy control method in dynamic voltage restorer system," *Int. J. Elect. Power N Energy Syst.*, vol. 25, no. 7, pp. 525–531, Sep. 2003
- [17] A. Ghosh, A. K. Jindal, and A. Joshi, "Design of a capacitor supported dynamic voltage restorer for unbalanced and distorted loads," *IEEE Trans. Power Del.*, vol. 19, no. 1, pp. 405–413, Jan. 2004
- [18] J. W. Liu, S. S. Choi, and S. Chen, "Design of step dynamic voltage regulator for power quality enhancement," *IEEE Trans. Power Del.*, vol. 18, no. 4, pp. 1403–1409, Oct. 2003
- [19] J. G. Nielsen and F. Blaabjerg, "A detailed comparison of system topologies for dynamic voltage restorers," *IEEE Trans.*
- [20] A. Ghosh, "Performance study of two different compensating devices in a custom power park," *Proc. Inst. Elect. Eng.—Gener., Transm. Distrib.* , vol. 152, no. 4, pp. 521–528, Jul. 2005
- [21] A. K. Jindal, A. Ghosh, and A. Joshi, "Critical load bus voltage control using DVR under system frequency variation," *Elect. Power Syst. Res.* , vol. 78, no. 2, pp. 255–263, Feb. 2008
- [22] M. R. Banaei, S. H. Hosseini, S. Khanmohamadi, and G. B. Gharehpetian, "Verification of a new energy control strategy for dynamic voltage restorer by simulation," *Simul. Model. Pract. Theory*, vol. 14, no. 2, pp. 112–125, Feb. 2006
- [23] A. Chandra, B. Singh, N. Singh, and K. Al-Haddad, "An improved control algorithm of shunt active filter for voltage regulation, harmonic elimination, power factor correction, and balancing of nonlinear loads," *IEEE Trans. Power Electron.* , vol. 15, no. 3, pp. 495–507, May 2000
- [24] D. M. Vilathgamuwa, H. M. Wijekoon, and S. S. Choi, "A novel technique to compensate voltage sags in multilined distribution system—The interline dynamic voltage restorer," *IEEE Trans. Ind. Electron.* , vol. 53, no. 5, pp. 1603–1611, Oct.



10.22214/IJRASET



45.98



IMPACT FACTOR:
7.129



IMPACT FACTOR:
7.429



INTERNATIONAL JOURNAL FOR RESEARCH

IN APPLIED SCIENCE & ENGINEERING TECHNOLOGY

Call : 08813907089  (24*7 Support on Whatsapp)