



iJRASET

International Journal For Research in
Applied Science and Engineering Technology



INTERNATIONAL JOURNAL FOR RESEARCH

IN APPLIED SCIENCE & ENGINEERING TECHNOLOGY

Volume: 6 Issue: IV Month of publication: April 2018

DOI: <http://doi.org/10.22214/ijraset.2018.4354>

www.ijraset.com

Call:  08813907089

E-mail ID: ijraset@gmail.com

IOT Based Greenhouse Monitoring System

Rupali Satpute¹, Hemant Gaikwad², Shoaib Khan³, Aaditya Inamdar⁴, Deep Dave⁵

¹Professor, ^{2,3,4,5}Student, Department of Electronics and Telecommunication Engineering, K. J. Somaiya Institute of Engineering and Information Technology

Abstract: A greenhouse is a structure made mainly of transparent material, such as glass, in which plants are grown in a controlled environment. Traditional method of monitoring greenhouse involves human labour and is time consuming. The proposed system uses the concept of IOT (Internet of Things) and is much more efficient. The greenhouse environmental parameters are continuously sensed using various sensors and the collected data is displayed on a customized website. Thus, the greenhouse can be monitored from anywhere and at any time. The variation in individual sensor's data over time can be graphically plotted for improved monitoring and analysis.

Keywords: Internet of Things; Wi-Fi Module (ESP8266); Microcontroller (Arduino Uno); Sensors; Greenhouse Monitoring

I. INTRODUCTION

A greenhouse is mainly used to grow certain types of plants throughout the year or plants that require continuous monitoring to achieve high quality and quantity. At present most of the greenhouses are manually controlled and monitored. This method of greenhouse monitoring is labour intensive and time consuming. The Internet of Things concept can be used in greenhouse to increase the productivity by using various sensors to sense the environmental parameters. The Internet of Things is a network of devices that are connected via internet and together with web services communicate with each other. This paper proposes a system to monitor and automatically as well as manually control the system in greenhouse using temperature sensor, humidity sensor, light intensity sensor and soil moisture sensor. If the sensed data crosses a predefined threshold range an alarm will be triggered which will alert the user.

II. LITERATURE SURVEY

An overview of related research work has been presented in this section. Several authors have proposed using IOT concept in agriculture [1] and greenhouse [2]. K. Rangan and T. Vigneswaran [3] have described an embedded system approach for monitoring greenhouse based on parameters such as humidity, pH of water, wetness of soil, temperature and light intensity. These parameters are measured using sensors, processed, controlled and informed to the proprietor through Short Message Service technology using GSM modem. Prakash. H. Patil, Chaitali Borse, Snehal Gaikwad and Shilpa Patil [4] have developed a greenhouse monitoring system using GSM, which monitors the levels of temperature, humidity, light, and CO₂. Their proposed system uses sensors and Short Message Service technology. The system offers a mechanism to alert farmers regarding the parameter changes in the greenhouse. However, both systems lack a real-time graphical representation of the measured data and the feature of controlling the greenhouse system remotely. This paper mainly aims to describe the greenhouse monitoring system which will display the sensed data on a webpage and will also provide the facility of controlling and monitoring the system remotely.

III. PROPOSED MODEL

The greenhouse monitoring system uses various sensors to sense the environmental parameters of the greenhouse. The parameters used to monitor the greenhouse are temperature, humidity, light intensity and soil moisture. The data collected from the sensors are sent to the microcontroller for processing. The microcontroller is also connected to a Wi-Fi module which connects the system to the internet. After processing, the data is sent over the internet to be displayed on a customize webpage. A block diagram of the proposed system is presented in Fig. 1. The details of various components of the system are also provided.

A. Sensors

DHT 11 sensor is used to sense both temperature and humidity of the greenhouse. It requires only a single analog pin to send both temperature and humidity data. A soil moisture sensor is used to sense the moisture content of the soil and it also uses an analog to send the data to microcontroller. The light intensity in the greenhouse is measured by using an LDR sensor module.

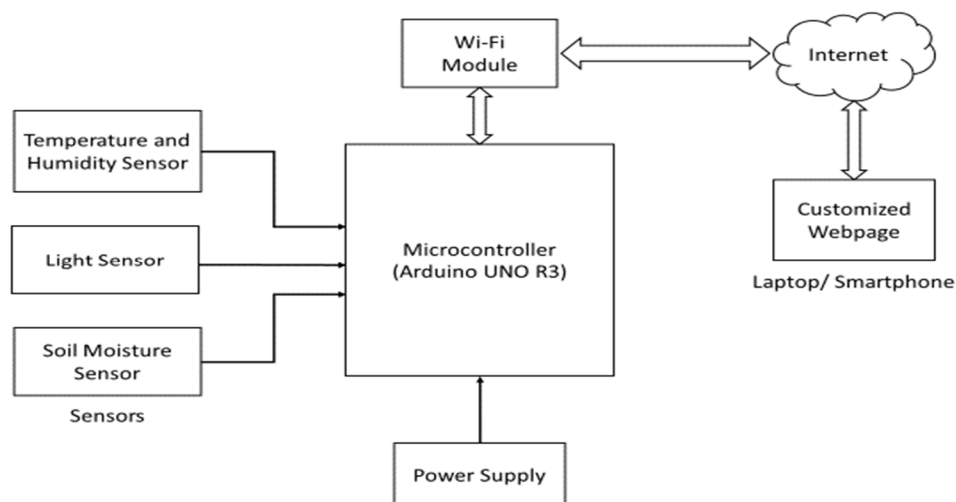

Fig. 1. Block Diagram of the Greenhouse Monitoring System

B. Microcontroller

The microcontroller used to design the greenhouse monitoring system is Arduino UNO R3. Arduino Uno is a microcontroller board based on the ATmega328P (datasheet). It has 14 digital input/output pins (of which 6 can be used as PWM outputs), 6 analog inputs, a 16 MHz quartz crystal, a USB connection, a power jack, an ICSP header and a reset button. It contains everything needed to support the microcontroller; simply connect it to a computer with a USB cable or power it with a AC-to-DC adapter or battery to get started [5].

C. Wi-Fi Module

ESP8266 Wi-Fi module is used to connect the greenhouse monitoring system to the internet. It is a low-cost Wi-Fi microchip with full TCP/IP stack and microcontroller capability produced by Shanghai-based Chinese manufacturer, Espressif Systems [6]. Due to its low price, it is the most popular Wi-Fi module used for Internet of Things projects.

IV. RESULT AND DISCUSSION

A hardware implementation of the greenhouse monitoring system was done. The parameters considered for monitoring the greenhouse were measured using the sensors and the data was updated on the customized webpage. A real time graph of the sensor values was also provided on the customized webpage which can be used for improved monitoring and analysis.

V. CONCLUSION

The proposed IOT based greenhouse monitoring system is a complete system designed to monitor and control the environmental parameters inside a green house. The traditional system for greenhouse monitoring is labour-intensive and time consuming. The proposed system saves time, money and human effort. It provides a controlled environment for the plants to prevent them from damage and thus increasing the overall produce. The smart greenhouse automatically controls the various parameters needed for the plants and sends the sensory data to a customized webpage for continuous and effective monitoring.

REFERENCES

- [1] Ji-chun Zhao, Jun-feng Zhang, Yu Feng, Jian-xin Guo, "The Study and Application of the IOT Technology in Agriculture", Computer Science and Information Technology (ICCSIT), 2010 3rd IEEE International Conference, 9-11 July 2010.
- [2] Cui Wenshun, Cui Shuo, Yuan Lizhe, Shang Jiancheng, "Design and implementation of sunlight greenhouse service platform based on IOT and cloud computing", 2nd International Conference on Measurement, Information and Control (ICMIC), August 2013, Vol. 01, pp. 141-144.
- [3] Rangan K. and T. Vigneswaran, "An Embedded systems approach to monitor greenhouse", IEEE Conference on Recent Advances in Space Technology Services and Climate Change (RSTSCC), 2010, pp. 61-65.
- [4] Prakash. H. Patil, Chaitali Borse, Snehal Gaikwad and Shilpa Patil, "Greenhouse Monitoring System Using GSM", International Journal of Scientific & Engineering Research, 2013, Vol. 4, Issue 6.
- [5] Arduino Uno Rev3. Available: <https://www.arduino.cc>
- [6] ESP8266 Overview. Available: www.espressif.com



10.22214/IJRASET



45.98



IMPACT FACTOR:
7.129



IMPACT FACTOR:
7.429



INTERNATIONAL JOURNAL FOR RESEARCH

IN APPLIED SCIENCE & ENGINEERING TECHNOLOGY

Call : 08813907089  (24*7 Support on Whatsapp)