



iJRASET

International Journal For Research in
Applied Science and Engineering Technology



INTERNATIONAL JOURNAL FOR RESEARCH

IN APPLIED SCIENCE & ENGINEERING TECHNOLOGY

Volume: 6 Issue: IV Month of publication: April 2018

DOI: <http://doi.org/10.22214/ijraset.2018.4793>

www.ijraset.com

Call:  08813907089

E-mail ID: ijraset@gmail.com

Design and Simulation of Power Converting Three-Phase to Multi-Phase Transformer

Aakansha Shrivastava¹, Manish Kurre², Lumesh Kumar Sahu³

^{1, 2, 3}Kalinga University

Abstract: Three phase supply is available in the generating station or grid, where as multi - phase supply is required for many industrial applications such as, aerospace, railway and automobile applications. There are different methods in which we can convert 3 to multi- phase using 18-Pulse Converter, Carrier Based PWM Technique, multilevel converter and Multiphase Transformer. The above said methods which are more complicated to design for higher ratings or a pure sine wave will not be obtained or harmonics will be more. For Multiphase power transmission system multiphase transformers are needed. In the multiphase power transmission and multiphase rectifier systems, the number of phase can be designed and developed in multiples of three. Therefore, the variable speed multiphase drive system considered in the literature are mostly of five, seven, multi -, eleven, twelve, and fifteen phase. So, there is a need to design and develop special transformer which converts from 3 to multi- phase for different arrangement of input and output. Thus, with the proposed technique, a pure multi --phase sine-wave of fixed voltage/current and frequency is obtained, which can be used for RL load and motor testing purposes. Complete design and simulation of the proposed solution is presented. Analytical calculation and simulation results for RL load is presented in the paper. This model can be simulated by using MATLAB/SIMULINK software.

Keywords: multi winding transformer, multiphase transmission, three-to-multi - phase

I. INTRODUCTION

The use of no of phase systems compared to three phase systems has brought about researchers interest. The application of multiphase systems is explored in electric power generation, transmission and utilization. The research on multiphase generators has recently started. The research on multiphase drive systems has been significantly developed since the beginning of this century due to advancement in semiconductor devices and digital signal processors technologies. It is to be emphasized here that ac/dc/ac converters generally supply the multiphase motors. Thus, the focus of the current research on multiphase electric drives is limited to the modeling and controlling of the power converters. Little effort is being made to develop static multi winding transformation system to change the phase number from three-to-multi-phase. An exception is where a new type of transformer is presented, which is three phase-to-multi --phase system. The analysis and design, however, are completely different. The fixed 3-phase voltage and fixed frequency available in grid power supply can be transformed to fixed voltage and fixed frequency multi-phase output supply. By connecting a three phase auto transformer at the input side , we can get variable output voltage .In this paper, the input and output supply can be arranged in the following manners: 1) Input star, output star. 2) Input star, output nonagon. 3) Input delta, output star. 4) Input delta, output nonagon

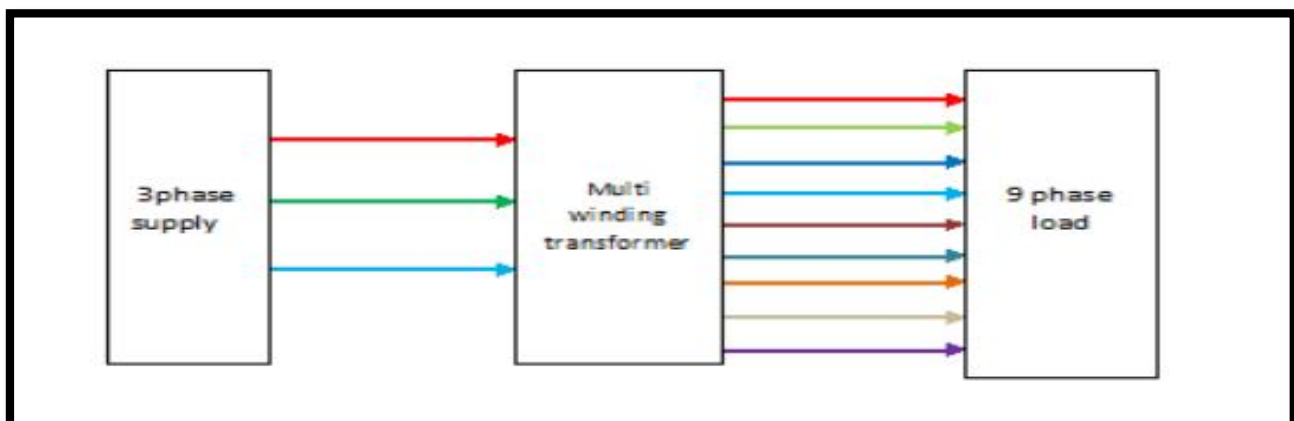

A. Winding Arrangement For Multi-Phase

Three separate cores are designed with each of them carrying one primary coil and five secondary coils, are wound. 6 terminals of primaries are connected in an appropriate manner resulting in star/delta connections, and the 30 terminals of secondaries are connected in a different fashion resulting in a star/nonagon output. The connection scheme of secondary windings to obtain input star and output star is illustrated in Figs. 1 and 2 and the corresponding phasor diagram is illustrated in Fig. 3. Similarly for input delta and output star connection is also shown in the fig 4, 5 and 6.

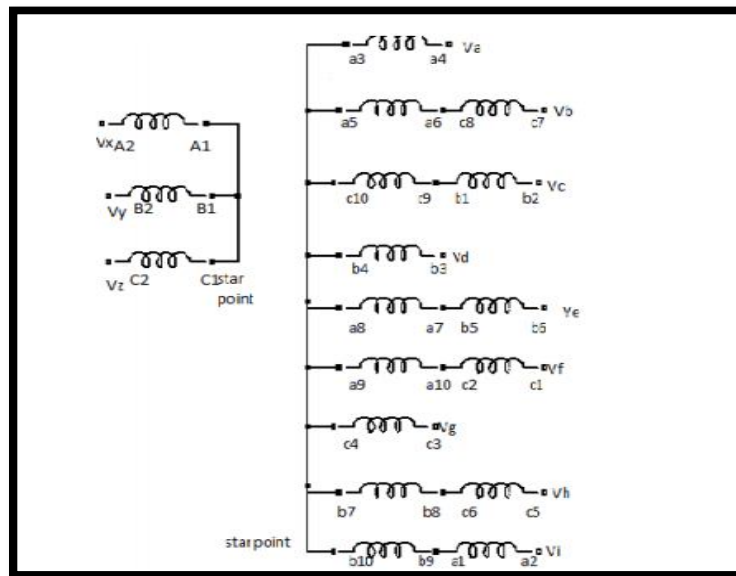

Fig. I. Proposed transformer winding connection (star-star).

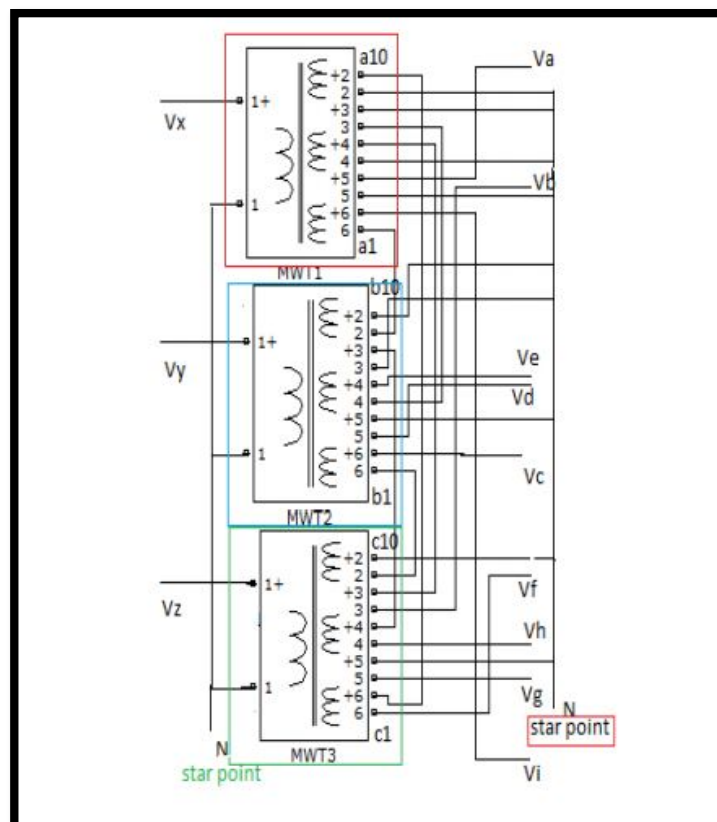

Fig: II proposed winding arrangement (star-star)

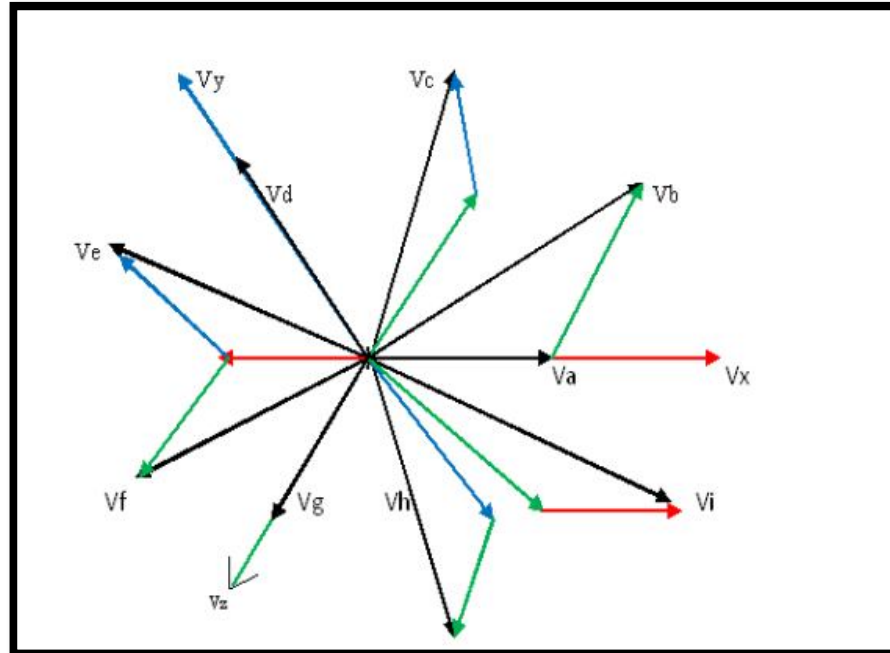

Fig III. Phasor diagram of the proposed transformer connection (starstar).

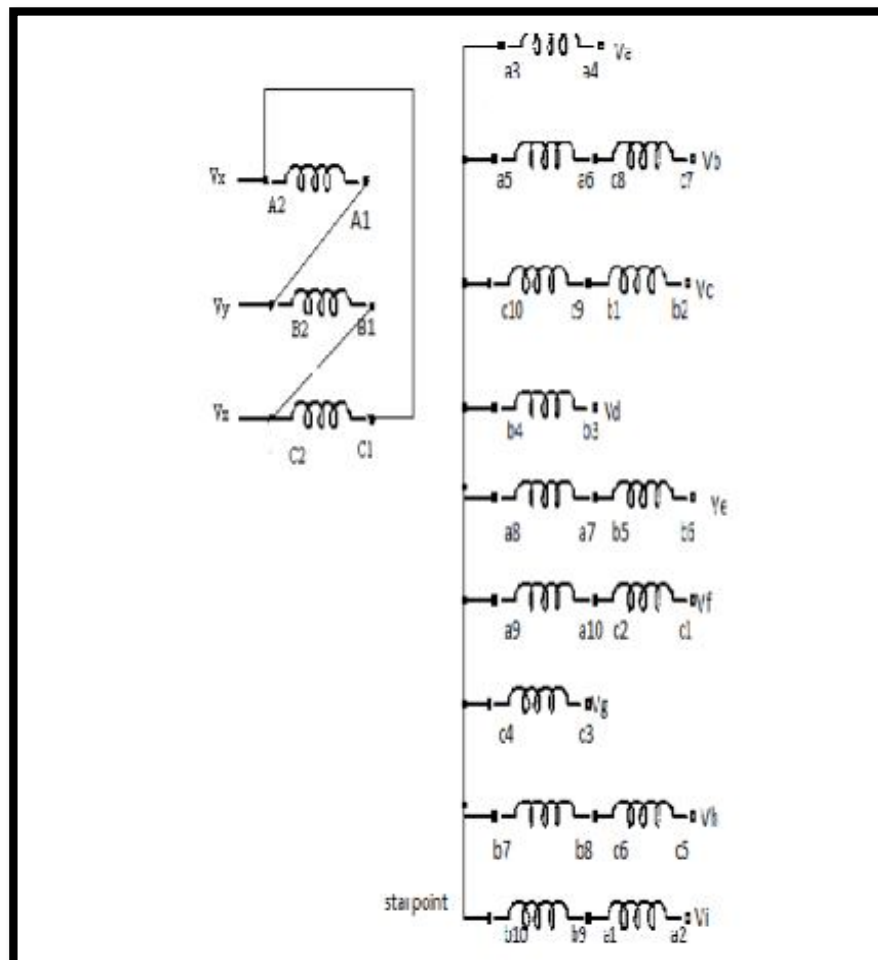

Fig IV Proposed transformer winding connection (delta-star).

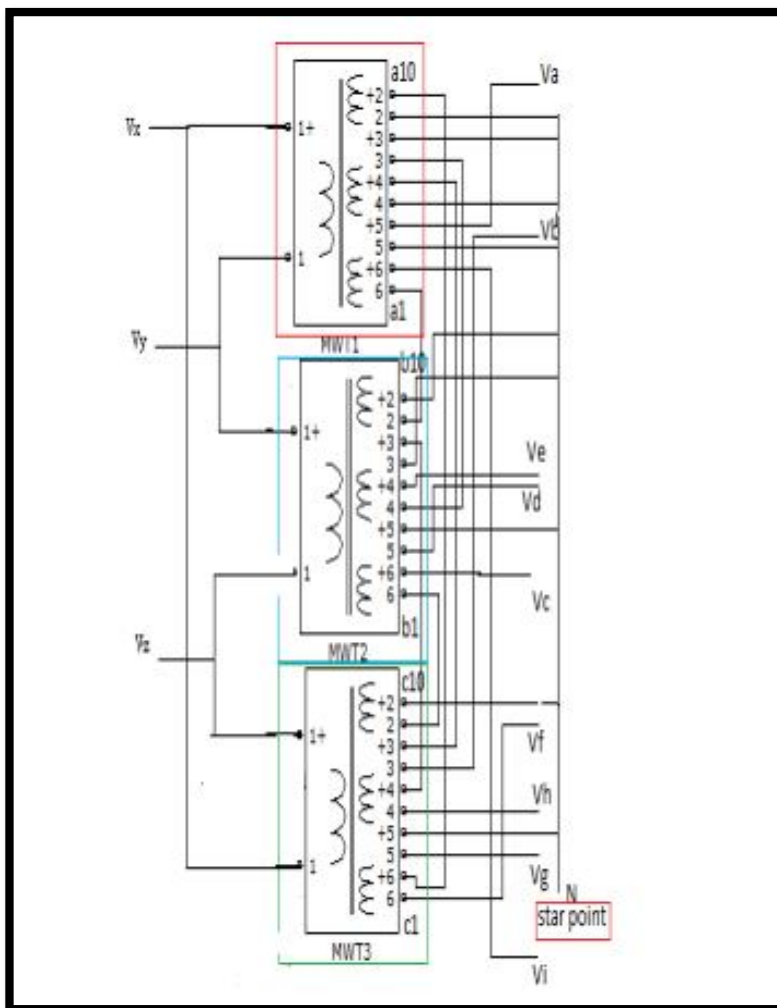

Fig V proposed winding arrangement (delta-star)

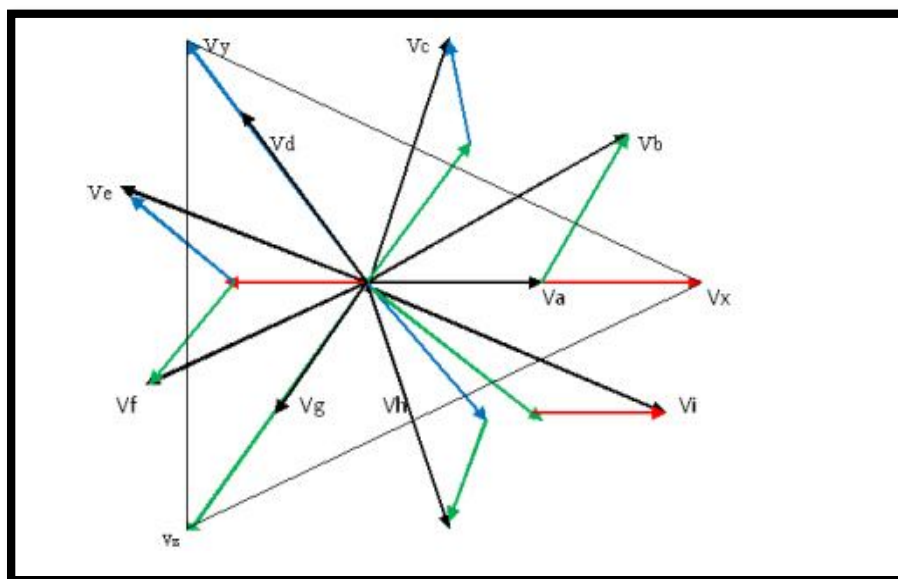

Fig VI Phasor diagram of the proposed transformer connection (delta-star).

II. SIMULATION RESULTS

The designed transformer is at first simulated using —Sim-Power Systeml block sets of the MATLAB/Simulink software. From sim-power system block library, multi winding block is chosen and the correct turn ratios are set in the dialog box and the simulation is run. Turn ratios are given in Table I. The resulting input and output voltage waveforms are given in Fig 10 to 14 for star-star and delta star. It is seen that the output is a balanced multi - phase supply for a balanced three-phase input. The output will be unbalanced if the input is unbalanced. Individual output phases are also shown along with their respective input voltages and equations. The 3-phase output from a multi-phase input supply can also be obtained in similar fashion.

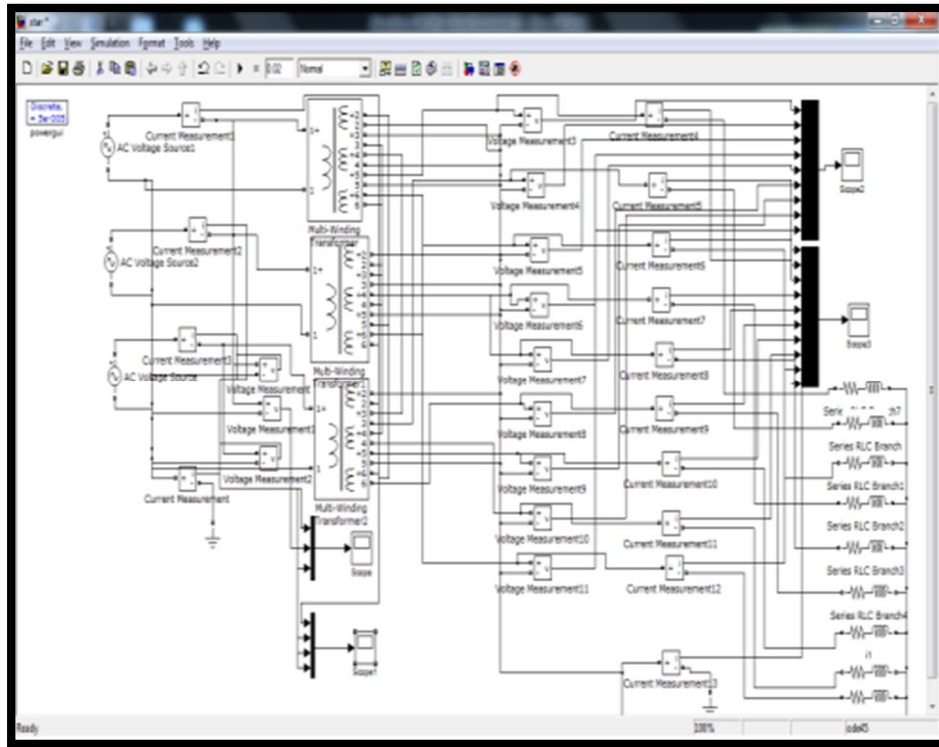

Fig VII shows the simulation circuit for star-star connection

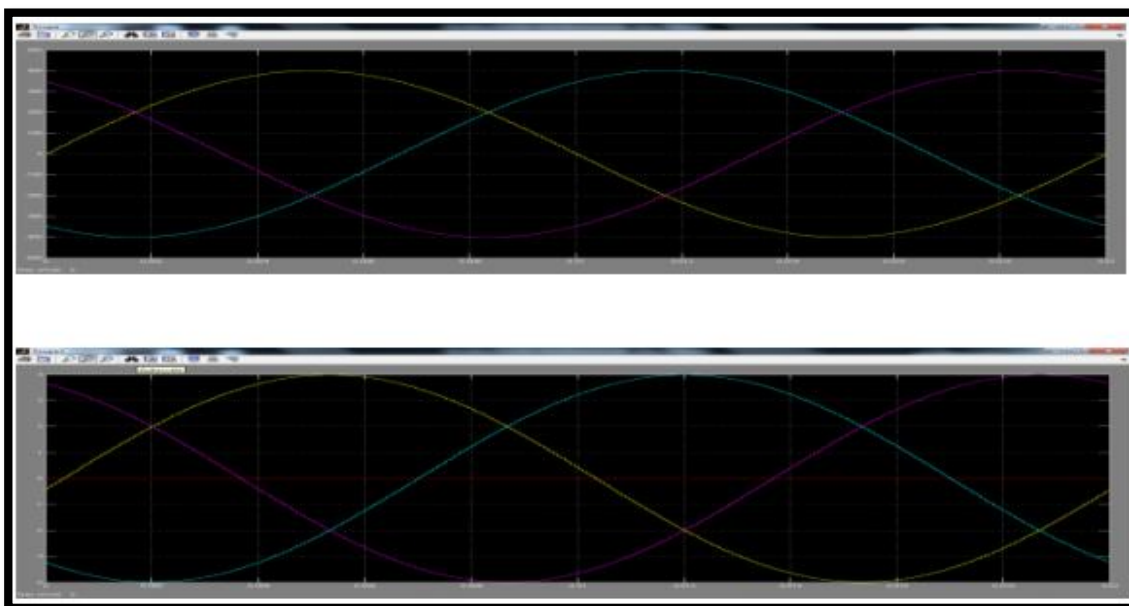

Fig :VIII shows the input voltage and current wave forms

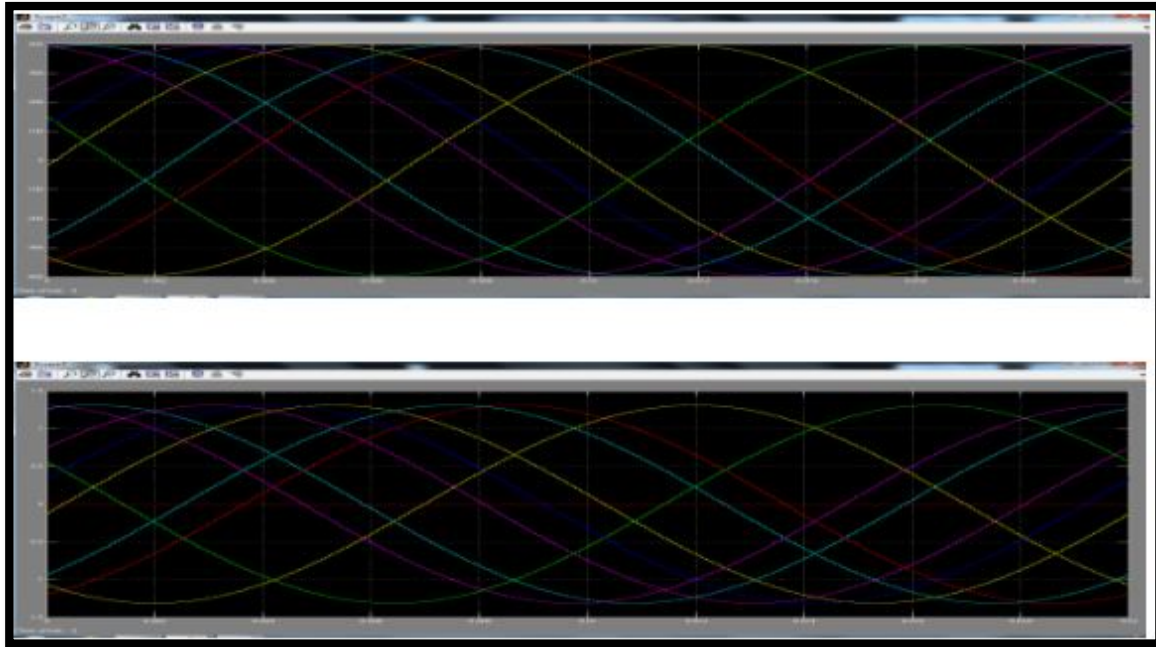

Fig IX shows the output voltage and current waveforms

III. CONCLUSION

This paper gives a new method to convert 3 phase to multi- phase using special transformer connection. The winding arrangement and the vector diagram, along with the turn ratios, are given in the table. The successful implementation of the proposed connection scheme is elaborated upon using simulation of mat-lab software using sim power system blocks. The proposed connection scheme can be used in drives and other multiphase applications. By using the same method we can also get the nonagon output.

REFERENCES

- [1] D. Basic, J. G. Zhu, and G. Boardman, —Transient performance study of brushless doubly fed twin stator generator,| IEEE Trans. Energy Convers.,vol. 18, no. 3, pp. 400–408, Sep. 2003.
- [2] G.K. Singh, —Self excited induction generator research—A survey,| Elect.Power Syst. Res., vol. 69, pp. 107–114, 2004.
- [3] O. Ojo and I. E. Davidson, —PWM-VSI inverter-assisted stand-alone dual stator winding induction generator,| IEEE Trans. Energy Convers., vol. 36, no. 6, pp. 1604–1611, Nov./Dec. 2000.
- [4] G. K. Singh, K. B. Yadav, and R. P Sani, —Analysis of saturated multiphase(six-phase) self excited induction generator,| Int J. Emerg. Electr.Power Syst., vol. 7, no. 2, article 5, Sep. 2006
- [5] G. K. Singh, —Modelling and experimental analysis of a self excited sixphaseinduction generator for stand alone renewable energy generation,| Renewable Energy, vol. 33, no. 7, pp. 1605–162, Jul. 2008.
- [6] J. R. Stewart and D. D.Wilson, —High phase order transmission—A feasibilityanalysis—Part-I: Steady state considerations,| IEEE Trans. PowerApp. Syst., vol. PAS-97, no. 6, pp. 2300–2307, Nov. 1978.
- [7] J.R. Stewart andD.D.Wilson, —High phase order transmissionAfeasibilityanalysis—Part-II: Over voltages and insulation requirements,| IEEETrans. Power Ap. Syst., vol. PAS-97, no. 6, pp. 2308–2317, Nov. 1978.
- [8] J. R. Stewart, E. Kallaur, and J. S. Grant, —Economics of EHV high phaseorder transmission,| IEEE Trans. Power App. Syst., vol. -PAS 103, no. 11,pp. 3386–3392, Nov. 1984.
- [9] S. N. Tewari, G. K. Singh, and A. B. Saroor, —Multiphase Power transmissionresearch—A survey,| Electr. Power Syst. Res., vol. 24, pp. 207–215,1992.
- [10] C. M. Portela andM.C. Tavares, —Six-phase transmission linepropagation characteristics and new three-phase representation,| IEEE Trans. Power Delivery, vol. 18, no. 3, pp. 1470–1483, Jul. 1993.
- [11] T. L. Landers, R. J. Richeda, E. Krizanskas, J. R. Stewart, and R. A. Brown, —High phase order economics: Constructing a new transmission line,|IEEE Trans. Power Delivery, vol. 13, no. 4, pp. 1521–1526, Oct. 1998.



10.22214/IJRASET



45.98



IMPACT FACTOR:
7.129



IMPACT FACTOR:
7.429



INTERNATIONAL JOURNAL FOR RESEARCH

IN APPLIED SCIENCE & ENGINEERING TECHNOLOGY

Call : 08813907089  (24*7 Support on Whatsapp)