



IJRASET

International Journal For Research in
Applied Science and Engineering Technology



INTERNATIONAL JOURNAL FOR RESEARCH

IN APPLIED SCIENCE & ENGINEERING TECHNOLOGY

Volume: 6 Issue: VI Month of publication: June 2018

DOI: <http://doi.org/10.22214/ijraset.2018.6131>

www.ijraset.com

Call:  08813907089

E-mail ID: ijraset@gmail.com

Injecting the Compensating Voltage to the System using DVR

Deepak kumar Dhurwey¹, Dr. Arvind kumar Sharma²

^{1,2}Department Of Electrical Engineering, Jabalpur Engineering College, Jabalpur

Abstract: *The dynamic voltage restorer is one of the power electronic based device. It is also known as the custom power device which is used in the distribution system. It is used for the protection of household and industrial electrical devices against sudden changes in the amplitude of voltage, mainly voltage sag and voltage swells. The DVR works in such a manner by injecting the compensating voltage to the system where the disturbance or fault has occurred DVR can inject up to 50% of the nominal voltage to the system. In this paper, the analysis on DVR is done, and also its functions are explained. Simulation results are also being shown and compared to each other to find out and examine the capability and usefulness of the controlled structure.*

Keywords: *Dynamic voltage restorer, Voltage Sag, Voltage Swell.*

I. INTRODUCTION

The maintenance of good power quality is one of the most important issue now-a-days and the consumers as well as the electrical suppliers are very much concerned about about the issue of power quality. This matter has obtained a large attention in the past few years. Since most of the electrical equipments used today are very sensitive and may get damaged due to interruption during poor power quality events. Such poor power quality events mostly happen during the condition when fault occurs, for example the lightning strokes. Such faults unpropitiously create an impact on line-voltage and the current waveforms. This may further affect the operation and efficiency of the electrical equipments.

Power Quality can be defined as the study of powering and grounding electronic systems so as to maintain the integrity of the power supplied to the system. It can also be defined as the concept of powering and grounding the electronic equipments in such a manner that is suitable for the operation of that equipment.

Nevertheless, a good power quality cannot be defined so easily. This is because, all the equipments do not require the same type of power quality. The type of power quality varies from one equipment to the other. However, power quality is basically the amalgamation of current quality and voltage quality, which involves the interaction between the system and the load connected. Here the voltage quality implies to the fluctuation or variation of the voltage waveform from ideal sinusoidal voltage waveform. It involves the performance of the system to the load, whereas current quality involves the operation load towards the power system. But actually, the voltage quality is the major issue of concern in the power quality in most of the cases. The equipments in our power system are designed to operate at a sinusoidal voltage having frequency of 50 or 60 Hz and magnitude. If any noteworthy irregularity or fluctuation is present in the waveform, frequency or magnitude, then there is a potential power quality problem in the system. The poor power quality usually shows the deviation in the voltage waveform from that of the ideal voltage waveform of the same device. Hence, the power distribution systems, should ideally supply an uninterrupted power flow to their customers. Some of the disturbances which occur in the voltage waveform are as follows-

A. Voltage Sag

Voltage Sag can be defined as the temporary or momentary decrease in the root mean square (RMS) voltage ranging between 0.1 to 0.9 per unit. The duration of the voltage sag is half cycle to 1 minute. It can also be defined as the voltage sag occurs when the RMS voltage diminishes between 10 and 90 percent of nominal voltage for one half cycle to 1 minute.

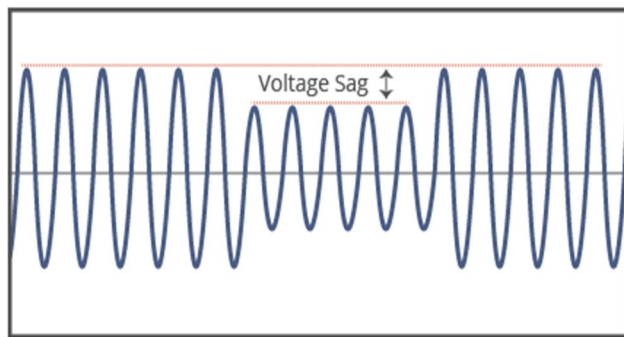

Figure.1.

Figure.1 shows the waveform of voltage sag. It is considered as the most serious problem of power quality. It is also known as voltage dip. There are various factors due to which voltage sag is caused. Some of them are listed below-

- 1) *Large Electric Motors*- The large electric motors draw a large amount of current when they are starting as compared to when they are running. Therefore, voltage sag is occurred due to the electric motors
- 2) *System Faults*- When the line-to-ground faults occur, there is always a possibility of occurrence of voltage sag. For example- single line to ground faults.
- 3) *Load Energization*- Sudden energization of heavy loads reduce the voltage because of which voltage sag occurs. Voltage sags appear from the utility and this could be experienced by us at our residence when the air conditioner, refrigerator or fan start-up.

B. Voltage Swell

Voltage Swell is just opposite to that of voltage sag. It can be defined as the momentary increase in root mean square (RMS) voltage from 1.1 to 1.8 per unit of the nominal line voltage for the duration of half cycle to one minute.

Voltage swell wave form

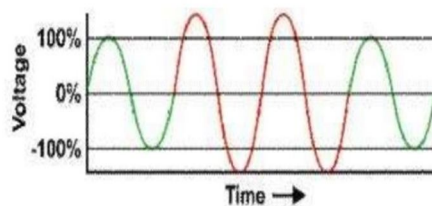

Figure.2.

Figure.2 shows the waveform of voltage swell. It is not important as compared to the voltage sag. This is because they occur very less and are not much popular as that of the voltage sag. There are various factors due to which voltage swells are caused. They are listed below-

- 1) *Large Capacitors*- Switching of large capacitors (capacitor energizing) causes voltage swell.
- 2) *Single line to ground fault*- During the single line to ground faults, there is a probability of occurrence of voltage swell
- 3) *Large Loads*- Due to switching off a large load voltage swell can occur.
- 4) *Tap Changer*- Incorrect settings of tap changer causes swells. Due to the voltage swell, the electrical equipment mal-operates and this voltage instability is undesirable to the power system.

C. Solution To The Power Quality Problems

There are two ways in which the problems of voltage sag and swell can be resolved. The first step could be taken from the customer's side or the actions could be taken from the utility side. The first approach is known as the "load conditioning". In his approach electrical equipment is made certain in such a manner that is less susceptible to the disturbances or faults, further allowing the operation even under considerable voltage distortion. The second approach is known as the "line conditioning". In the line conditioning system's utility side plays a very important role in the improvement of the power quality. The devices used in the line

conditioning system are the custom power devices. There are various types of custom power devices, the device which is discussed in this paper is the Dynamic Voltage Restorer (DVR). The simulation model is developed using MATLAB SIMULINK and the output results are also discussed.

D. Dynamic Voltage Restorer

The Dynamic Voltage Restorer (DVR) is a series connected voltage sourced converter based custom power device which is designed to protect the sensitive electrical equipments from voltage sag and swells in the power distribution network. The term custom power device refers to the use of power electronic controllers in the distribution system. Hence, DVR is the power electronic converter based solid state device. It is one of the most efficient and modern custom power device used in the distribution system. The first DVR was installed in North America in the year 1996 at a 12.47 kV system located in Anderson, South Carolina. The basic operating principle of DVR is to inject voltage of the required magnitude and frequency, so that system can restore the load side voltage to the desired amplitude and waveform even when the source voltage is unbalanced or distorted. DVR is installed in a distribution system between the supply and the critical load feeder. It can inject up to 50% of the nominal voltage. The maximum voltage that could be injected by the DVR can be determined by the energy storage unit and the voltage injection transformer ratio. Therefore, DVR allows successfully to provide protection against voltage sag condition.

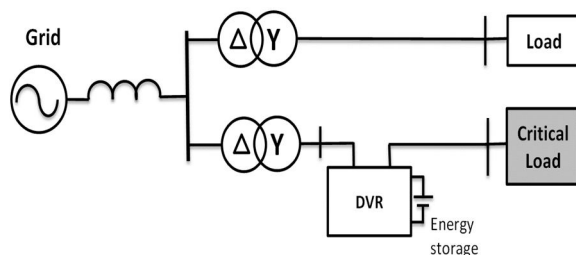

Figure.3.

The above figure shows the location of DVR.

E. General Configuration Of Dvr

The basic components of Dynamic Voltage Restorer (DVR) consists of following parts-

- 1) Injection or Booster Transformer
- 2) Harmonic Filter
- 3) Voltage Source Inverter
- 4) Energy Storage Unit
- 5) Control System

The brief description of all above mentioned components is as follows-

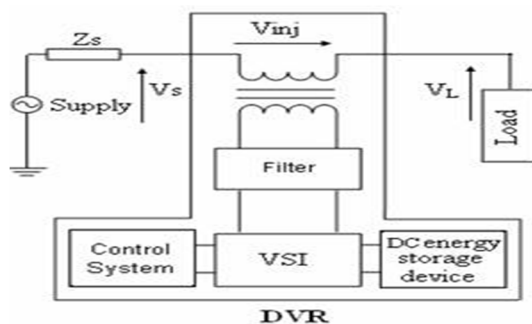

Figure.4.

Figure.4 shows the basic components of Dynamic Voltage Restorer (DVR).

- 6) *Injection or Booster Transformer:* The basic function of Injection or Booster Transformer is to connect the DVR to the distribution network through the HV winding and transform and also to couple the injected compensating voltage generated by the voltage source inverter in series with the incoming supply voltage. Booster Transformer also isolates the load from the system. The low voltage winding of this transformer is connected to the power circuit of DVR.
- 7) *Harmonic Filter:* This is used or the elimination and reduction of harmonic content present in the system which is generated by the voltage source inverter (VSI).
- 8) *Voltage Source Inverter:* The Voltage Source Inverter is used for the conversion of DC voltage (which is supplied by the energy storage unit) to the AC voltage. The voltage source inverter is power electronic device which can generate a sinusoidal waveform at a desired frequency and magnitude.
- 9) *Energy Storage Unit:* This is used to supply the real power requirements of the system for compensating the voltage during the period of voltage sag. Here the energy is stored in the DC form. Some of the devices used for the energy storage are flywheels, batteries, super capacitors, etc. Energy storage unit is the most expensive part of DVR.
- 10) *Control System:* The control system is used or maintaining the constant voltage magnitude near the sensitive load during the time when the disturbance (voltage sag) occurs.

V. SIMULATION RESULTS

Modelling and simulation are performed on the transmission line in which the DVR is connected. The model is shown below in figure.5.

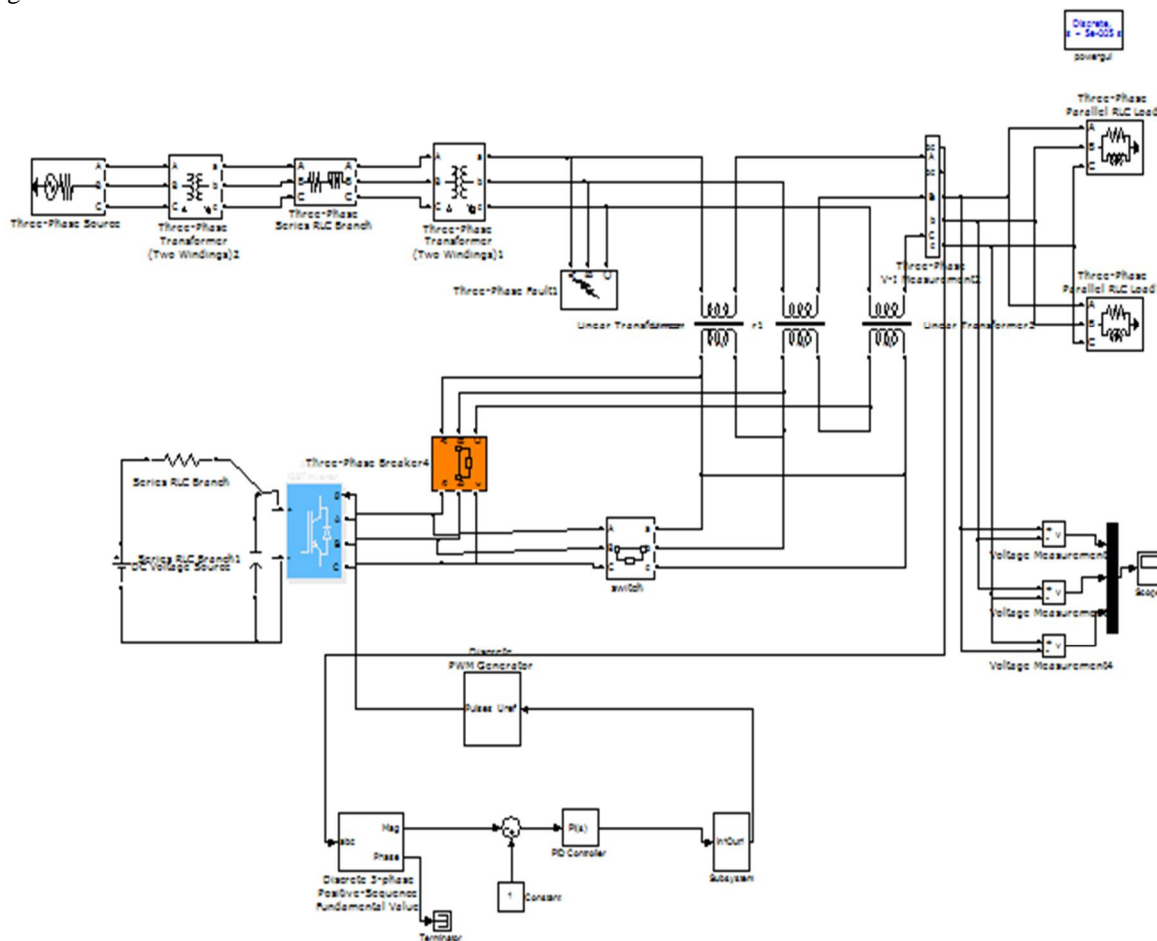

Figure.5.

A small part of a transmission line is taken into consideration and the simulation is performed using MATLAB. The output waveforms obtained are as follows-

A. When the DVR is not connected from the system, the voltage sag can be seen in the output waveform.

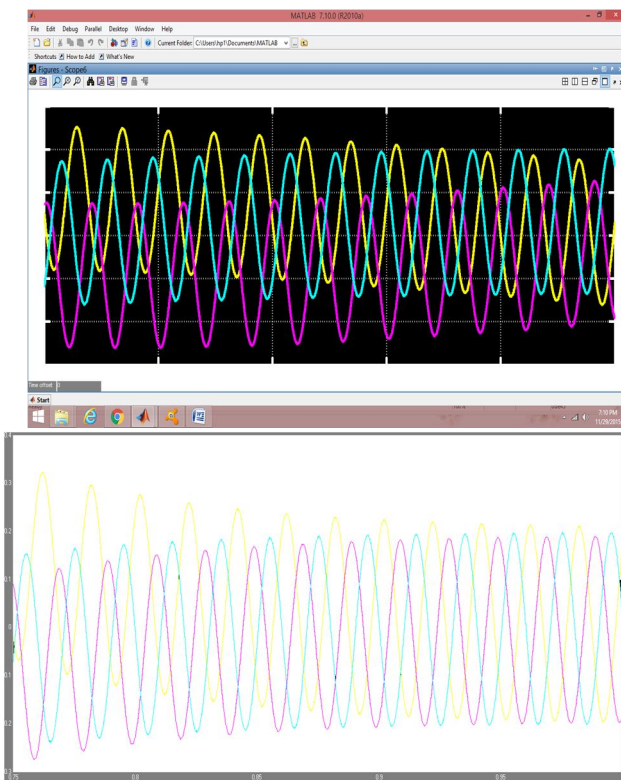

Figure.6.

The above waveforms in figure.6 shows the condition of voltage sag.

B. When the DVR is connected to the system, therefore, the voltage sag is eliminated from the system. Hence the output waveform do not contain voltage sag.

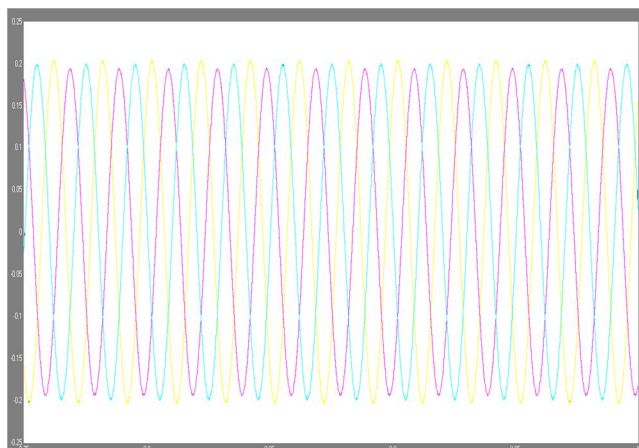

Figure.7.

The above waveforms in figure.7 shows the normal output waveform without having voltage sag.

VI. CONCLUSION

In this paper the characterization of DVR is done. The basic components of DVR are explained along with the power quality and the major power quality problems with the help of simulation results. It is concluded that the Dynamic Voltage Restorer is the most efficient custom power device which can be used for the compensation of voltage during the disturbance occurs.



REFERENCES

- [1] Shazly A. Mohammed, Aurelio G. Cerrada, Abdel-Moamen M. A, and B. Hasanin, "Dynamic Voltage Restorer (DVR) System for Compensation of Voltage Sag, State-of-the -Art Review."
- [2] T.Sundar and S.Sankar, "Simulation and Investigation of Prototype DVR for Power Flow Control."
- [3] C. Benachaiba, and B. Ferdi "Voltage quality improvement using DVR", Electrical Power Quality and Utilization, Journal Vol. XIV, No. 1, pp. 39-45, 2008
- [4] R. Ibrahim, A. M. Haidar, M. Zahim "The Effect of DVR Location for Enhancing Voltage Sag" Proceedings of the 9th WSEAS International Conference on Applications of Electrical Engineering, pp. 92-98
- [5] Anita Pakharia, Manoj Gupta, "DVR Based Compensation of Voltage Sag due to Variations of Load: A Study on Analysis of Active Power."
- [6] M. Izhwan M, N. Mariun, and M. Amran M. Radzi, "The effect of Power Quality to the industries", The 5th SCORED, Dec. 2007, Malaysia, pp. 1- 4
- [7] P. T. Nguyen, Tapan. K. Saha, "Dynamic Voltage Restorer against Balanced and Unbalanced Voltage Sags: Modelling and Simulation," IEEE Power Engineering Society General Meeting, vol. 1, pp. 639-644, June 2004
- [8] Anita Pakharia, Manoj Gupta, Dynamic Voltage Restorer for Compensation of Voltage Sag and Swell: A Literature Review."
- [9] V. S. Mallela, P. S. Solanki, and A. Chaturvedi "Role of a Dynamic Voltage Restorer in Mitigation of Power Quality Problems" International Conference on Communication, Computer & Power (ICCCP'05), Feb. 2005, pp. 161- 166
- [10] E. Babaei, M. F. Kangarlu,"A New Topology for Dynamic Voltage Restorers without dc Link" IEEE Symposium on Industrial Electronics and Applications (ISIEA 2009), October 4-6, 2009, Kuala Lumpur, Malaysia.



10.22214/IJRASET



45.98



IMPACT FACTOR:
7.129



IMPACT FACTOR:
7.429



INTERNATIONAL JOURNAL FOR RESEARCH

IN APPLIED SCIENCE & ENGINEERING TECHNOLOGY

Call : 08813907089  (24*7 Support on Whatsapp)