



# **iJRASET**

International Journal For Research in  
Applied Science and Engineering Technology



---

# **INTERNATIONAL JOURNAL FOR RESEARCH**

IN APPLIED SCIENCE & ENGINEERING TECHNOLOGY

---

**Volume: 7      Issue: II      Month of publication: February**

**DOI: <http://doi.org/10.22214/ijraset.2019.2092>**

**[www.ijraset.com](http://www.ijraset.com)**

**Call:  08813907089**

**E-mail ID: [ijraset@gmail.com](mailto:ijraset@gmail.com)**

# Matlab Simulation on Adaptive Voltage Control Strategy of Three Phase Inverter for Stand alone Distributed Generation System

Piyush Kumar Singh<sup>1</sup>, Mr. Kaushal Sen<sup>2</sup>, Mrs. Vasundhara Shukla<sup>3</sup>

<sup>1</sup>Research Scholar, <sup>2,3</sup>Assistant Professor, Department of Electrical and Electronics Engineering Oriental College of Technology, Bhopal (MP), India

**Abstract:** This document proposes a robust and adaptable voltage control of the three-phase voltage inverter. First, the status model of the load side of the inverter is established, which takes into account the uncertainties of the system parameters. The proposed adaptive voltage control technique combines an adaptive control and a state feedback control term. The former compensates for the uncertainties of the system, while the second forces the dynamics of the error to converge to zero. Furthermore, the proposed algorithm is easy to implement, but is very robust, due to the uncertainties of the system and sudden load disturbances. In this document, the analysis is also performed to show the robustness of the closed loop control system. Undefined load and non-linear load. The simulation and experimental results are presented under the assumption of the corresponding non-adaptive voltage regulator.

**Keyword:** Adaptive control, distributed generation (DG) system (DGS), load current observer, stand-alone, three-phase inverter, voltage control.

## I. INTRODUCTION

In recent years, environmentally friendly distributed generation systems (DGS), such as wind turbines, solar cells and fuel cells, are growing dramatically because they can meet the growing demand for electricity due to the rapid growth of electricity economy and the rigid environmental regulations relating to greenhouse gas emissions. In general, the DGS are interconnected in parallel with the electricity grid and provide the maximum electrical power to the grid. However, there are some areas (ex..remote islands or villages) where the connection to the network is expensive or impractical and, therefore, small-scale autonomous DGS are the only efficient and cost-effective options. In this DGS, depending on consumer energy demand, there are situations in which some DGS operate in parallel or independently. In any case, a stable operation of each DGS unit is as important as the stability of the DGS operating in parallel, where the correct load distribution of each unit is one of the main research problems, since the voltage regulator is used commonly in a DGS unit.

## II. DESCRIPTION OF THE SYSTEM AND MATHEMATICAL MODEL

The configuration of a typical DGS in an independent operation is shown in Fig. 1. Consists of renewable energy sources (eg Wind turbines, solar cells and fuel cells), an AC to DC power converter (wind turbines) or unidirectional converter of the dc-dc elevator (solar cells or fuel cells), a three-phase DC-AC inverter, an LC output filter, a DSP control unit and a local load. As shown in Figure 1, a transformer can be used to provide electrical isolation or increase the output voltage of the three-phase current.

Investor, but it can result in higher costs and greater volume. In addition, storage systems such as batteries, ultracapacitors and flywheels can be used to generate electricity during transitory (ex. startup or sudden change of load) and improve the reliability of renewable energy sources.

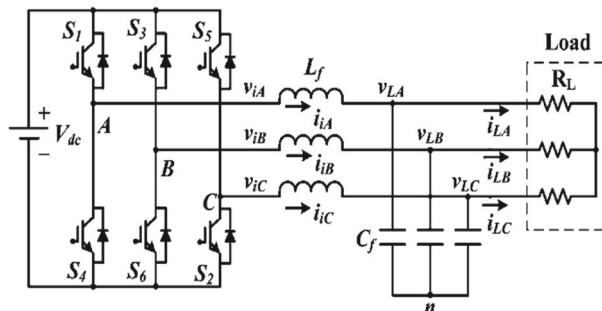

Fig. 1. Circuit diagram of a three-phase inverter with an LC output filter for isolated DGSs.

In this paper, we discuss the design of the three-phase inverter voltage regulator for stand-alone DGS that provides excellent voltage regulation (for example, fast transient response, small steady state error and low THD) in case of sudden load variations, unbalanced load and non-linear load. Therefore, renewable energy sources and AC to DC power converters or unidirectional DC-DC converters can be replaced by a DC voltage source (VCC). Figure 1 shows the circuit model of a three-phase inverter with an LC output filter for stand-alone DGS. As shown in Fig. 1, the system consists of four parts: a DC voltage source (VDC), a three-phase pulse width modulated inverter (PWM) (S1 to S6), an output filter (Lf) and (Cf) and three-phase load (RL). Note that the LC filter is necessary to suppress the high-order harmonic components of the inverter output voltage due to the PWM action and, therefore, to supply the load with sinusoidal voltages. The circuit model in Fig. 1 uses the following quantities. The output lines of the phase and neutral converters are supplied by  $V_i = [v_{iA} \ v_{iB} \ v_{iC}]^T$  and  $I_i = [i_{iA} \ i_{iB} \ i_{iC}]^T$ , respectively. Furthermore, the neutral voltage and the load lines of the phase current are represented by the  $V_L =$  vectors  $[v_{LA} \ v_{LB} \ v_{LC}]^T$  and  $I_L = [i_{LA} \ i_{LB} \ i_{LC}]^T$ , respectively.

Suppose that the three-phase voltages and voltages used in Fig. 1 are balanced. By applying the Kirchoff's current law and the Kirchoff's voltage law in the LC output filter, the following voltage and current equations can be obtained: Under the conditions, the state equations (1) mentioned above in the stationary abc reference frame can be transformed into equations in the stationary  $\alpha\beta$  reference frame using the following expression [2], [3]X (2)

$$\text{where } X_{\alpha\beta} = x_{\alpha} + jx_{\beta}.$$

Therefore, the equations of state (1) can be transformed into:

$$\text{where } V_{L\alpha\beta} = [v_{L\alpha} \ v_{L\beta}]^T, I_{L\alpha\beta} = [i_{L\alpha} \ i_{L\beta}]^T, V_{i\alpha\beta} = [v_{i\alpha} \ v_{i\beta}]^T \text{ and } I_{i\alpha\beta} = [i_{i\alpha} \ i_{i\beta}]^T.$$

Subsequently, the state equations in the stationary reference frame  $\alpha\beta$  can be transformed into the equations in the reference frame dq in the synchronous rotation of the following formula:

$$X_{dq} = x_d + jx_q = X_{\alpha\beta}e^{-j\theta} \quad (4)$$

where  $\theta$  is the transformation angle,  $\omega$  is the angular frequency ( $\omega = 2\pi f$ ), and  $f$  is the fundamental frequency of voltage or current.

Finally, (3) can be transformed into (5)

$$\text{where } V_{Ldq} = [v_{Ld} \ v_{Lq}]^T, I_{Ldq} = [i_{Ld} \ i_{Lq}]^T \text{ and } I_{idq} = [i_{id} \ i_{iq}]^T.$$

Furthermore, (5) can be rewritten as follows:  $i_{Lq}^T, V_{idq} = (6)$

where, and  $i_{iq}$  indicate the temporal derivatives of  $v_{Ld}, v_{Lq}, i_{id}$  and  $i_{iq}$ , respectively

Note that  $V_{Ldq}$  and  $I_{idq}$  are the state variables,  $V_{idq}$  is the control input and  $I_{Ldq}$  is defined as a disturbance.

In this document, the following assumptions are made to design an adaptive controller and an observer of the current load.

- 1)  $v_{Ld}, v_{Lq}, i_{id}$  and  $i_{iq}$  are available.
- 2) The desired voltages of the load axis  $v_{Ldref}$  and  $v_{Lqref}$  are constant and their derivatives can be zeroed
- 3)  $i_{Ld}$  and  $i_{Lq}$  are unknown and change very slowly during the sampling period [15].

Single-phase voltage source converter

The single-phase voltage converter can be found as a full-bridge topology. Although the range of energy they cover is low, they are widely used in power supplies, in single-phase UPSs, and currently form high-powered static topologies, such as the revised multi-cell configurations.

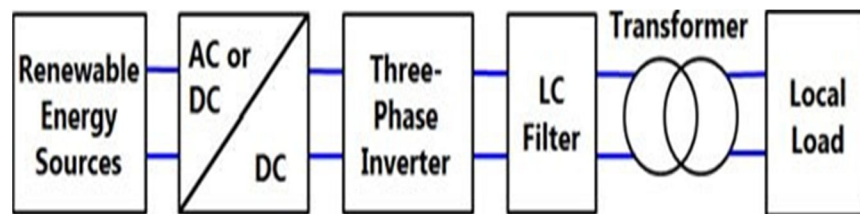

Fig.2. Block diagram of individual DGS using renewable energy sources.

### III. PERFORMANCE EVALUATION

In this section simulations and experiments are performed and different results are presented. To evaluate the performance of the adaptive control system based on the proposed observer, two types of power levels are studied (200 kVA class and 450 VA class) because the 200kVA unit is a too high power level for laboratory. In this document, simulations are performed using Matlab/Simulink software and experiments are implemented in DGS

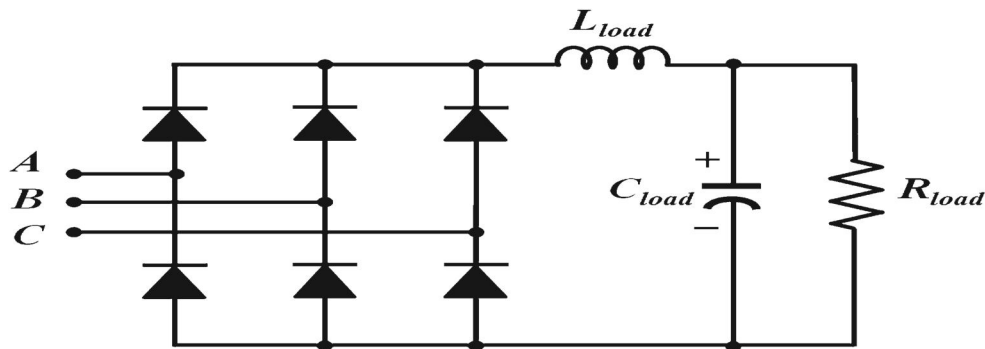

Fig. 3: Nonlinear load circuit with a three-phase diode rectifier.

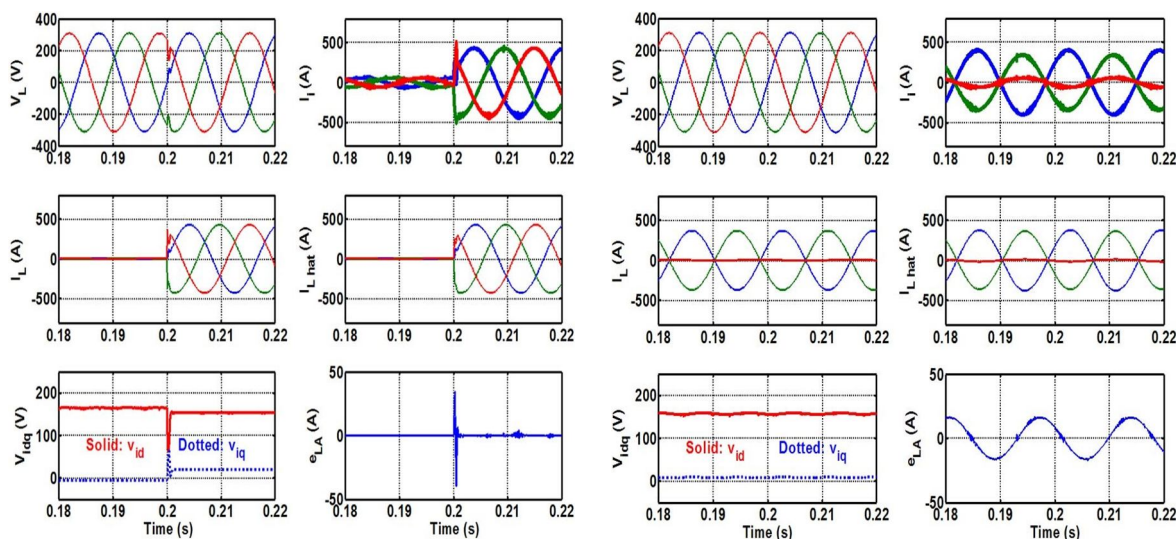

Figure 4; Matlab Simulation result analysis

TABLE 1 SYSTEM PARAMETERS OF 200 kVA UNIT

DGS rated power	200 kVA
dc-link voltage ( $V_{dc}$ )	600 V
Switching & sampling frequency	4 kHz
Load output voltages ( $V_{L, rms}$ )	220 V
Fundamental frequency ( $f$ )	60 Hz
Output filter capacitance ( $C_f$ )	500 $\mu$ F
Output filter inductance ( $L_f$ )	0.3 mH

The currents ( $i_i$ ) and the charge output voltages ( $v_L$ ) are measured with the sensors and then transformed into  $i_{dq}$  and  $v_{Ldq}$  quantities in the reference frame dq of synchronous rotation, respectively. On the other hand, load currents ( $i_{Ldq}$ ) can be estimated using the current proposed observer. In this document, a PWM spatial vector technique is used to approximate the reference voltages and provide less harmonic stress to the load. Simulations and experiments are performed to demonstrate the transient and stationary performance of the control algorithm proposed in the following four different cases:

- 1) Case 1) balanced resistive load (transient behaviour: from 0% to 100%);
- 2) Case 2) balanced resistive load (transient behaviour: from 100% to 0%);
- 3) Case 3) unbalanced resistive load (open phase C); Case 4) non-linear load (a three-phase diode rectifier).

Fig. 5. Simulation results of the proposed control scheme under Case 1 for a 200-kVA unit (balanced resistive load: 0%–100%).

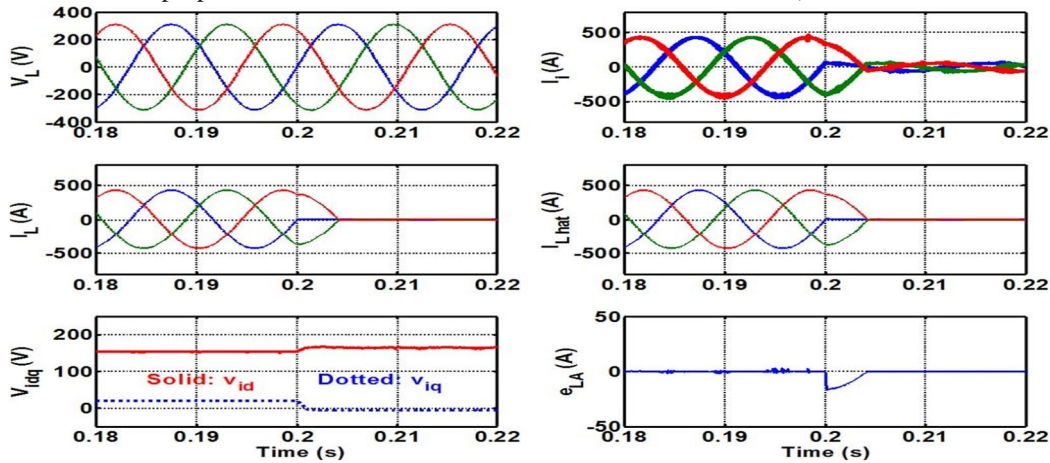

Fig. 5: Simulation results of the proposed control scheme under Case 2 for a 200-kVA unit (balanced resistive load: 100% to 0%).

$$\delta_d = \delta_q = 1000, \text{ and}$$

$$M^T = 10^4 \times \begin{bmatrix} -0.3162 & -0.0039 & 3.0955 & -0.0000 \\ 0.0039 & -0.3162 & -0.0000 & 3.0955 \end{bmatrix} .$$

Note that these parameters are chosen through extensive simulation studies with the procedures mentioned in notes 1 and 4. The figures show the results of the simulation of the control technique proposed in cases for a unit of 200 kVA, respectively. Each figure shows the waveforms of the load voltages (VL), the inverter currents (Ii), the load currents (IL), the estimated load currents (IL), the control inputs (vid and viq.) and the current load error (eLA = iLA - iLhat). In figs. a resistance of 0.726-Ω is used for a balanced resistive load and an unbalanced resistive load. Furthermore, to obtain the non-linear load waveforms in Fig. 10, the following values are selected: L load = 0.3mh, 'C'load = 4000μF and R load = 1.2 Ω. Figures 7 and 8 show the performance of the transient under a balanced resistive load and the load voltage waveforms are only slightly distorted during transients and return to steady state within 0.52ms.

Fig. 6; Simulation results of the proposed control scheme under Case 3 for a 200-kVA unit (unbalanced resistive load: phase C opened).

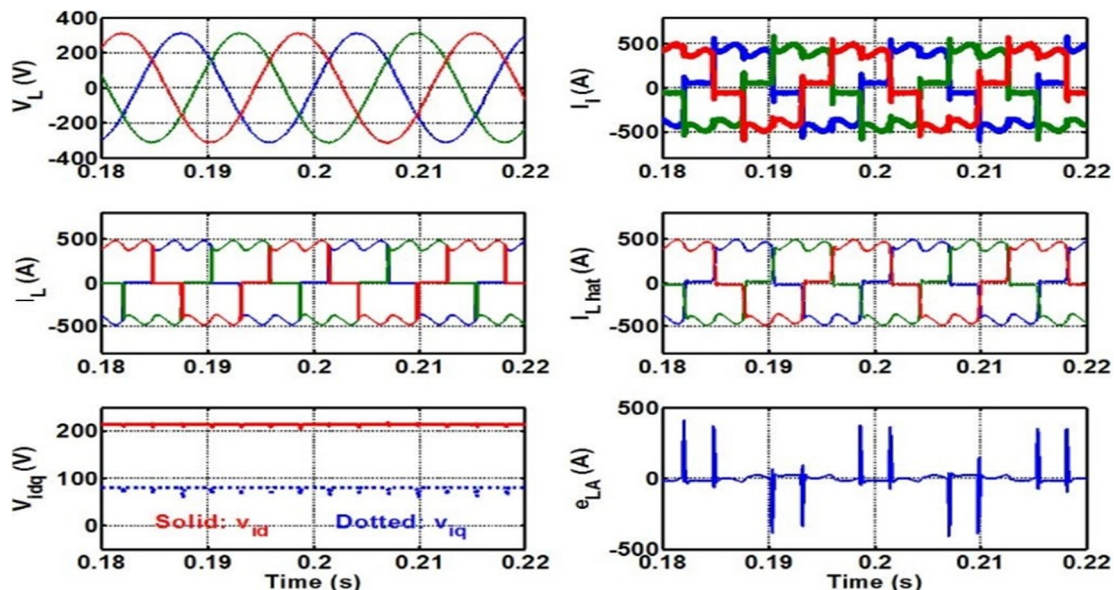

TABLE II  
Steady-State Performance Of Simulation Results For A 200-Kva Unit With Proposed Control Scheme

Load Types	Load Output Voltages ( $V_{rms}$ )			THD (%)
	$v_{LA}$	$v_{LB}$	$v_{LC}$	
Balanced resistive load	219.88	219.86	219.85	0.211
Unbalanced A&B resistive load	220.17	219.94	219.65	0.208
No load	219.89	219.84	219.86	0.224
Nonlinear load (Crest factor 1.37:1)	219.57	219.45	219.32	0.781

#### IV. CONCLUSION

This document presents a solid strategy for adaptive voltage control of a three-phase inverter for an independent DG unit. The proposed controller is not only easy to implement, but also robust due to system uncertainties and sudden load disturbances. Furthermore, the stability of the proposed closed-loop control system has been demonstrated mathematically. To support the validity of the proposed control algorithm, simulations and experiments were performed using a Simulink software and a DGS prototype test bench with a TMS320F28335DSP, respectively. Finally, the simulation and experimental results have shown that the proposed control scheme offers satisfactory voltage regulation performance, such as fast dynamic behaviour, a small steady state error and a low THD under different loads (ex. without load, balanced load, unbalanced load and non-linear load) In the presence of uncertainties in the system parameters.

#### REFERENCE

- [1] H. K. Kang, C. H. Yoo, I. Y. Chung, D. J. Won, and S. I. Moon, "Intelligent coordination method of multiple distributed resources for harmonic current compensation in a microgrid," J. Elect. Eng. Technol., vol. 7, no. 6, pp. 834–844, Nov. 2012.
- [2] M. Liserre, T. Sauter, and J. Y. Hung, "Future energy systems: Integrating renewable energy sources into the smart power grid through industrial electronics," IEEE Ind. Electron. Mag., vol. 4, no. 1, pp. 18–37, Mar. 2010.
- [3] S. Bogosyan, "Recent advances in renewable energy employment," IEEE Ind. Electron. Mag., vol. 3, no. 3, pp. 54–55, Sep. 2009.
- [4] B. C. Sung, S. H. Lee, J. W. Park, and A. P. S. Meliopoulos, "Adaptive protection algorithm for overcurrent relay in distribution system with DG," J. Elect. Eng. Technol., vol. 8, no. 5, pp. 1002–1011, Sep. 2013.
- [5] M. Y. Kim, Y. U. Song, and K. H. Kim, "The advanced voltage regulation method for ULTC in distribution systems with DG," J. Elect. Eng. Technol., vol. 8, no. 4, pp. 737–743, Jul. 2013.
- [6] L. Gertmar, L. Liljestrand, and H. Lendenmann, "Wind energy powerthat-be successor generation in globalization," IEEE Trans. Energy Convers., vol. 22, no. 1, pp. 13–18, Mar. 2007.
- [7] A. Q. Huang, M. L. Crow, G. T. Heydt, J. P. Zheng, and S. J. Dale, "The future renewable electric energy delivery and management (FREEDM) system: The energy internet," Proc. IEEE, vol. 99, no. 1, pp. 133–148, Jan. 2011.
- [8] A. Mokhtarpour, H. A. Shayanfar, M. Bathaee, and M. R. Banaei, "Control of a single phase unified power quality conditioner-distributed generation based input output feedback linearization," J. Elect. Eng. Technol., vol. 8, no. 6, pp. 1352–1364, Nov. 2013.
- [9] M. N. Marwali, J. W. Jung, and A. Keyhani, "Stability analysis of load sharing control for distributed generation systems," IEEE Trans. Energy Convers., vol. 22, no. 3, pp. 737–745, Sep. 2007.
- [10] Y. Zhang, M. Yu, F. Liu, and Y. Kang, "Instantaneous current-sharing control strategy for parallel operation of UPS modules using virtual impedance," IEEE Trans. Power Electron., vol. 28, no. 1, pp. 432–440, Jan. 2013.
- [11] J. He and Y. W. Li, "An enhanced microgrid load demand sharing strategy," IEEE Trans. Power Electron., vol. 27, no. 9, pp. 3984–3995, Sep. 2012.
- [12] G. K. Kasal and B. Singh, "Voltage and frequency controllers for an asynchronous generator-based isolated wind energy conversion system," IEEE Trans. Energy Convers., vol. 26, no. 2, pp. 402–416, Jun. 2011.
- [13] I. Vechiu, O. Curea, and H. Camblong, "Transient operation of a four-leg inverter for autonomous applications with unbalanced load," IEEE Trans. Power Electron., vol. 25, no. 2, pp. 399–407, Feb. 2010.
- [14] H. Nian and R. Zeng, "Improved control strategy for stand-alone distributed generation system under unbalanced and non-linear loads," IET Renew. Power Gener., vol. 5, no. 5, pp. 323–331, Sep. 2011.



10.22214/IJRASET



45.98



IMPACT FACTOR:  
7.129



IMPACT FACTOR:  
7.429



# INTERNATIONAL JOURNAL FOR RESEARCH

IN APPLIED SCIENCE & ENGINEERING TECHNOLOGY

Call : 08813907089  (24\*7 Support on Whatsapp)