



iJRASET

International Journal For Research in
Applied Science and Engineering Technology



INTERNATIONAL JOURNAL FOR RESEARCH

IN APPLIED SCIENCE & ENGINEERING TECHNOLOGY

Volume: 7 Issue: III Month of publication: March 2019

DOI: <http://doi.org/10.22214/ijraset.2019.3315>

www.ijraset.com

Call:  08813907089

E-mail ID: ijraset@gmail.com

A Review of Cycloconverter Type Voltage and Frequency Variations for High Frequency Applications

D. Velmurugan¹, V. Janardhan², S. Karthik³, A. Naveen Kumar⁴

¹ Assistant Professor/EEE, Info Institute of engineering, Coimbatore, Tamilnadu, India

^{2,3,4} UG Student/EEE, Info Institute of engineering, Coimbatore, Tamilnadu, India

Abstract: This paper presents a technique to control the speed of single phase induction motor by using Thyristor. Induction motor is a constant speed machine when operated from the mains. However it is necessary to vary the speed of the motor in some applications. The speed of a motor basically depends on the supply frequency and supply voltage. This paper examines the use of cycloconverters to vary the speed of single phase induction motors. Cycloconverters work on changing the supply frequency to vary the speed of the motor. With the aid of three push buttons connected to the microcontroller and the program written on it, the speed of the motor was varied in three steps, at F , $F/2$ & $F/3$. This method is suitable for such application where the load varies approximately as square of speed, such as centrifugal pumps drives, fan load, refrigerator, blower etc

Index Terms: Induction Motor, Speed control, Cycloconverter, Microcontroller, Variable frequency drives.

I. INTRODUCTION

Speed control of Induction motor plays important role in industries, there are various ways to control speed of motor but considering its efficiency, we proposed the designed to control the speed of a single phase induction motor in three steps by using cycloconverter technique by thyristors. A.C. motors have the great advantages of being relatively inexpensive and very reliable. Induction motors in particular are very robust and therefore used in many domestic appliances. The induction motor is known as a constant-speed machine, the difficulty of varying its speed by a cost-effective device is one of its main disadvantages. Cycloconverter is one of the methods of controlling the speed, cycloconverter frequency can be varied by conduction period for each MOSFET.

II. PROJECT DESCRIPTION

The Cycloconverter have several important features, cycloconverter frequency can be varied by conduction period for each MOSFET. However, control of induction motor is challenging task, many authors have suggested different techniques for speed control of induction of induction motor. For speed-sensorless operation, as both the initial rotational direction and speed is unknown, it would be difficult to achieve smooth and fast resumption of normal operation if the starting scheme is not deliberately designed. In this paper, a method based on variable frequency control (V/F) is proposed to address this problem. The variable frequency has important usage in the industrial world. The electricity produced from the generating station are normally 50Hz and these frequency is not applicable for most of the application

III. PROPOSED SYSTEM

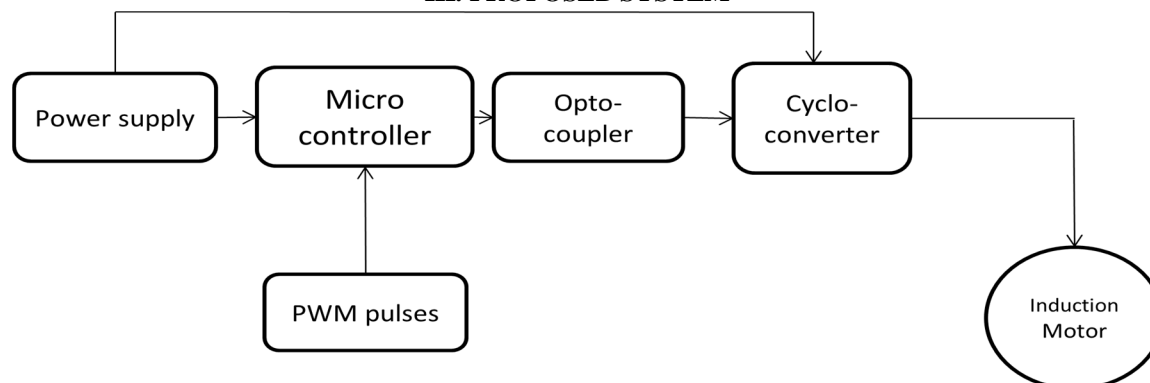

Fig. 1 Proposed block diagram

The complete circuit of the cycloconverter is shown in figure 1. This design proposes the open loop control topologies of a induction motor using cyclonverter. The system is powered by 230VAC 50Hz supply that is rectified to 12V DC and then regulated to 5V DC. The cycloconverter has two bridges, bridge 1 (positive cycle) and bridge 2 (negative cycle). The motor is connected between the bridges. Each bridge is made up of four thyristors. Each thyristor is connected through an optoisolator to the microcontroller. The microcontroller contains the program codes that control the operation of the cycloconverter.

IV. SIMULATION OF CONVERTOR TOPOLOGIES

A. Single Phase Cycloconverter Converter With R Load

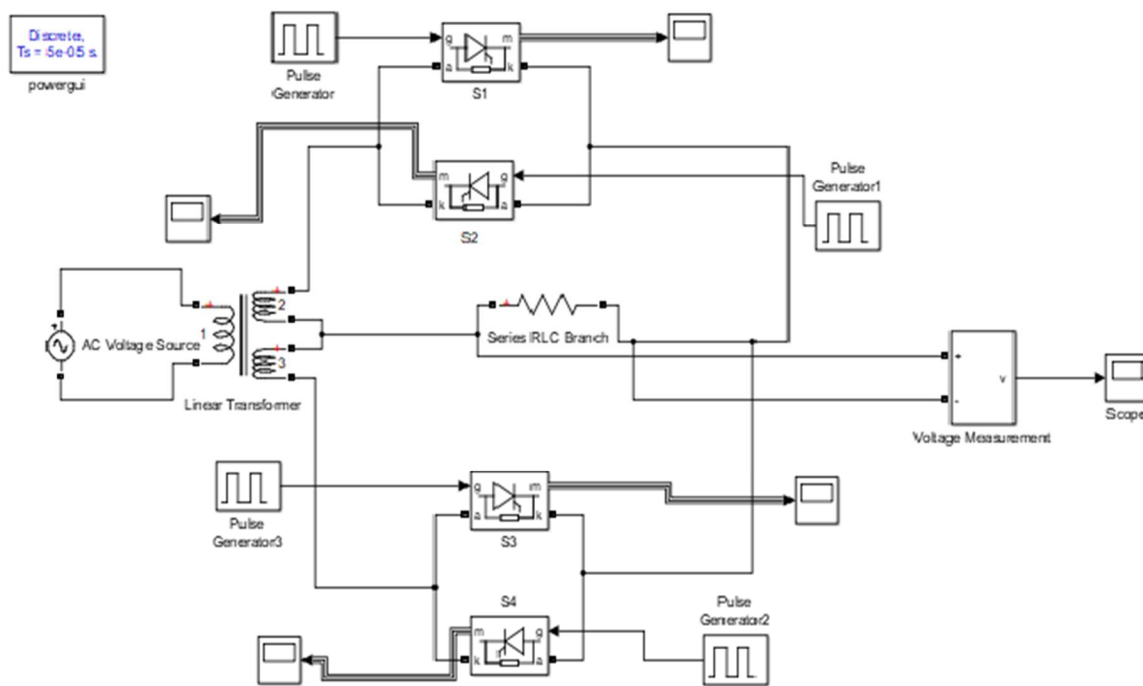

Fig 1: Simulation Circuit For CYCLO-Converter With R Load

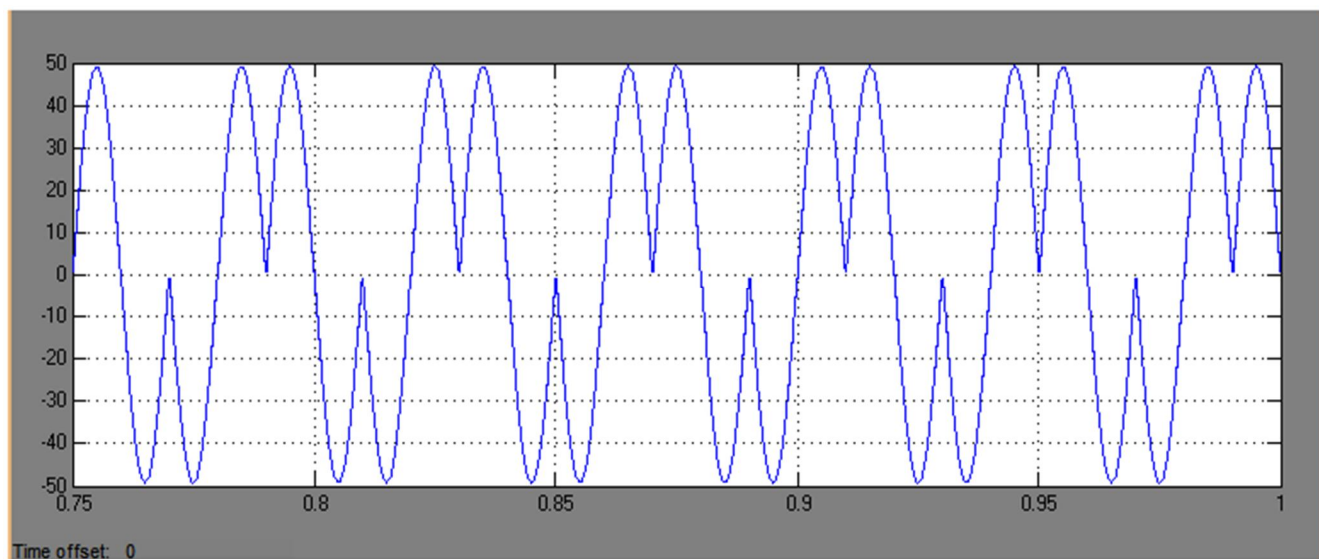

Fig 1a: Simulaton Output Voltage With R Load

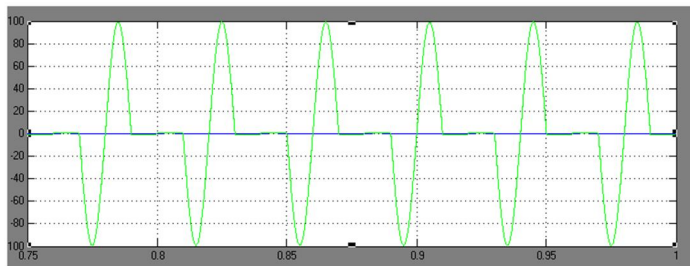

Fig 1b: Output Of Pulse Generator(1,2)

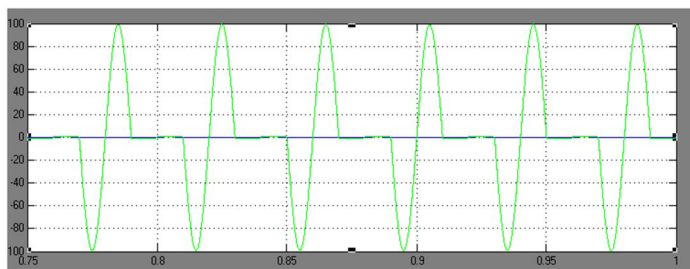
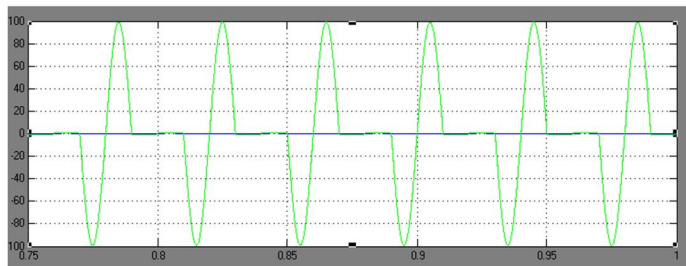
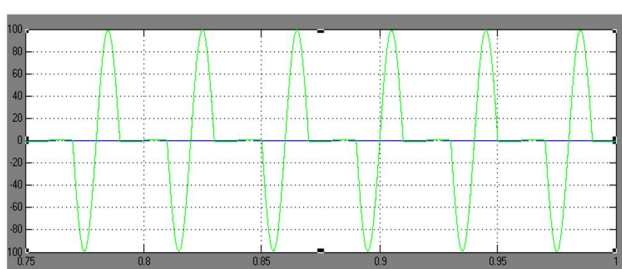

Fig 1c: Output Of Pulse Generator(3,4)



The fig 1, illustrates the simulation of single phase cycloconverter. The cycloconverter is fed with R load respective to the AC supply. Pulse generator is fed to each of the thyristor unit shown in fig 1b, 1c respectively

B. Single Phase Frequency Control Of Cycloconverter

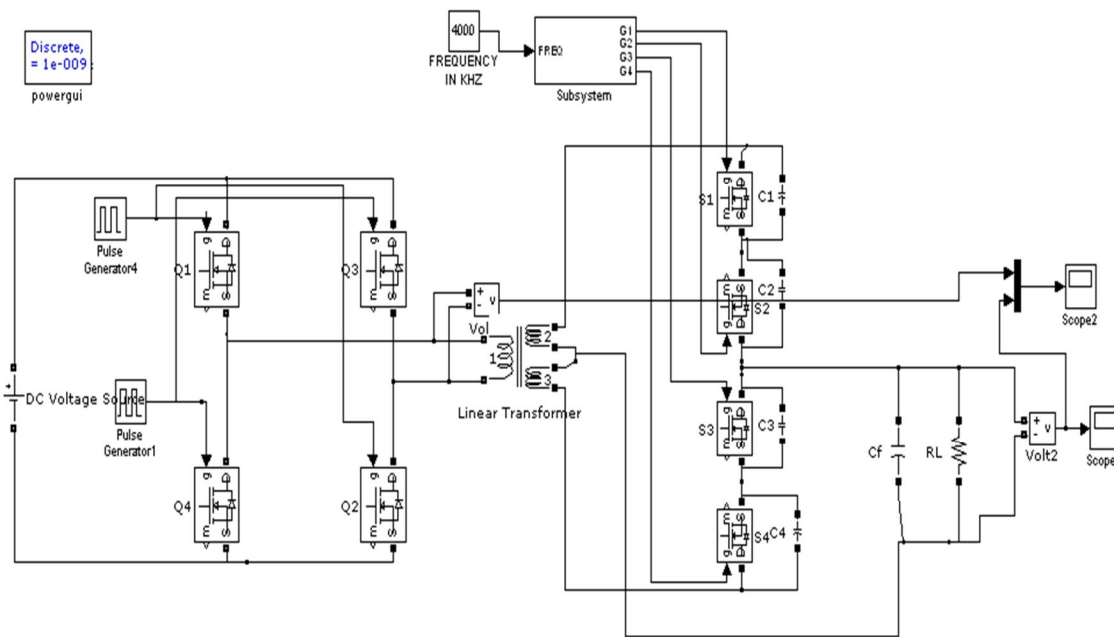

Fig 2: Simulation Circuit For Frequency Control Cyclo-Converter For 10khz

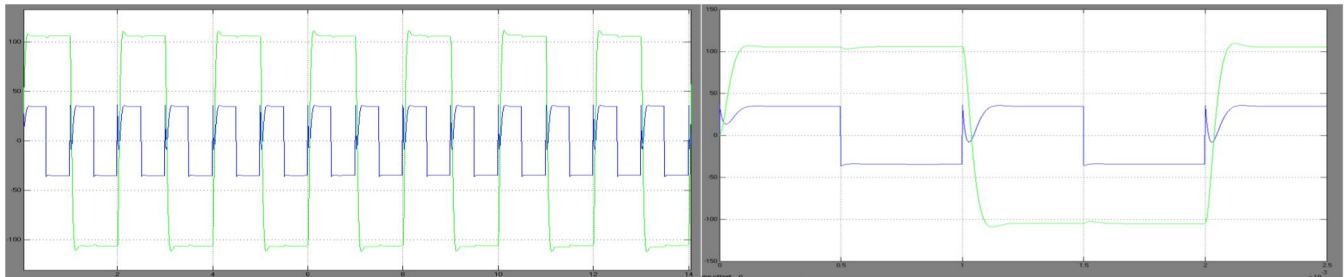

Fig 2a: Output Of 10khz To 20khz

Fig 2b: Output Of 10khz To 5khz

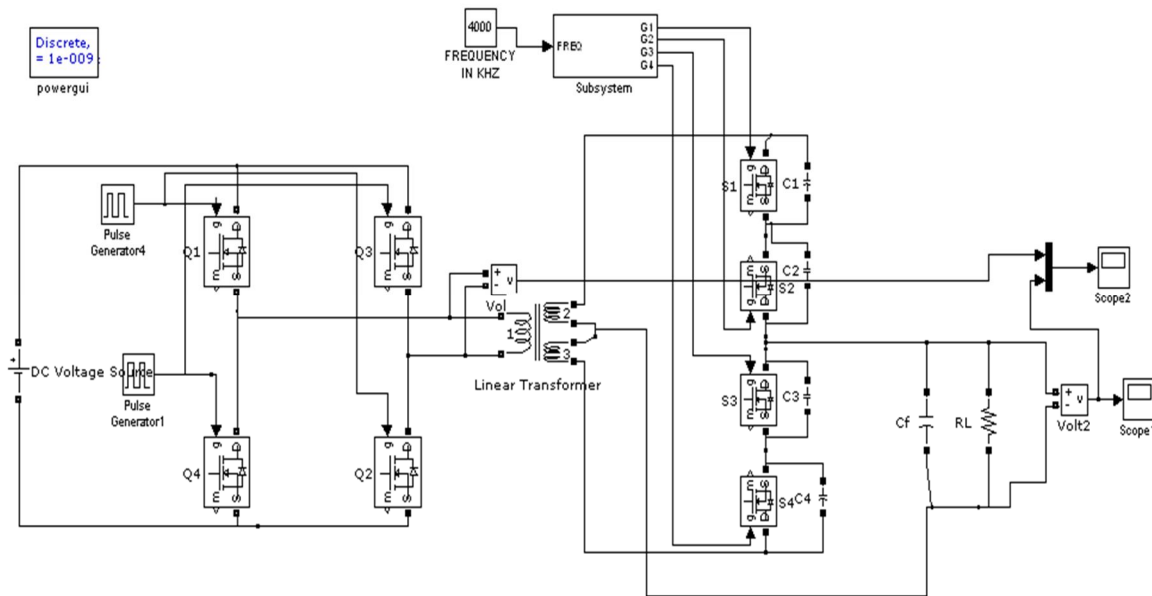

Fig 3: Simulation Circuit For Frequency Control Of Cyclo-Converter For 1khz

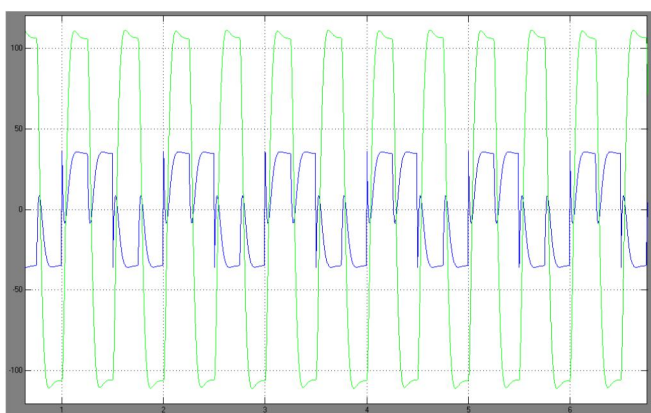

Fig 3a: Output Of 1khz To 4khz

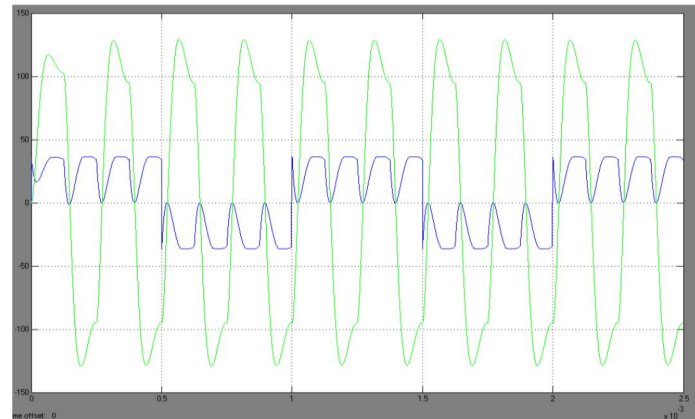

Fig 3b: Output Of 1khz To 2khz

The fig 2, illustrates the simulation of single phase cycloconverter for variable frequency drives. As the frequency is varied according to $F, F/2, F/3$ the speed changes which is directly proportion to the supply voltage. The output waveforms are obtained in fig 2a,2b,3a,3b.

C. Single Phase Step Up Cycloconverter Converter With R Load

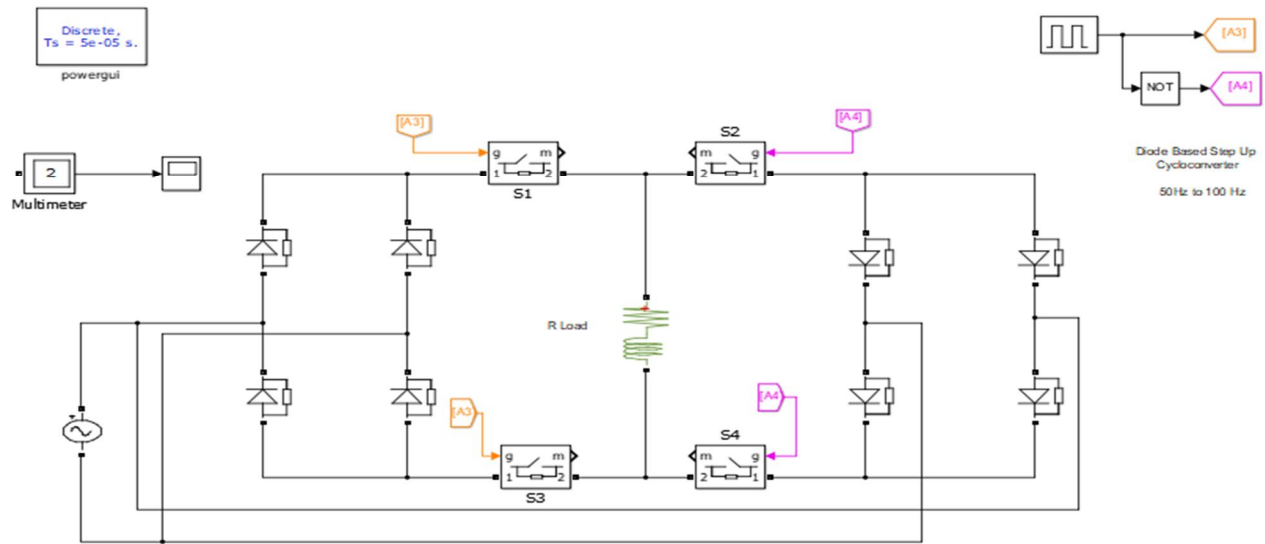

Fig 4: Simulation Circuit Of Step Up Cyclo-Converter With R Load

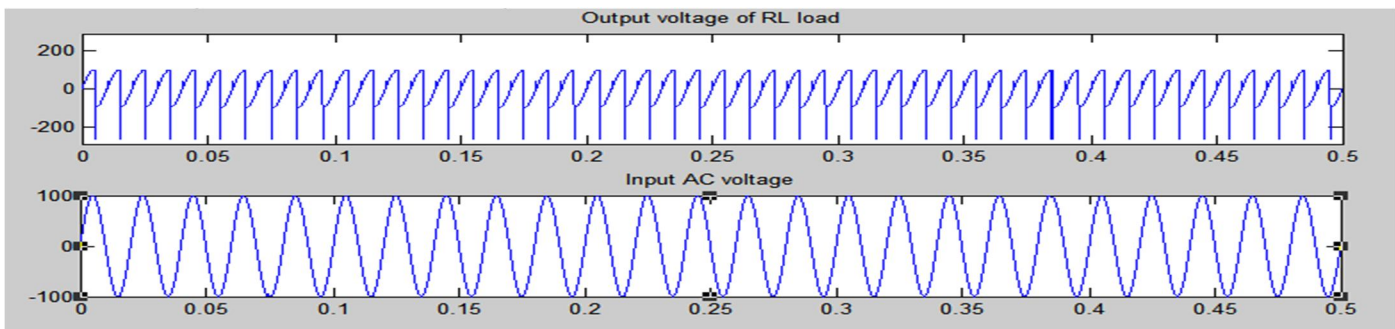

Fig 4a: Output Of Step Up Cycloconverter For R Load

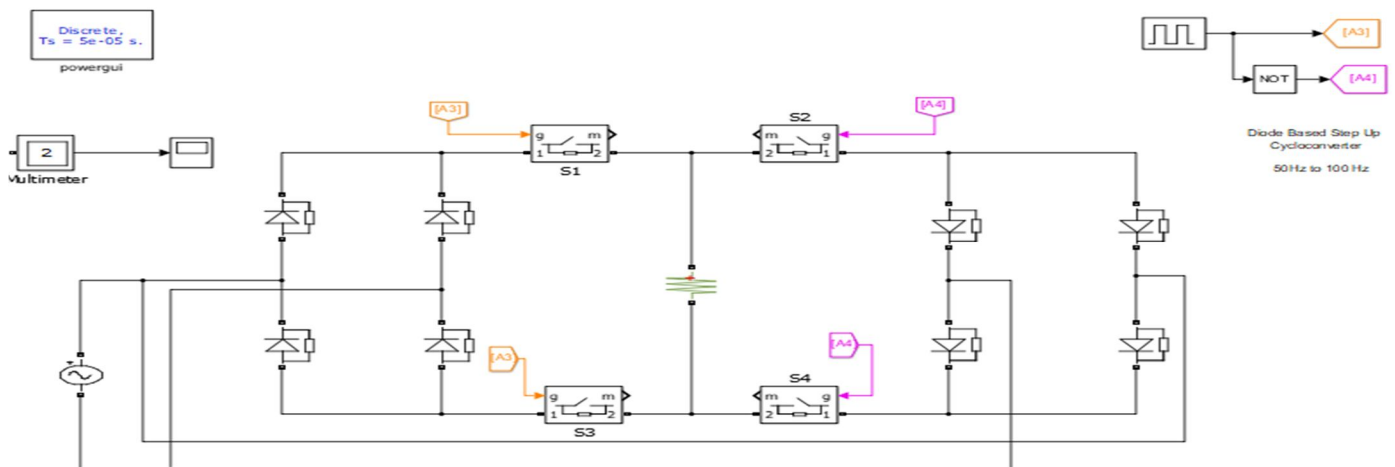

Fig 5: Simulation Circuit Of Step Up Cyclo-Converter With RL Load

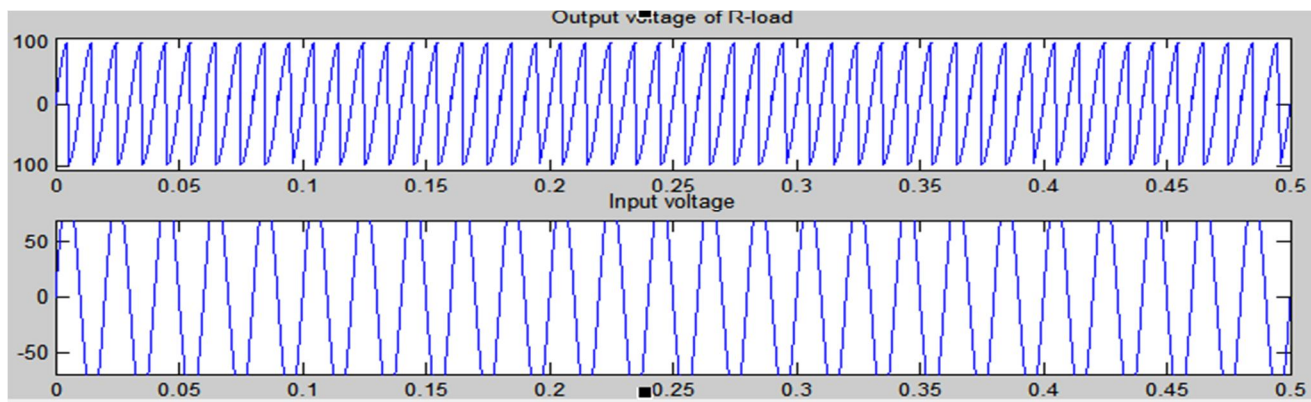

Fig 5b: Output Of Step Up Cycloconverter For RL Load

The simulation result is obtained by using MATLAB. A whole simulation will be kept under a discrete mode to occur an instant output in a discrete manner. An input voltage and current ($V_{IN}=100V$) is connected with the series R load and RL load with MOSFET. Gate pulse is given to the MOSFET from the pulse generator. Finally the input and output voltage ($V_{in}=100V$) is connected to the scope in the circuit.

V. CONCLUSION

In this work, the model of Cycloconverter operation using MATLAB/Simulink software has been carried out. Simulation result is feasible to realize the designed cycloconverter in various basic AC-AC converter as a step-up frequency changer. In this work the total harmonic distortion is reduced as 0.15% by changing the softswitches in cycloconverter design. The cyclo-converter circuit has designed for variable frequency drives, the main aim of this paper is to attain variable speed for various applications and also for induction motor for adjustable frequency. Single phase Cyclo-converter used to change the speed of induction motor with the help of microcontroller, different desired frequency is obtained to equalize the desired speed. This different frequency of cyclo-converter is obtained in the manner of adjustable speed to F , $F/2$ & $F/3$. Furthermore, it provides means for limiting the slip and consequently the motor current, also high voltage circuit from affecting the system receiving the signal can be prevent with the help of opto-coupler. This means a reduction in the Cyclo-converter rating and better efficiency.

REFERENCES

- [1] Puja Talukder, Prashant Kumar Soori, Benetta Aranjio "Speed Control of Induction Motor Drive Using Universal Controller" International Power Engineering and Optimization Conference (IEEE) 2012
- [2] Vinamra Kumar Govil, Yogesh Chaurasia "Modeling & Simulation of PWM Controlled Cycloconverter FED Split Phase Induction Motor" International Journal of Advanced Research in Electrical, Electronics and Instrumentation Engineering Vol. 1, 2012
- [3] Munira Batool, Aftab Ahmad "Mathematical Modeling And Speed Torque Analysis Of Three Phase Squirrel Cage Induction Motor Using Matlab Simulink For Electrical Machines Laboratory" International Electrical Engineering Journal (IEEJ) Vol. 4 2013
- [4] K.S.pandya, N. B. Danidhariya "Simulation of Step-down Cycloconverter For Speed Control of Single Phase Induction Motor" International Journal of Advance Engineering and Research Development (IAERD) Vol. 1, 2014
- [5] J. Suganthi vinodhini , R. Samuel Rajesh Babu "Single Phase to Single Phase Step-Down Cycloconverter for Electric Traction Applications" American-Eurasian Journal of Scientific Research 2016
- [6] Karnika Sharma, Barun Gupta, Isaan Gupta, Neha Gupta "Speed Control of Single Phase Induction Motor Using TRIAC & Reversal of Direction" Journal of Emerging Technologies and Innovative Research (JETIR) Vol.3,2016
- [7] Richa Gajbhiye, Rupali Malghati, Rupali Wadandre, Shalini Meshram, Shivani Wanker "Speed Control of Induction Motor Using Single Phase Cycloconverter" International Journal of Advanced Research in Education & Technology (IJARET) Vol. 4 2017
- [8] Ayebatonye Marttyns Epemu, Kingsley Okeoghene Enalume "Speed Control of a Single Phase Induction Motor Using Step-down Cycloconverter" International Journal of Industrial and Manufacturing Systems Engineering (IJIMSE) 2018



10.22214/IJRASET



45.98



IMPACT FACTOR:
7.129



IMPACT FACTOR:
7.429



INTERNATIONAL JOURNAL FOR RESEARCH

IN APPLIED SCIENCE & ENGINEERING TECHNOLOGY

Call : 08813907089  (24*7 Support on Whatsapp)