



iJRASET

International Journal For Research in
Applied Science and Engineering Technology



INTERNATIONAL JOURNAL FOR RESEARCH

IN APPLIED SCIENCE & ENGINEERING TECHNOLOGY

Volume: 7 Issue: III Month of publication: March 2019

DOI: <http://doi.org/10.22214/ijraset.2019.3043>

www.ijraset.com

Call:  08813907089

E-mail ID: ijraset@gmail.com

Early Warning Model for Aqua Organism Detection in Hydro Power Stations using IOT

Dinesh Kumar V¹, Vigneshwaran R², Youvaraj J³, Mr. S. Sundararajan⁴

^{1, 2, 3}UG Student, Department of ECE, Sri Muthukumaran Institute of Technology, Chennai, India

⁴Assistant professor, Department of ECE, Sri Muthukumaran Institute of Technology, Chennai, India

Abstract: It is known that the evolution of technologies is greatly increasing in the modern day. The utilization of technologies in various sectors is very low. It is known that the renewable resources are utilized in various places for generating electricity. Renewable resources are used in various forms like Solar energy, wind energy etc. The major source for electricity is generated using Hydro power generator. The use of this hydro power generation is performed using water resource. During this, a mechanism is executed to extract power from the water resources. But due to the presence of aquatic life in dams, the creatures reduce the energy generation. In some cases, they damage the energy generating mechanism which gradually reduces the energy generation as well as requires manual work to repair the mechanism. So we propose this system which increases the energy generation and provides indication.

Keywords: component, formatting, style, styling, insert (key words)

I. INTRODUCTION

As we all know that the energy production using non-renewable resources are going to be exhausted. And also the method of producing energy from these resources has been affecting the environment and the society in numerous ways. So we started searching for the resources that are available plenty in the environment and also at the same time we see to that the methods of producing energy from these does not affect the environment and also it should not pollute it.

And we sorted out ways to produce energy from different sources like producing solar energy from sun, wind energy from the wind and the tidal energy with the use of water.

Here we are going to see about how the energy are produced with the water in the dams and some problems that produce during the production of energy. In some cases in this method of producing energy we may lose many aqua organisms and at the same time it affect the production of energy. So we are going use an microcontroller (raspberry pi) o monitor the entry of aqua organisms within the range of turbine and also at the same it gives us alert message and stop the turbine if the aqua organisms had breached within the area.

II. EXISTING SYSTEM

The existing systems include only the manual power to stop the entry of aqua organisms. They use a fish net to catch the aqua organisms that try to enter into the turbine range.

If suppose if the fish net has been torned then the aqua organisms will flow freely to turbine and got struck and get died. This happens until the human notices it so until the production of energy will be less and life of aqua organisms will be lost. And then after noticing it they will change with a new fish net to protect the fishes from the turbine.

III. PROPOSED SYSTEM

This proposed systems overcomes the drawback of existing system, this system has net fault detector in this system a fish net is used to restrict the flow of aqua organisms.

If there is any fault is detected in the net it will be notified by the detector. Microwave radar is also detect the aqua organisms which comes into its range and will send the data to the raspberry pi.

A speed sensor is used to detect the speed of the water flowing through the energy generation mechanism. If any abnormality is obtained, then the flow of water is restricted using a solenoid valve and hydro-generator door is closed. The water pump motor is used to pump out the water from the stored medium.

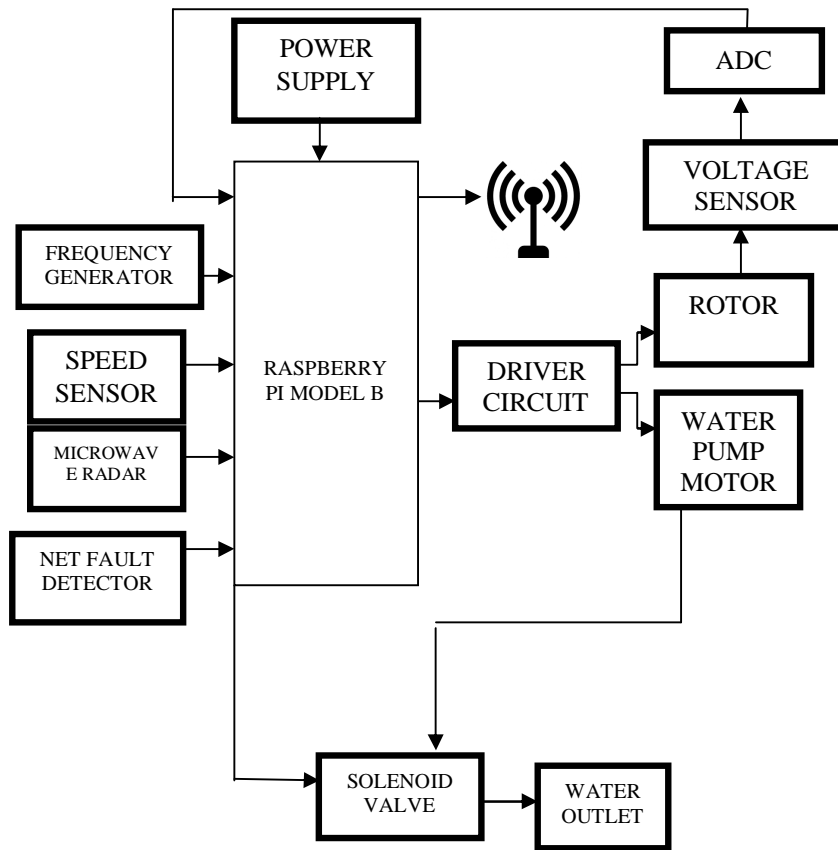

A. Transmitter Section

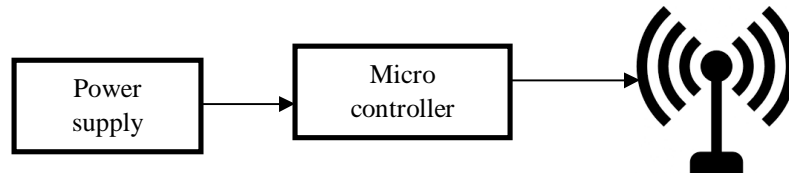

The transmitting section works out with the micro controller and gets the information of voltage produced using the voltage sensor and feeds the information into the server using iot module and it can be accessed from anywhere of the world.

B. Receiving Section

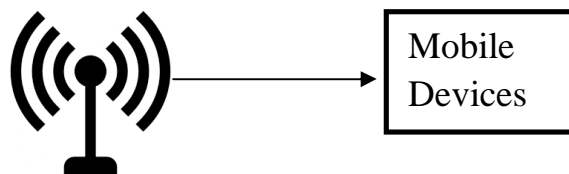

The receiving section may be made up of any devices such as computers, laptops and other portable devices that are connected to the sever and these devices show us the amount of voltage produced and the process occurring in the dam section so that we can be able to monitor the dam from anywhere in the world.

IV. LITERATURE SURVEY

A. *Reginald Juan Magpantay Mercado Developed The Design Of Wireless Sensor Networks Using Embedded Programmable System-On-Chip (Psoc) That Was Applied In The Community-Based Flood Early Warning Systems (Cbfews)*

The destinations of this venture were to configuration, create, introduce, and test an independent and unmanned system of successful, reconfigurable, low-control, minimal effort, long separation by multi-bounce, and supportable CBFEWS. This framework intends to screen and distinguish through sensors, and convey early cautioning information by remote telemetry to catastrophe chance decrease focuses^[1].

This gives chance decrease chiefs of nearby networks the basic data and adequate lead-time to influence early cautioning spread; and execute departure of the powerless populace to more secure grounds. CBFEWS is an apparatus intended to help spare lives and properties by sending early admonitions when danger of flooding is up and coming. The CBFEWS organize is a blend of four sorts of stations: Rain-check (RG), Water-level (WL) sensor, Repeater (RP), and Data Center (DC). A typical arrangement of stage is utilized, for example, sunlight based battery control source, an information procurement and telemetry controller, a low power information lumberjack, a computerized handset, a radio wire, and an all-climate instrument lodging and backing. These stations are deliberately introduced in regions where in the gathered information really speak to the attributes of the waterway channels close to the flood-inclined regions.

The information gathered by the PC at every datum focus gives three unmistakable admonitions dependent on hydrographic edge esteems for Alert, Alarm, and Critical dimensions. The DC PC likewise produces a database where diagrams and reports are made; and used by hazard decrease supervisors to successfully design the time.

B. *Yang Jianli, Wu Wanqing has made a study On assessing Marine Organisms Damages Caused By Spilled Oil*

In light of the physical oceanography, sea life science and ecotoxicology, this paper shows a numerical model to survey quantitatively the marine life form harms brought about by oil slick mishaps, which assumes essential job during the time spent guaranteeing sea discretions and remunerations.

At that point the model is utilized to figure the death rate of various sort marine living beings comparing to various water profundity 4 days after the "Tasman Sea" oil slick mishap in Bohai bay^[2]. At present, quantitative oil slick harm appraisal isn't develop, the harm evaluation of oil slick on marine living beings basically centered around the exploratory techniques, which estimating the poisonous impact of different oils on some basic creatures and announcing the toxin degree with semi-deadly focus and other parameters. Semi-deadly fixation (LC50) is the grouping of spilled oil which makes the death rate of marine life forms accomplish 50%. Seabirds, some mammalian will be solidified to death because of loss of protection capacity in the wake of being in contact with spilled oil.

The dangerous impacts will accomplish as far as possible inside 4 days for most oil, so the 96h LC50) is normally utilized as the reference an incentive for count results which shift with time. Unavoidable plausibility of oil slicks, when they are dirtying condition, expands due to the expanding development of oil industry (working of components for oil extraction, developing number of petroleum stations, engine transport, route) and rising ease of use of oil and its items in different ways. It makes a great deal of issues: starting from monetary harm to impacts on untamed life or loses of tasteful view. Different tidy up innovations are utilized for recouping oil slicks. Scattering is one of them. Dispersive measures (dispersants) - are substances that break oil spill into little beads.

C. *Eric J. Berkenpas, Bradley S. Henning developed A Bioyancy-Controlled Largangian Camera Platform Forin Situimaging Of Marine Organisms In Midwater Scattering Layers.*

This paper displays the structure, advancement, and field aftereffects of an independent, profound submergence, profundity controlled Lagrangian camera stage.

Called the "Driftcam," this moderately little framework has been created to uninhibitedly test midwater acoustic-dissipating layers while being utilized in mix with dynamic acoustics on a close-by research vessel. The framework utilizes a low-light camcorder and brightening framework introduced inside a cleaned borosilicate round lodging. A tale lightness motor, utilizing weight input control, encourages dynamic profundity remedy to a most extreme profundity of 1500 m. Inserted PCs direction the camera, lighting, and profundity control^[3]. The vehicle is an acoustic modem for bidirectional correspondence to the surface delicate. Radio bearing finding and an Argos satellite signal guide in surface recuperation.

Also, the framework is exceedingly compact, estimating 1.5 m in all out length with a mass of 85 kg, and can possibly expand the visual inspecting of midwater networks by lessening operational expenses. All parts of the framework are talked about with center given to configuration, testing, and execution of the lightness motor. Fundamental outcomes are likewise exhibited for organizations into dissipating layers in the Guaymas Basin of the Gulf of California, Mexico, appearing utility of the Driftcam framework in the field.

D. Ken Ishii, Kouichi Sawada developed a project named as Transducer Positioning System with Sights Of Multiple Optical Beams For Target Strength Measurements Of Marine Organisms

Data on target quality (TS) is imperative to the acoustic estimation of the current biomass of the vital little maritime living beings. These sorts of target are lower in reverberation level, and more unpredictable fit as a fiddle than fish. We built a TS estimation framework thinking about these qualities. A live target was suspended and fixed in seawater, and a transducer turned by a stage edge around the objective on a level plane. Specifically it has been stacked on a level plane and vertically with different optical bar gadgets to watch the example angles^[4]. TS estimations of Euphausia pacifica were performed in 2006 utilizing an ultrasonic recurrence of 200 kHz. Somewhat tendency was seen in the flat line type shaft. In vertical pillars no tendency was watched. The mistake of TS esteems because of this tendency was admissible on a functional premise in correlation with the shaft width of the ultrasonic transducer.

V.COMPONENTS

1) *Raspberry Pi*: The Raspberry Pi 3 Model B is the third era Raspberry Pi. This amazing Mastercard estimated single board PC can be utilized for some applications and overrides the first Raspberry Pi Model B+ and Raspberry Pi 2 Model B. While keeping up the famous board group the Raspberry Pi 3 Model B presents to you an all the more dominant processor, 10x quicker than the original Raspberry Pi. Also it includes remote LAN and Bluetooth availability making it the perfect answer for incredible associated plans. The Raspberry Pi is created in the United Kingdom by the Raspberry Pi Foundation to advance the instructing of essential software engineering in schools and in creating nations. A few ages of Raspberry Pi is have been discharged. The original (Raspberry Pi 1 Model B) was discharged in February 2012. It was trailed by a more straightforward and modest model - Model A. In 2014, the establishment discharged a board with an improved plan in Raspberry Pi 1 Model B+. These sheets are around charge card measured and speak to the standard mainline structure factor. Improved A+ and B+ models were discharged a year later. A "register module" was discharged in April 2014 for implanted applications and a Raspberry Pi Zero with littler size and diminished info/yield (I/O) and universally useful information/yield (GPIO) abilities. The Raspberry Pi 2 has more RAM.

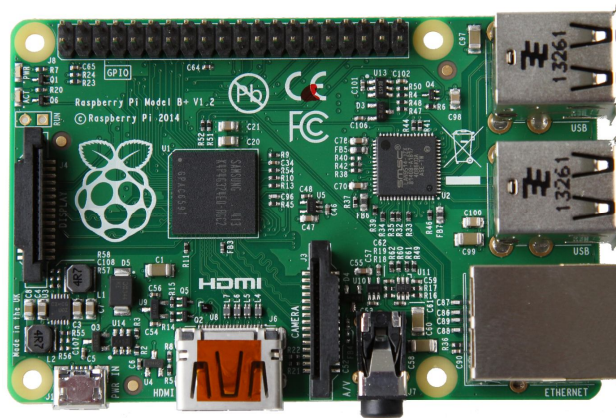

2) *Voltage Sensor*: The Voltage Sensor square speaks to a perfect voltage sensor, that is, a gadget that changes over voltage estimated between two points of an electrical circuit into a physical flag relative to the voltage. Associations + and are electrical preserving port s through which the sensor is associated with the circuit. Association V is a physical flag port that yields the estimation result.AC voltage sensor works as indicated by Magnetic Modulation and is intended for AC voltage estimation. The yield flag of this sensor is corresponding to the info AC voltage. It very well may be utilized for nonstop air conditioning voltage checking of the framework.



3) *Rotor*: The connection between torque versus speed and current is direct; as the heap on an engine builds, speed will diminish. For whatever length of time that the engine is utilized in the region of high productivity long life and great execution can be normal. In any case, utilizing the engine outside this range will result in high temperature rises and crumbling of engine parts. An engine's fundamental rating point is somewhat lower than its most extreme effectiveness point. Burden torque can be controlled by estimating the current drawn when the engine is joined to a machine whose real burden esteem is known .Geared dc engines can be characterized as an augmentation of dc engines. An adapted DC Motor has an apparatus gathering appended to the engine. The speed of engine is included regarding revolutions of the pole every moment and is named as RPM .The apparatus get together aides in expanding the torque and lessening the speed. Utilizing the right mix of apparatuses in a rigging engine, its speed can be decreased to any alluring figure. This idea where gears lessen the speed of the vehicle however increment its torque is known as rigging decrease. A DC engine can be utilized at a voltage lower than the appraised voltage. However, beneath 1000 rpm, the speed ends up precarious, and the engine won't run easily.



4) *Driver Circuit*: The ULN2003 is a solid high voltage and high current Darlington transistor clusters. It comprises of seven NPN Darlington sets that include high-voltage yields with regular cathode clip diode for exchanging inductive burdens. The authority current rating of a solitary Darlington pair is 500mA. The darlington sets might be paralleled for higher current capacity. Applications incorporate hand-off drivers, hammer drivers, light drivers, show drivers (LED gas release), line drivers, and rationale supports. The ULN2003 has a 2.7kW arrangement base resistor for each Darlington pair for task straightforwardly with TTL or 5V CMOS gadgets.

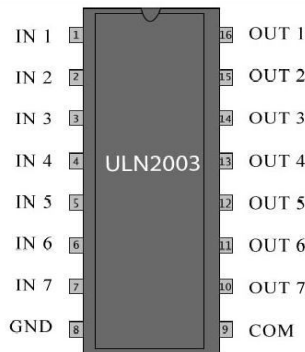

5) *Water Pump Motor*: As the name infers, water siphons siphon water. Regardless of whether that be in a vehicle, at a business, in the home, or in a well, customers can most likely discover a water siphon to accommodate their vehicle or to enable them to draw water starting from the earliest stage a self-dove well to be utilized in weight tanks inside the area. Vehicle water siphons help direct the stream of water through a vehicle's cooling framework; when the seal on these turn sour, the entire siphon must be supplanted. Situated inside the home or business, weight water siphons direct the water weight all year, controlling water stream to various territories of the location.A siphon engine is a DC engine gadget that moves liquids. A DC engine changes over direct flow electrical power into mechanical power. DC or direct current engine takes a shot at the essential, when a current conveying conductor is set in an attractive field, it encounters a torque and tends to move. This is known as motoring activity. Siphons work by some component (ordinarily responding or revolving), and devour vitality to perform mechanical work by moving the liquid. Siphons work through numerous vitality sources, including manual activity, power, motors, or wind control, come in numerous sizes, from minuscule for use in therapeutic applications to substantial modern siphons.



- 6) *Solenoid Valve*: A solenoid valve is an electromechanically worked valve, which is constrained by an electric flow through a solenoid. It tends to be utilized to control the water stream and to quantify the water level. Solenoid esteem offers quick and safe exchanging, high dependability, long administration life, great medium similarity of the materials utilized, low control power and minimized design. The sensor detects the procedure towards the outlet side of the solenoid valve. When it detects that specific amount of the stream of the liquid is required, it enables the current to go through the solenoid valve. Because of this the valve gets empowered and the attractive field is produced which triggers the development of the plunger against the activity of the spring. Because of this the plunger moves in upwards heading, which permits the opening of the hole. At right now the stream of the liquid is permitted from the delta port to the outlet port. At the point when the sensor detects that the liquid is not any more required simultaneously, it stops the stream of the current to the solenoid valve totally. Because of this the solenoid valve gets de-invigorated and the plunger achieves the base most position and shuts the hole totally therefore preventing the stream of liquid from the delta port to the outlet port.



VI.ADVANTAGES

- A. It has both automated and semi-automated process.
- B. It is very cheap and very efficient method for safeguarding aqua organisms.
- C. Reduce maintenance difficulties in the existing system

VII.DISADVANTAGES

- A. The range of monitoring is small for the device to monitor the aqua organisms.
- B. It is not so efficient working under the water.

VIII.APPLICATIONS

- A. It tends to be executed in the dam territories to screen and defend the water creatures.
- B. It creates more measure of vitality utilizing this framework
- C. It can also be used in the other areas to protect aqua organisms.

IX.FUTURE ENHANCEMENT

It tends to be upgraded to screen for a long scope of separation and discover the water living beings coming and control the procedure as needs be and furthermore we should make the gadgets work effectively under the water moreover.

X.CONCLUSION

By utilizing this framework it very well may be demonstrated that it safe watches the water life forms and screens them if the enter the threat zone it has been alarmed to the checking area and furthermore in the meantime it keeps the loss of water life form by shutting the solenoid valve. In this way proposed task is done to expand the effectiveness of the vitality delivered and furthermore spare the water lives.

REFERENCES

- [1] [1] Ruan Guoping, Reason Analysis and Corresponding Strategy for Cooling Water Intake Blockage at Nuclear Power Plants, Nuclear Power Engineering, 2015(36)s1:151-154.D. Z.
- [2] [2] Zhang Yong 1 , Zeng Lan1, 2 , Wu Bingfang□Index systems for regional food security early warning. Transactions of the CSAE, 2004, 20(3):192-196.
- [3] [3] Koyuncugil A S, Ozgulbas N. Finacial early waring system model and data mining application for risk detection[J]. Expert systems with Applications, 2012,39(6):6238-6253.
- [4] [4] Reginald Juan Magpantay Mercado. Design of wireless sensor networks using embedded Programmable System-on-Chip (PSoC) as applied to community-based flood early warning systems (CBFEWS)[C], 2016 International Conference on Advances in Electrical, Electronic and Systems Engineering (ICAEEES). Putrajaya, Malaysia , 14-16 Nov. 2016 : 214 – 223.
- [5] [5] Luca Cenci, Paola Laiolo, Simone Gabellani, Lorenzo Campo, Francesco Silvestro, Fabio Delogu, Giorgio Boni, and Roberto Rudari. Assimilation of H-SAF Soil Moisture Products for Flash Flood Early Warning Systems. Case Study: Mediterranean Catchments. IEEE Geoscience & Remote Sensing Society. 2016, 9(12): 5634 - 5646
- [6] [6] QU Zhong qiong, ZHANG Ming, YU Xiao.Comparative Study on Single Early Warning of TwoTransforming Modes of Urban and Rural ConstructionLand. JOURNAL OF SHANDONG AGRICULTURAL UNIVERSITY (Social Science Edition) , 2015(4):84-89.
- [7] [7] ZHANG Xing lian, ZHANG Hui yuan, TANG Xiao chun, QIAN Yong zhong, LI Xiao man. Research on the early-warning model of vegetable pesticide residues based on a neural network[J]. Journal of Agricultural University, 2015, 20(2): 259-267.
- [8] [8] WANG Ying, JIANG Gaopeng. Coal mine safing risk prediction by RS-SVM combined model[J]. Journal of China University of Mining & Technology, 2017, 46(2): 423-429.
- [9] [9] LI Xue ding, ZENG Yin dong, REN Zan chang, ZHANG Chun gui, GUO Minquan[J]. Application of red tide forecasting system of Fujian. MARINE FORECASTS, 2017, 46(2): 423-429.

IEEE conference templates contain guidance text for composing and formatting conference papers. Please ensure that all template text is removed from your conference paper prior to submission to the conference. Failure to remove template text from your paper may result in your paper not being published.

We suggest that you use a text box to insert a graphic (which is ideally a 300 dpi TIFF or EPS file, with all fonts embedded) because, in an MSW document, this method is somewhat more stable than directly inserting a picture.

To have non-visible rules on your frame, use the MSWord “Format” pull-down menu, select Text Box > Colors and Lines to choose No Fill and No Line.



10.22214/IJRASET



45.98



IMPACT FACTOR:
7.129



IMPACT FACTOR:
7.429



INTERNATIONAL JOURNAL FOR RESEARCH

IN APPLIED SCIENCE & ENGINEERING TECHNOLOGY

Call : 08813907089  (24*7 Support on Whatsapp)