



iJRASET

International Journal For Research in
Applied Science and Engineering Technology



INTERNATIONAL JOURNAL FOR RESEARCH

IN APPLIED SCIENCE & ENGINEERING TECHNOLOGY

Volume: 7 Issue: III Month of publication: March 2019

DOI: <http://doi.org/10.22214/ijraset.2019.3214>

www.ijraset.com

Call:  08813907089

E-mail ID: ijraset@gmail.com

Industrial Accident Prevention and Hybrid Pollution Control System

Sharmila R¹, Sripavithra P², Dhinesh M³, Gunasekar T⁴

^{1, 2, 3}UG Scholars, Department of EEE, Kongu Engineering College

⁴Assistant Professor, Department of EEE, Kongu Engineering College

Abstract: *The objective of the paper is to prevent the pollution mainly present in air and water and also to detect the electric current flow through the conductor when the supply is turned off. Nowadays, worker's safety and surrounding environmental protection is more important in all kind of industries.*

Even though there is a usage of PPE (Personal Protective Equipment) in industries, the death of workers by electrocution and gas leakage is not yet controlled.

Thus, the various sensors are used to sense the various parameters such as quantity of smoke delivered from the industries, wastages along with water and to detect the electricity leakages.

The output of sensors given to the microcontroller and the message is sent to the industries and to the government through GSM module. This paper is mainly to sense the contamination of air along with water and to prevent accidents while working in the live wires.

Keywords: *PPE, Microcontrollers, GSM modules*

I. INTRODUCTION

The life of the workers and environmental protection are the most important factor for all types of industries. Now a days, the development of new industries and upgrading of industries increases day by day. But some industries do not bother about the life of workers and environment as they only think about their development only.

Though there is the usage of Personal Protective Equipments (PPEs) like glouses, googles etc for the outer protection, the industries did not able to give full protection to the public because of sudden unknown electrical leakages from any part of the conductors. So, to avoid such kind of problems, this paper is by sensing the flux produced by the leakage current from the conductors and to give the alert signals. It is to prevent the worker's from the accident by electrocution. And also, now a days 60% of our environment is affected by industries.

As the industrialization increases, the degree of automation turns to increase and at the same time it increases the pollution. So, the industrial monitoring is must to prevent the ecosystem.

To protect the environment, this paper is designed to measure the pollutants quantity, if it exceeds above the pre-specified limit which affects the environment is measured and the control signal is send to the microcontroller. Then, by using GSM module the message will be send to industries to take the necessary steps. If they do not take any steps then the message will be send to government to cancel the license of that respective industry.

II. LITERATURE SURVEY

The proposed paper deals with the pollution monitoring sensors along with programmed microcontroller to control pollution and emf detector to sense the conduction in un-energized conductor.

The paper proposed by Ms. Isha Gupta and Ms.

Rashpinder Kaur, discussed about the pollution monitoring not to take any controlling actions and the sensors requirement are high because they have used a particular sensor for measuring a particular pollutant and also the work was implemented using the platform of LabVIEW software where interfacing of hardware is available.

The paper proposed by J.Mythily and P.Balaji explained the usage of software LABVIEW which was costlier and it could be used only within the laboratory. To overcome these disadvantages from these literatures, it is proposed to use PIC microcontrollers, GSM and two sensors one for air pollution monitorization and another for water pollution.

III. BLOCK DIAGRAM

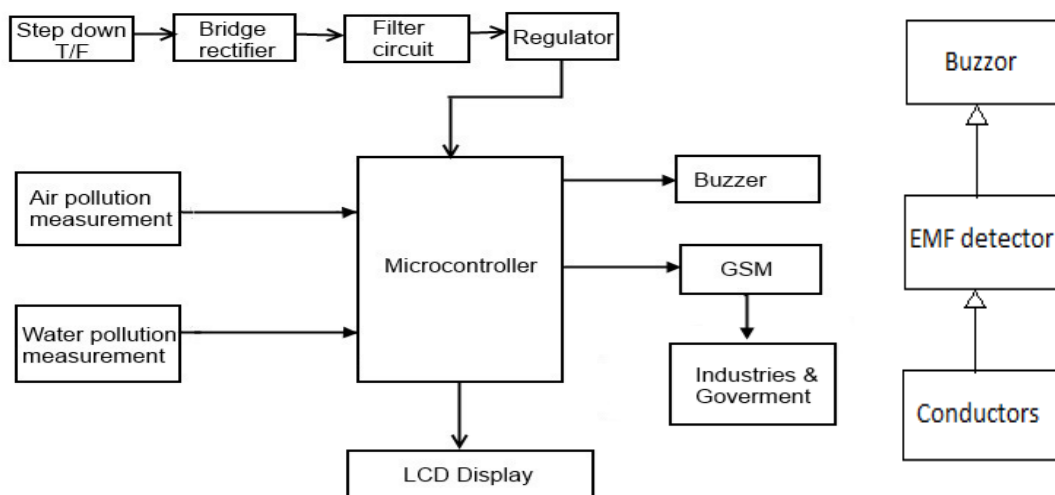

Figure 1 Block Diagram of Pollution Control System and Accident Prevention

A. Components Required

The components used to develop this model is given below:

Air pollution sensor	:	MQ 3
Water pollution sensor	:	pH sensor
Microcontroller	:	ATMEGA8A-PU (1740)
GSM module	:	M590E GSM/GPRS BOARD
Trans Receiver	:	MAX232N
Step down transformer	:	0.5Amps
Voltage Regulator	:	BEL7812,BEL7805
Diode	:	IN40073
Resistor	:	10k , 1k
LCD	:	16*2 display

IV. WORKING

Hybrid pollution control system is built by using air pollution sensor MQ-3 and water pollution sensor pH sensor to sense the parameters to monitor the environmental pollution. Air pollution sensor is used to measure the quantity of polluted content in air. The content that the sensor mostly preferred to sense are carbon monoxide and carbon dioxide. And for water pollution monitoring system, the pH sensor is connected or kept at water outlet from the industries. It will check the acidity and alkalinity of the water. If the acidity of the outlet water increases then pH value of the sensor also turns to increase. The air pollution measurement sensor MQ-3 sensor and pH sensor connected to the ATMEGA8A microcontroller in pollution monitoring system. The microcontroller gets power supply from power supply circuit. The power supply circuit comprises of step down transformer, bridge rectifier, filter circuit and regulator. The GSM module is used here to transmit the information about the pollution level to the pollution control authorities in industries . The air pollution sensor measures the change in pollutant value in terms of voltage and for water pollution it is in terms of current. If the value of MQ3 greater than 2.5V and pH sensor value greater than the normal acidic environment that is greater than 7 then the air and water are considered as pollutant. Based on those output the control signal will be generated . According to the control signal , the message will be send to the industries through the GSM module to take necessary actions . For the worker's protection , the EMF detector is used to sense the flux produced by the current passing through the conductors when the supply is in OFF condition due to any fault or shorting with other conductors. It works on the principle of Faraday's law of mutual induction because the current in the conductor changes then the EMF will be developed in the EMF detector is measured . If there is current flow then the EMF developed which is supplied as input to the buzzer to give alter the workers . In this paper, it is done by using coil which is possible to trace the flux up to 20-25cm.

V. HARDWARE IMPLEMENTATION

The hardware setup of the hybrid pollution monitoring system is shown in the Figure 2. The air pollution sensor placed at the top of the industries where the outlet of smoke is situated, connected to the controller via the driver circuit and the pH sensor placed at the outlet of industrial waste water is connected to the controller directly. The supply to the microcontroller turned ON then the value of sensors are shown in LCD display. If the value of air pollution exceeds 300 and pH sensor value exceeds 7, the message will be sent to the owner then to the government. This paper is executed by using the lighter which produce smoke and the wastewater from industries.



Figure 2 Hybrid Pollution Monitoring System

The hardware setup of Accident Prevention System is shown in Figure 3. This setup is designed as proximity device in which coil is used to sense the flux produced by the current carrying devices when the supply is turned OFF. If the change in flux produced in the coil then the EMF is induced, the buzzer will give the sound to prevent the worker from touching the shorted wire. It will work for 20-25 cm.



Figure 3 Accident Prevention System

VI. CONCLUSION

Thus this paper was successfully implemented by using embedded C program coding damped into the ATMEGA8A and the sensors along with GSM module for transmitting the messages to the authority for hybrid pollution control. Accident prevention is achieved by the usage of coil to sense the flux produced from the conductor.

VII. FUTURE SCOPE

The future scope of Hybrid Pollution Control System is the usage of the recycle part at the end of the circuit. If the values exceed then the recycle of water and air can be done and the wastages can be removed separately. The future scope of Accident Prevention System is that replace the coil by any other sensors to extend the distance.

The field of pollution monitoring and control is very wide and this is an attempt to monitor and regular inspections by the utility of Global System for Mobile communications. For alleviating these problems, advanced GSM system with microcontroller is used. The performance and remotely the pollution monitoring and control system can further be improved by implementing sensors for controlling dust, noise, smoke and other parameters, thereby improving the industrial and natural environment.

REFERENCES

- [1] Jacob Millman Christos C. Halkias.: " Electronics Devices and Circuits", Tata McGraw-Hill Publishing Company Ltd published on Sep, 2003.
- [2] Sawhney, A.K.: "Electrical and Electronic Measurements and Instruments", Dhanpat Rai & Co. 2003.
- [3] Shive, J.N.: "Semiconductor Devices", chap 8&9, D. Van Nostrand Inc. Princeton, N.J., 1959.
- [4] H. Karl, A. Willig, " Protocols and Architectures for Wireless Sensor Networks", Southern Gate, Chichester, West Sussex, England: John Wiley and Sons Ltd, The Atrium, 2005.
- [5] Nihal Kularatna, B. H. Sudantha, "An Environmental Air Pollution Monitoring System Based on the IEEE 1451 Standard for Low Cost Requirements", IEEE Sensors Journal, vol. 8, no. 4, 2008.
- [6] Saba A. Hanna, Yuichi Motai, "Very-Low-Frequency Electromagnetic Field Detector With Data Acquisition" on the IEEE transactions on instrumentation and measurement, vol. 58, no. 1, January 2009.
- [7] Asubiojo, O.I., Aina, P.O., Oluwole, A.F., Arshed, W., Akanle, O.A. and Spyrou, N.M. (1991), "Effects of cement production on the elemental composition of soils in the neighborhood of two cement factories, Water, Air, and Soil Pollution", Vol. 57-58, pp. 819-828.
- [8] Abdel-Halim, A. S., Metwally, E. and El-Dessouky, M. M. (2003), "Environmental pollution study around a large industrial area "near Cairo, Egypt, Journal of Radio analytical and Nuclear Chemistry, Vol. 257, No. 1, pp.123-124.



10.22214/IJRASET



45.98



IMPACT FACTOR:
7.129



IMPACT FACTOR:
7.429



INTERNATIONAL JOURNAL FOR RESEARCH

IN APPLIED SCIENCE & ENGINEERING TECHNOLOGY

Call : 08813907089  (24*7 Support on Whatsapp)