



# **iJRASET**

International Journal For Research in  
Applied Science and Engineering Technology



---

# **INTERNATIONAL JOURNAL FOR RESEARCH**

IN APPLIED SCIENCE & ENGINEERING TECHNOLOGY

---

**Volume: 7      Issue: III      Month of publication: March 2019**

**DOI: <http://doi.org/10.22214/ijraset.2019.3292>**

**[www.ijraset.com](http://www.ijraset.com)**

**Call:  08813907089**

**E-mail ID: [ijraset@gmail.com](mailto:ijraset@gmail.com)**

# Design and Fabrication of Rotating and Tilting Vice (New Technique) for Radial Drilling Machine

P. Rajendra Babu<sup>1</sup>, Ch. Mani Kumar<sup>2</sup>, K. Daniel<sup>3</sup>

<sup>1</sup>Asst. Professor, Dept of Mechanical Engineering, Sasi Institute of Technology & Engineering(Autonomous), Tadepalligudem, W.G, AP, India.

**Abstract:** Radial drilling machines are very use full in industries to generate hole, internal threads on components. Present industries the normal radial drilling machines are available; by using those machines we cannot generate some operations. Some of the difficulty operation not performed by such type of radial drilling machines. Radial drilling machine used to drill the fixed jobs only. Here we prepossess rotating and tilting machine vice. Rotating and tilting vice have been designed by using SOLIDWORKS. Fabrication is carried out trough different joining methods. The proposed machine vice is very useful to manufacturing processes, especially for producing holes on triangle and cylindrical work pieces at different tilting and rotation positions.

**Keywords:** Vice, Frame stand, round plate, bevel gears, nut and screw arrangement, SOLIDWORKS.

## I. INTRODUCTION

V. V. Saidpatil , S. R. Tanpure , R. M. Rupanawar and T. V. Daundkar (ISSN: 2455-5703): A Bench vice or fixture is a production tool. The main aim is to locate, support and hold the work securely so we can perform the required machining operations. Feeler or thickness gauges and set blocks are also used to provide reference of the cutter with the work piece. A bench vice must be easily fastened with the machine and the table. As a result, the work can be done.

R. Anandhan , P. Gunasekaran , D. Sreenevasan , D. Rajamaruthu (ISSN: 2347-6710): To meet the need of exploding population economic and effective control of machines is necessary. Our project even is rotated to easily drill at any direction. So that job setting operation is not complicated as well as reduces the setting time for the operation. It also takes into consideration the most effective method of controlling the drilling machine by manually. Materials like wood, plastic and light metals can be drilled with this. The work piece is fixed on the work table, which is provided with a moving arrangement.

R.S. Kumar , P.S. Predeep , S.S. raja and C. Rammurugan (ISSN: 2347 – 6710): Tool design is the process of designing and developing the tools, methods, and techniques necessary to improve manufacturing efficiency and productivity. The main objectives of tool design are to lower the manufacturing cost while maintaining the quality and increased production by cutting down time between machining operations. Various parameters that forms the main criterion in the tool design are providing simple, easy-to-operate tools for maximum efficiency, reduction of manufacturing expenses by producing parts at the lowest possible cost, design of tools which consistently produce parts of high quality, increasing the rate of production with existing machine tools, design of tool to make it fool proof and prevent improper use, selection of materials that will give adequate tool life Tooling refers to the hardware necessary to produce a particular component.

M .Shrikant M. Chougule and D. B. Waghmare (ISSN 2319 – 4847): Prototyping or model making is one of the important steps to finalize a product design. Traditional Rapid Prototyping (RP) is commonly referred to as layered manufacturing or solid free form fabrication. It is used for the physical modelling of a new product design directly from computer aided design (CAD) data without the use of any special tooling or significant process engineering.

C. Anuchandran , M. Praveen , R. Karthikeyan and R. Arun ( ISSN : 2321-0613): An incredible range of manufacturing systems use the force and power of fluids such as water, oil and air. Powered clamps open and close with the force of pressurized air or oil, large presses clear shape and form metal with hydraulic pressure and assembly torque tools fasten components with pressurized air. In each example, Fluid power provides the energy necessary to exert significant mechanical forces.

U. Deepak, C. Tharun Prabhakar, P .M. Prasanth, S. Manikandan: Productivity depends upon many factors, one of the major factors being manufacturing efficiency with which the operation /activities are carried out in the organization. Productivity can be improved by reducing the total machining time, combining the operations etc. In case of mass production where variety of jobs is less and quantity to be produced is huge, it is very essential to produce the job at a faster rate.

J.Russell, J.J. Baur (April, 1999): A vise having machinable low profile removable jaws includes a stationary jaw attached between two movable jaws for holding two work pieces during a machining process. The stationary jaw is positioned adjacent to a pair of guide rails, which are mounted onto a base. The movable jaws are removable attached to a first and second slide member by a mating connection which is positioned below the work surface of the vise.

## II. DESIGN ASPECTS

- 1) *Introduction SOLIDWORKS Software:* The SOLIDWORKS & CAD software is a mechanical design automation application that lets designers quickly sketch out ideas, experiment with features and dimensions, and produce models and detailed drawings. This document discusses concepts and terminology used throughout the SOLIDWORKS application. It familiarizes you with the commonly used functions of SOLIDWORKS commands on it.
- 2) *3D Design of Object:* SOLIDWORKS uses a 3D design approach. As you design a part, from the initial sketch to the final result, you create a 3D model. From this model, you can create 2D drawings or mate components consisting of parts or subassemblies to create 3D assemblies. You can also create 2D drawings of 3D assemblies. When designing a model using SOLIDWORKS, you can visualize it in three dimensions, the way the model exists once it is manufactured.

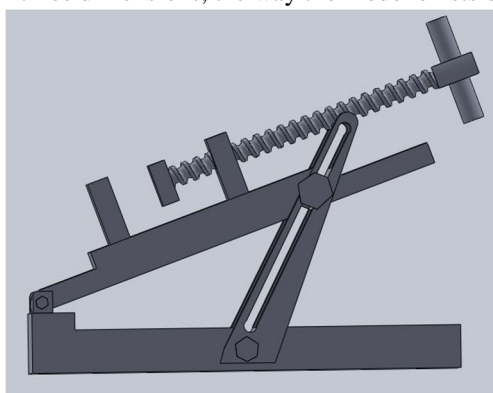

Fig. 2.1 Tilting vise

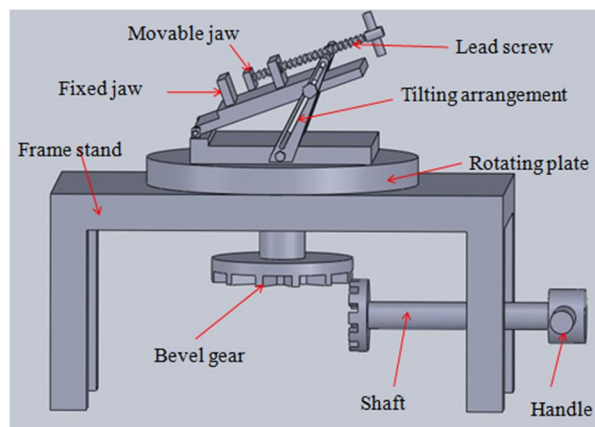

Fig. 2.2. Proposed model of tilting & rotating vise

- 3) Design Process: The design process usually involves the following steps:
  - a) Identify the model requirements.
  - b) Conceptualize the model based on the identified needs.
  - c) Develop the model based on the concepts.
  - d) Analyze the model.
  - e) Prototype the model.
  - f) Construct the model.
  - g) Edit the model, if needed.

### III. FABRICATION WORK

- 1) **Welding:** Welding is a fabrication or sculptural process that joins materials usually metals or thermoplastics, by causing fusion, which is distinct from lower temperature metal-joining techniques such as brazing and soldering, which do not melt the base metal. In addition to melting the base metal, a filler material is typically added to the joint to form a pool of molten material (the weld pool) that cools to form a joint that is usually stronger than the base material. Pressure may also be used in conjunction with heat, or by itself, to produce a weld. Welding also requires a form of shield to protect the filler metals or melted metals from being contaminated or oxidized.
- 2) **Drilling:** Drilling is a cutting process that uses a drill bit to cut a hole of circular cross-section in solid materials. The drill bit is usually a rotary cutting tool, often multipoint. The bit is pressed against the work piece and rotated at rates from hundreds to thousands of revolutions per minute. This forces the cutting edge against the work piece, cutting off chips (swarf) from the hole as it is drilled.
- 3) **Grinding:** Grinding is an abrasive machining process that uses a grinding wheel as the cutting tool. Grinding practice is a large and diverse area of manufacturing and tool making. It can produce very fine finishes and very accurate dimensions; yet in mass production contexts it can also rough out large volumes of metal quite rapidly. It is usually better suited to the machining of very hard materials than is "regular" machining (that is, cutting larger chips with cutting tools such as tool bits or milling cutters), and until recent decades it was the only practical way to machine such materials as hardened steels. Compared to "regular" machining, it is usually better suited to taking very shallow cuts, such as reducing a shaft's diameter by half a thousandth of an inch or 12.7  $\mu\text{m}$ .
- 4) **Selection of Materials**
  - a) **Material for vice: Cast Iron**

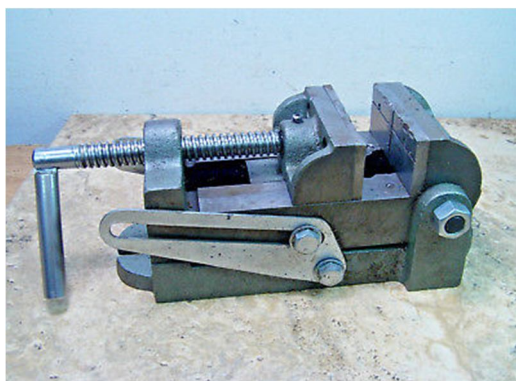

Fig. 3.1 Tilting Vice

Table. 3.1. Comparative qualities of cast irons

Name	Nominal composition [% by weight]	Form and condition	Yield strength [ksi (0.2% offset)]	Tensile strength [ksi]	Elongation [% (in 2 inches)]	Hardness [Brinell scale]	Uses
Grey cast iron (ASTMA48)	C 3.4, Si 1.8, Mn 0.5	Cast	—	50	0.5	260	Engine cylinder blocks, flywheels, gearbox cases, machine-tool bases
White cast iron	C 3.4, Si 0.7, Mn 0.6	Cast (as cast)	—	25	0	450	Bearing surfaces
Malleable iron (ASTM A47)	C 2.5, Si 1.0, Mn 0.55	Cast (annealed)	33	52	12	130	Axle bearings, track wheels, automotive crankshafts

- b) *Material for vice jaws:* Steel is an alloy of iron and carbon and other elements. Because of its high tensile strength and low cost, it is a major component used in buildings, infrastructure, tools, ships, automobiles, machines, appliances, and weapons.
- c) *Material for frame stand:* Aluminium



Fig. 3.2 Frame stand

Table. 3.2. Properties for Aluminium.

Property		Value
Atomic Number		13
Atomic Weight (g/mol)		26.98
Valency		3
Crystal Structure		FCC
Melting Point (°C)		660.2
Boiling Point (°C)		2480
Mean Specific Heat (0-100°C) (cal/g.°C)		0.219
Thermal Conductivity (0-100°C) (cal/cms.°C)		0.57
Co-Efficient of Linear Expansion (0-100°C) (x10 <sup>-6</sup> /°C)		23.5
Electrical Resistivity at 20°C (Ω.cm)		2.69
Density (g/cm <sup>3</sup> )		2.6898
Modulus of Elasticity (GPa)		68.3
Poisson's Ratio		0.34

d) *Construction*

- i) Take aluminium square pipes, cut it for required length by using grinder cutting machine.
- ii) Grinding it for good surface finish.
- iii) Making a frame stand with suitable dimensions by using shield metal arc welding.
- iv) Place the iron plate above the frame stand and weld that plate by using metal arc welding.
- v) Cut a slot in cast iron plate by using gas welding for fitting shaft to the rotating plate.
- vi) In the top of frame stand, movable jaw and fixed jaw arrangements are fitted with suitable adjustment.
- vii) Grinding to the welding places by hand grinder cutting machine.
- viii) Bottom of the frame stand the Bevel Gear arrangement can be fitted by using welding with the support of shaft.
- ix) The two grippers are placed opposite face of vice.



Fig. 3.3 Fabricated model of Rotating and Tilting vice

- 5) Advantages of Rotating and Tilting Vice
  - a) Less time taken for holding a work piece.
  - b) Easy to handle.
  - c) Unskilled operator also operates easily.
  - d) Increasing production rate.
  - e) Tilt the vice up to 90 degrees.
- 6) Applications of Rotating and Tilting Vice
  - a) *Drilling*: It is a cutting process that uses a drill bit to cut a hole of circular cross-section in solid materials. The drill bit is usually a rotary cutting tool, often multipoint. The bit is pressed against the work piece and rotated at rates from hundreds to thousands of revolutions per minute.
  - b) *Joining*: Brazing is a joining process in which a filler metal is melted and drawn into a capillary formed by the assembly of two or more work pieces. The filler metal reacts metallurgically with the work piece and solidifies in the capillary, forming a strong joint. Unlike welding, the work piece is not melted.
  - c) *Cutting*: On hacksaws, as with most frame saws, the blade can be mounted with the teeth facing toward or away from the handle, resulting in cutting action on either the push or pull stroke. In normal use, cutting vertically downwards with work held in a bench vice, hacksaw blades are set to be facing forwards.
  - d)

#### IV. CONCLUSION

- A. The radial drilling machine can be used to drill the fixed job with higher efficiency. But it cannot rotate or tilt the job at particular angle.
- B. To overcome the above problem, we fabricated rotating and tilting vice to rotate the work piece with the help of bevel gear train mechanism and tilt the vice up to 90 degrees with the help of bolt and nut.
- C. Design process is achieved by relying on new design method and with the help of computer software like SOLIDWORKS.
- D. The need of modifications in actual design is to reduce overall cost of the product, increase the products life, minimizing material waste etc. These are achieved in the modifications of bench vice.

#### REFERENCES

- [1] V. V. Saidpatil, (2016) "Design and Modification of Bench Vice by Increasing the Degrees of Freedom". Volume 1, pp. 21-24.
- [2] R.Anandhan, (2016) "Design and Fabrication of Angular Drilling Machine". Volume 5, pp. 88-95.
- [3] R.S.Kumar (2015) "Optimizing the Method of Work Holding Device-Drill Jig with Adjustable Drill Bush". Volume 4, pp. 561-564.
- [4] P. Newswanger, (1973) "Fabrication of Bench vice" International Journal of Design and Manufacturing technology (IJDMT), Volume 6, Issue 2.
- [5] D. Attarde, " Design and Fabrication of Grinding Wheel Attachment on LatheMachine", International Journal of Mechanical Engineering and Technology(IJMET), vol:1 Issue 02, July – 2016.
- [6] M. Ranjithkumar " Design and analysis of manually operated floor cleaning machine", vol:2 Issue 16, March – 2015.
- [7] F. Béтин, " Design for Electrical Machines" International Journal of Electrical Engineering & Technology , vol:1 Issue 22, August– 2016.
- [8] A.Javidinejad, " Structured Teaching of Machine Design for Future Design Engineers", International Journal of Mechanical Engineering and Technology, 3(2), 2012, pp. 120–127.
- [9] C. Anuchandran, " Design & Fabrication of Bench vice" International Journal of Application or Innovation in Engineering & Management, Volume 4, Issue 7, July 2015.
- [10] A.S.Kadam, "Design & Fabrication of vices " Department of Mechanical Engineering, Indian Institute of Technology Delhi, Volume 5, Issue 1, June -2012.
- [11] L.Vardhaman, "semi-automatic floor cleaning machine" International Journal of Design and Manufacturing technology(IJDMT), volume 8, Issue 1, January-April 2016.
- [12] Newswange, "Fabrication of Bench vice" International Journal of Design and Manufacturing technology(IJDMT), Volume 6, Issue 2, January 1973.
- [13] Dr. S K Patel has designed and developed a " work holding Vice for the Drilling and milling purpose ", Department mechanical NIT Rourkela vol:2 Issue 05, May – 2013-2014.
- [14] Bench Vice is a holding machine that Machine vices are mounted on grinding machines, drill presses and milling machines.
- [15] P. M. Pandey, "Rapid Prototyping Technologies", Applications and Part deposition planning, Department of Mechanical Engineering, Indian Institute of Technology Delhi. June - 2012.



10.22214/IJRASET



45.98



IMPACT FACTOR:  
7.129



IMPACT FACTOR:  
7.429



# INTERNATIONAL JOURNAL FOR RESEARCH

IN APPLIED SCIENCE & ENGINEERING TECHNOLOGY

Call : 08813907089  (24\*7 Support on Whatsapp)