



IJRASET

International Journal For Research in
Applied Science and Engineering Technology



INTERNATIONAL JOURNAL FOR RESEARCH

IN APPLIED SCIENCE & ENGINEERING TECHNOLOGY

Volume: 7 Issue: IV Month of publication: April 2019

DOI: <https://doi.org/10.22214/ijraset.2019.4284>

www.ijraset.com

Call:  08813907089

E-mail ID: ijraset@gmail.com

Conveyor System to Transfer Fine Powdered Plastic Raw Material into Mixing Machine

Manimaran. C¹, Velmurugan. V², Sedhuraman. L³

^{1,2}Guide, associate professor, Department of Mechanical Engineering, IFET College of Engineering, Villupuram, Tamilnadu, India.

³Student, Department of Mechanical Engineering, IFET College of Engineering, Villupuram, Tamilnadu, India

Abstract: *Plastics plays important role in industries and in our day to day life. It has wide applications at home, vehicles, hospitals and computer manufacturing industries. In plastic manufacturing industries feeding raw materials to mixing machine is most important, and it is manually fed into the machine in some of the industries. It is decided to provide a solution to feed the raw materials with help of automatic feeding system. This project provides a design diagram to feed the raw materials into the mixing machine in PVC manufacturing industries. In this project we are providing a vacuum conveyor system for transferring plastic raw materials into the mixing machine. The purpose of this project is to replace the manual work by automatic process and to reduce the pollution in the industry due to leaking of fine particles of plastic raw materials from the mixing chamber. The closed transfer of raw materials through vacuum conveyor system reduces the pollution by avoiding leakage of dust particles from the mixing machine since the lid is closed while transfer of raw materials. The raw materials are loaded in the hopper which is located in the ground level instead of loading at top of machine. So it reduces the manual work. Hence the project replaces the manual loading of raw materials into automatic process effectively.*

I. PROBLEM IDENTIFIED IN INDUSTRY

During manufacture of PVC pipes the raw materials have to be mixed completely. This mixing process is carried out by a mixing machine. In this mixing machine, the raw materials have to be fed manually at a height of 3 meter. The material weights about 55 kilogram per batch and average time between every batch is 5 minutes. The manual loading of raw material was difficult.

During mixing of raw materials high pressure is created inside the machine. This causes leaking of fine powdered plastic materials during opening of machine lid. The lid has to be opened for every time and it causes pollution inside the industry.

Hence the raw material feeding has to be automated in such a way that manual work should be reduced and pollution inside the industry has to be reduced.

II. LITERATURE SURVEY

A. Dry Solids Continuous Blending And Conveyng Apparatus

(Charles M. Gilman, Gilman, Conn., assignor to The Gil man Brothers Company, Gilman, Conn., a corporation of Connecticut)

The unloading of raw materials from the hopper can be done by screw conveyor. The screw conveyor is driven by an electric motor. This system provides complete falling of raw material into the feeding pipe and then the raw materials are sucked by the vacuum.

1) *Opinion:* In feeding of raw materials into the mixing machine the materials have to be completely transferred into the machine without leaving any materials. The screw conveyor needs additional components and increases the power consumption. This system may block some raw materials.

B. Apparatus For Conveyng Granular Plastic Material

(Gerhard Goth, Benningen (DE))

During feeding of plastic raw material into the mixing machine it is important to transfer the raw material through closed transfer system. It prevent mixing of raw material with the atmosphere as the raw materials are in fine powdered form and prevents from wastage of raw materials.

1) *Opinion:* vacuum conveyor system only provides closed transfer of raw materials

C. Pump C Q2

Air at high pressure to the filter. The passed air removes the particles that are stick on filter pours.

1) *Opinion:* An air compressor is used to pass the pressurized air into the filter to remove the particles on filter.

D. Effects Of An Electrstatic Field In Vacuum Conveying Of Granular Materials Through Inclined And Vertical Pipes (Eldin Wee Chaunlimzang Chi-Hwawang)

During transfer of fine powdered raw materials through pipes the important thing that have to consider is inclination of pipes. The experiments shows various difference in transfer through vertical and inclined pipes. In vertical pipes backflow is high when compared to inclined pipes.

- 1) *Opinion*: Inclined pipes are choosed instead of vertical pipes to reduce backflow and avoid blocking of granular plastic materials.

III. METHODS AVAILABLE

The methods that are mostly used in industries to feed the raw materials into the machine are:

- A. Belt Conveyor System
- B. Vacuum Conveyor System

1) *Belt Conveyor System*



In belt conveyor system the raw materials are fed through rotating belt. To carry out the raw material buckets are attached to the belt. The system is driven by electric motor.

a) Advantages

- i)* Simple calculations and design of system.
- ii)* Low cost.

b) Disadvantages

- i)* There is no complete transfer of raw materials.
- ii)* It occupies more space.
- iii)* Need regular maintenance.
- iv)* This system is not suited for quick feeding of materials.
- v)* The open transfer of raw material is not secure

2) Vacuum Transfer System



In vacuum transfer system high vacuum is used to transfer the raw materials. The vacuum is created through the vacuum pump. The materials are transferred through the conveyor pipes.

1) Advantages

- a) Closed transfer of raw materials.
- b) Quick transfer of materials.
- c) The system occupies less space.

2) Disadvantages

- a) Cost of the components is high.

C. Suitable Method

By studying various advantages and disadvantages, the method that is suitable for conveying fine powdered raw materials is vacuum conveying system. And this system was proposed in industry.

IV. WORKING PRINCIPLE

The materials are transferred into the machine by vacuum pump. High vacuum is created in the vacuum chamber causes suction of material from low level hopper to vacuum chamber. Then the raw materials are fed into the machine from vacuum chamber.

A. Components

- 1) *Vacuum Pump*: Vacuum pump is used to create high vacuum in the vacuum chamber
- 2) *Air Compressor*: Air compressor is used to pass high pressurized air to remove the fine powdered materials that stick over the filter
- 3) *Valves*: Valves are used to control the flow through pipes.
- 4) *Filter*: Filters are used to suck the air inside vacuum chamber to create vacuum
- 5) *Vacuum Chamber*: The raw materials from the hopper are transferred to the vacuum chamber due to high vacuum inside the chamber.
- 6) *Hopper*: The materials are initially loaded into the hopper.

Design Diagram Layout

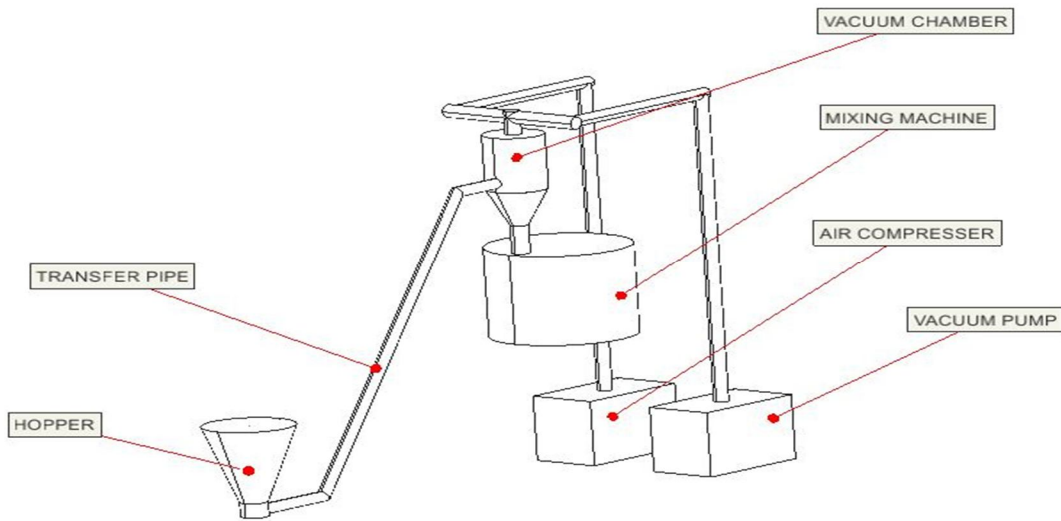

Vacuum Chamber

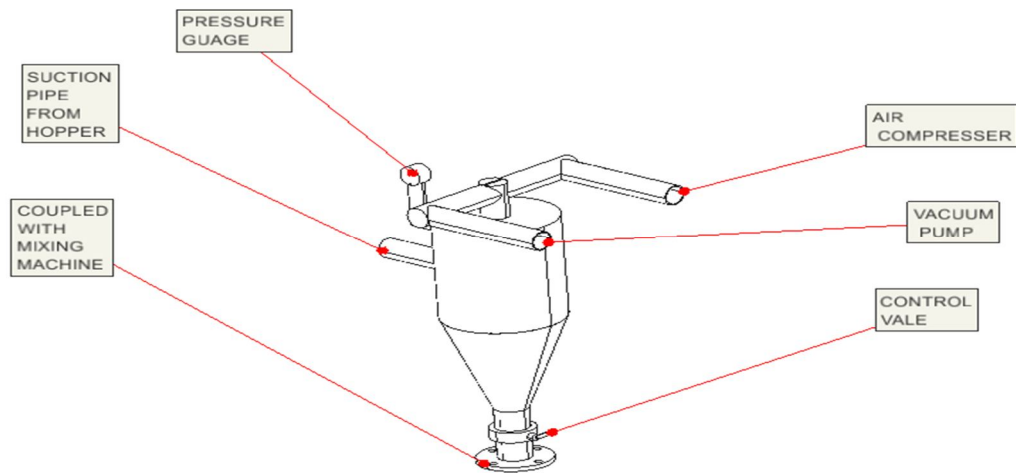

Hopper

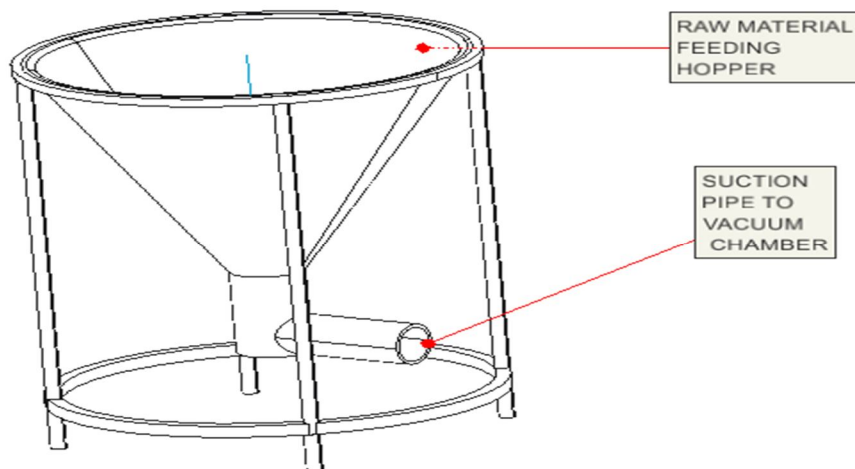

V. METHODOLOGY

- A. The raw materials are initially loaded in the hopper that was kept at ground level for easy loading.
- B. Then the vacuum pump is turned on until required pressure is generated. The pressure level checking was assisted by pressure gauge.
- C. Then valve one opened and the raw materials are sucked from hopper to vacuum chamber.
- D. After the raw materials are sucked then the chamber valves are opened to pour the raw materials into mixing machine.
- E. Then the air compressor valve is opened to remove the particles stick on the filter by passing high pressured air through nozzle.
- F. This process is carried for every cycle of feeding.

VI. CONCLUSION

In industries it is important to reduce the pollution during production Sprocess. And most of the industries are automizing to reduce the manual effort and risk and to increase the productivity. This project reduces the pollution in industry and replaces the manual work into automatic process. This results in increased production and makes the production process safer. During production process in plastic industries it is difficult to transfer the fine powdered raw materials. Thus the vacuum conveyor system is efficient to transfer the plastic raw materials by means of closed transfer system. During feeding of plastic raw materials into mixing machine it is important to feed the raw materials completely. Vacuum conveyor provides complete transfer of raw material.

REFERENCE

- [1] Method of injection molding pvc products(henricus g. M. Loman, 43, aadorpweg, wierden 7641 ek, netherlands).
- [2] Dry solids continuous blending and conveyng apparatus(charles m. Gilman, gilman, conn., assignor to the gil man brothers company, gilman, conn., a corporation of connecticut)
- [3] Vacuum loader system(douglas james boring, franklin, pa.).
- [4] Production of plastic-filler mixtures(hans grigull, cologne, germany).
- [5] Apparatus for degassing and supplying plastic material to processing machines(dieter bettermann, cologne, fed. Rep. Of germany).
- [6] Wacuum-operated produce handling systems(bernard r. Tennes, charlotte; richard j. Wolthuis, haslett; clyde l. Burton, east lansing, all of mich.).
- [7] Apparatus for conveying granular plastic material(gerhard goth, benningen (de))
- [8] Pump fortransferring particulate material(joseph m. Klobucar, detroit, james l. Pakkala, livonia, mi (us); mazen haddad, warren, mi (us david j. Cole, canton, mi (us)).
- [9] effects of an electrstatic field in vacuum conveying of granular materials through inclined and vertical pipes(eldin wee chaunlimzang chi-hwawang) .



10.22214/IJRASET



45.98



IMPACT FACTOR:
7.129



IMPACT FACTOR:
7.429



INTERNATIONAL JOURNAL FOR RESEARCH

IN APPLIED SCIENCE & ENGINEERING TECHNOLOGY

Call : 08813907089  (24*7 Support on Whatsapp)