



iJRASET

International Journal For Research in
Applied Science and Engineering Technology



INTERNATIONAL JOURNAL FOR RESEARCH

IN APPLIED SCIENCE & ENGINEERING TECHNOLOGY

Volume: 7 Issue: IV Month of publication: April 2019

DOI: <https://doi.org/10.22214/ijraset.2019.4099>

www.ijraset.com

Call:  08813907089

E-mail ID: ijraset@gmail.com

Design & Development of an IoT based Firefighting Robot using Arduino

Vipul Agrawal¹, Anoop Kini²

^{1,2}Department of Computer Engineering, Thakur College of Engineering & Technology, Mumbai, India

Abstract — Increasing human population and technological development has led to an increase in fire accidents and hazards. Adverse conditions and physical limitations of the human being make fire extinguishing a challenging and demanding task. Fire extinguishing is a very risky task and it may involve loss of life. Robotics is the emerging solution to protect the surrounding and human lives. Fire extinguishing robot is a hardware model which can be used for extinguishing the fire during fire accidents. It can reduce the errors and limitations faced by the humans during the fire extinguishing task. Our designed robot can search the area, locate the fire and extinguish the fire before it rages out of control with minimum human intervention. The robot which we have proposed in this paper found its application in fire extinguishing operations during fire accidents which are hazardous and the possibility of the servicemen to enter the fire-prone area is very less

Keywords — Watermist, Fire Hazardous, Arduino, Robotics, Wireless Camera.

I. INTRODUCTION

The idea of integrated electronics in everyday objects is extremely attractive; Detecting fire and extinguishing it is a dangerous job that puts the life of a firefighter at risk. There are many fire accidents which firefighter had to lose their lives in the line of duty each year throughout the world. The research and development in the field of Artificial Intelligence have given rise to Robotics. The aim here is to design a Fire Fighting robot based on IOT. The robot will not only extinguish the fire but can even act as a path guider. The Robot should be able to find a fire before it rages out of control and must also reduce the risk of injury to victims. The Robot is based on Android application, used for controlling the robot and operating the camera mechanism. To have a proper and a broader view of the surrounding a wireless camera is mounted to continuously scan the surrounding. The robot is equipped with various sensors which continuously monitors to detect flame, human casualties temperature, humidity and extinguishes the fire if present with the help of a Watermist turbine

II. LITERATURE SURVEY

In today's era firefighting is a dangerous issue. Many authors are working on different techniques for firefighting:

^[1]**Author Ratnesh Malik et al.** have developed an approach towards fully autonomous firefighting robot to extinguish the fire. It implements the concept likes environmental sensing and awareness, proportional motor control. The robot processes information from its sensors and hardware elements. Ultraviolet, Infrared and visible light are used to detect the components of the environment.

^[2]**Author Kristi Kokasih et al.** has developed an intelligent firefighting tank robot. Tank robot is made from acrylic, plastic, aluminum, and iron. Robot components are two servo motors, two DC motors, ultrasonic sensor, compass sensors, flame detector, a thermal array sensor, a white detector (IR and phototransistor), sound activation circuit and microswitch sensor.

^[3]**Author Lakshay Arora et al.** has developed a Cell phone-controlled robot with fire detection sensors. It consists of a mobile phone which controls a robot by making a call to the mobile phone which is attached to the robot. During the call activation period, if any button is pressed on the phone, the tone corresponding to the button pressed is heard at the other end of the call that is placed on the robot. The robot perceives Dual-Tone Multiple-Frequency (DTMF) tone with the help of a phone mounted on the robot. The received code is processed by the microcontroller and then the robot performs actions accordingly.

^[4]**Author Anij Joseph John et al.** designed a low cost, robust and secure fire protection system for buildings. It sends an early alarm when the fire occurs and helps to reduce the fire damage. This system consists of a smoke detector and a temperature sensor whose outputs are connected to the controller. The system takes into account the density of smoke and thus the probability of false alarms can be avoided.

III. PROBLEM STATEMENT

Detecting fire and extinguishing it is a dangerous job that puts the life of a firefighter at risk. There are many fire accidents which firefighter had to lose their lives in the line of duty each year throughout the world. The research and development in the field of Artificial Intelligence have given rise to Robotics. The aim here is to design a Fire Fighting robot based on IOT. The robot will not only extinguish the fire but can even act as a path guider. The Robot should be able to find a fire before it rages

out of control and must also reduce the risk of injury to victims. The Robot is based on Android application, used for controlling the robot and receiving live feedback from the Wireless IP Camera installed on the robot.

IV. COMPONENT DETAILS

A. NodeMCU

It provides mobility to the robot via ESP8266 inbuilt in it.

B. Arduino UNO

The microcontroller is the heart of the robot which does the main function of detecting the fire and activating the watermist turbine to doze off the fire.

C. L298N Motor Driver

It is used to control the motion of a dc motor at two ends of the robot.

D. Flame sensor

This analog sensor is used to determine the presence of fire when wavelength of fire ranges between 790nm-1050nm.

E. DC Motors

It provides motion to the robot, assisted with the wheel connected to it

F. Wireless IP Camera

it is used to provide live feedback to the user to guide the robot.

V. PROPOSED WORK (BLASTOISE)

The application overcomes the problems in the current system in the following way:

The idea is providing a live update of the situation to the user via the wireless camera installed on the robot.

The robot can be controlled using a mobile device through which the user can control the robot's movements and focus on an area that is important.

The pump will get activated automatically by the robot as soon as flames or fire are detected.

VI. BLOCK DIAGRAM & CONNECTION DIAGRAM

In the existing system, there is no direct communication between the robot and the user. Resulting in the user being incapable of keeping a track on the activities of the robot. At the same time absence of artificial intelligence can also result in the robot's incapability to detect extensively fire-prone areas. Because of that, we are providing a feature of live feedback from the robot about its surrounding that it will capture and relay back to the user via the wireless camera. Fig.1 represents the Block Diagram of the Fire Fighting Robot. It portrays how the various components of the robot are interconnected to each other. The three Flame Sensors & Watermist turbine along with the power supply is connected Arduino UNO, which in turn is also responsible to provide power to the other components. The NodeMCU, which is the major component for mobility of the robot is

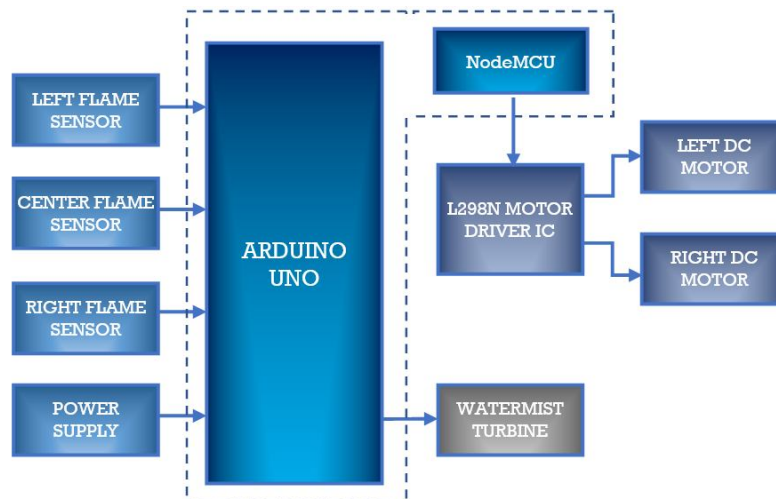

Fig. 1 Block Diagram of BLASTOISE

interconnected to the left & right DC motors via an L298N Driver Motor.

Fig.2 sketches a graphical representation of the hardware connection along with the circuit connection which is required for the movement purpose of the robot using NodeMCU. Whereas Fig. 3 depicts a graphical representation of the hardware connections with the circuit connection among the different components such as the Flame Sensors, Arduino UNO and the Watermist Turbine.

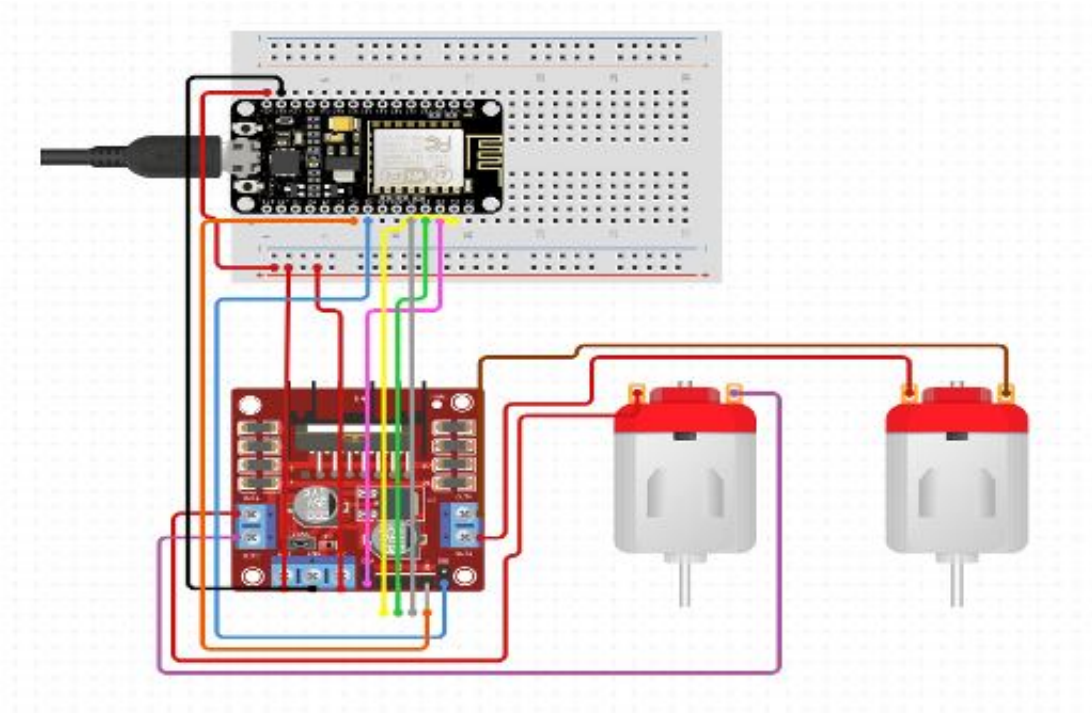

Fig. 2 NodeMCU, L298N Motor Driver & DC Motor Connection

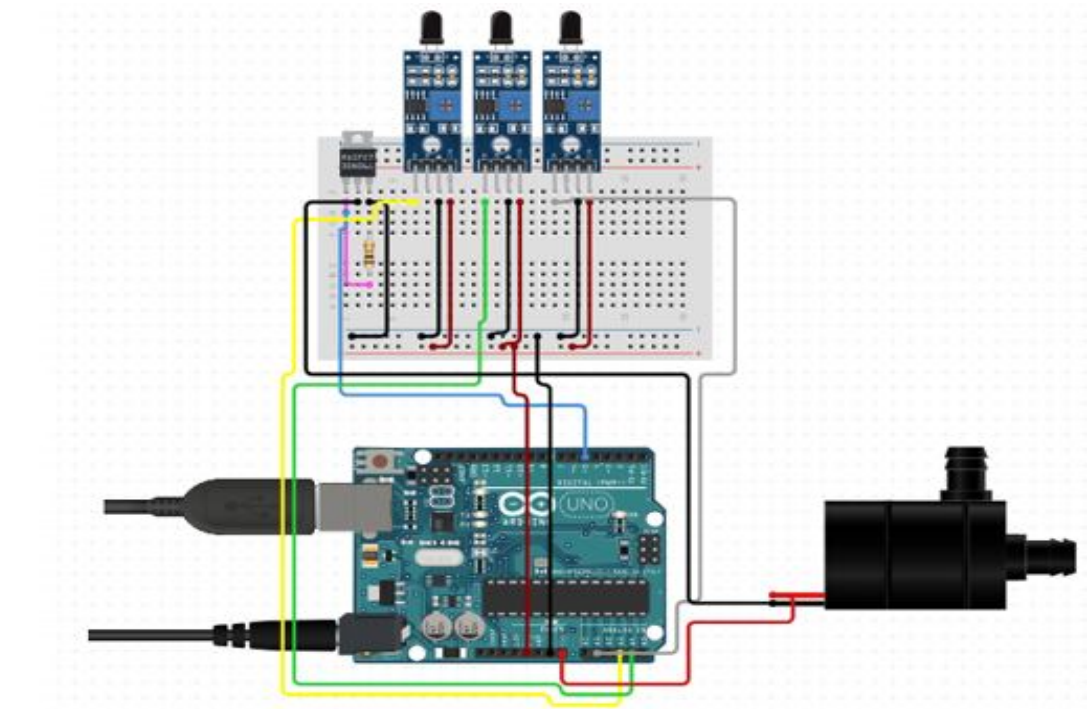

Fig. 3 Arduino UNO, three Flame Sensors & Water Pump Connection

VII. CONCLUSION

The venture of the robot is a battle against flames. The main objective was to build up a framework to identify and quench the fire before the fire expands and create any hazardous situation. The project utilizes Arduino UNO & NodeMCU (i.e. IOT) and the watermist turbines along with a flame sensor to detect fire around it. The mobility of the robot is through an android application which makes use of a private IP address to connect to the robot. Among the progressions that can be made are giving robot insurance by utilizing non-combustible materials, expanding the quality & quantity of sensors for recognizing hindrances and expanding the nature of the batteries operated for longer robot life. In our model, the robot was accompanied by a Watermist Turbine. However, there are numerous options in such a manner.

Following are the screenshots of our firefighting robot (BLASTOISE) & the Mobile Application User Interface to move the vehicle:

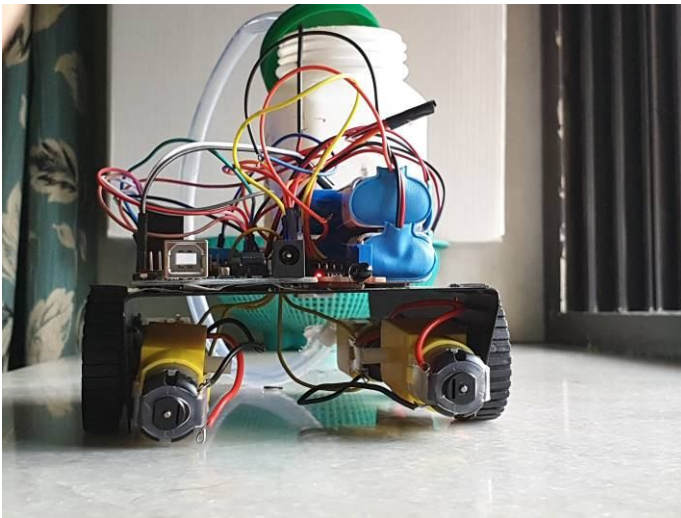

Fig. 4 Front view BLASTOISE

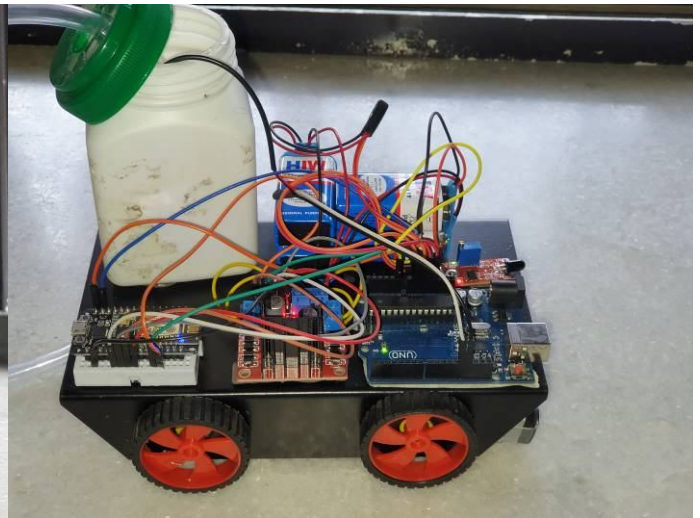

Fig.5 Upper View of BLASTOISE

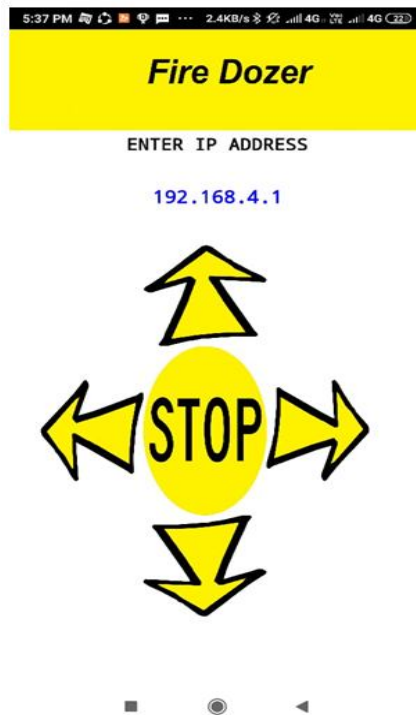

Fig. 6 User Interface



With the assistance of the above-portrayed robot, it very well may be presumed that a robot can be utilized instead of people, in this manner diminishing the danger of the life of a fireman. It tends to be utilized in our labs, homes, workplaces, parking garages, grocery stores, shops, Nuclear Plants and so on. They give incredible effectiveness and can quench the flame before it winds up wild and can be a risk to life.

VIII. FUTURE SCOPE

The project is expected to be deployed on a global scale. This project has been motivated by the desire to design a system that can detect fires and try to extinguish at a smaller scale. In the present condition, it can extinguish fire only as a prototype and not an actual fire in a location. A practical autonomous fire-fighting system must include a collection of robots that will work together to doze away a building under fire. Furthermore, a thermal sensing camera that can detect human beings once the fire quenched away can be used to protect the life of human beings trapped inside the building. Nowadays, compressed liquid Nitrogen balls are available that have a faster and cleaner effect in dozing off the fire. Such ball can also be used in the robot.

ACKNOWLEDGEMENT

We owe my deep gratitude to our project guide, Mrs. Vaishali Nirgude, Assistant Professor, Thakur College of Engineering & Technology who took a keen interest in our project work and guided us all along. She was always there whenever we needed any necessary information for developing a good system. We would not forget to mention about her encouragement and moreover for their timely support and guidance until the completion of our project work

REFERENCES

- [1] Ratnesh Malik, "Fire Fighting Robot : An Approach" , Indian Streams Research Journal Vol.2,Issue.II/March; 12pp.1-4.
- [2] Kristi Kosasih, E. Merry Sartika, M. Jimmy Hasugian, danMuliady, "The Intelligent Fire Fighting Tank Robot", Electrical Engineering Journal Vol. 1, No. 1, October 2010.
- [3] Lakshay Arora, Prof.AmolJoglekar, "Cell Phone Controlled Robot with Fire Detection Sensors", (IJCSIT) International Journal of Computer Science and Information Technologies, Vol. 6 (3) , 2015, 2954-2958.
- [4] Anij Joseph John, Ashik K, Avinash Vishnu KS, Fahmi P,Henna P, AUTOMATIC FIRE EXTINGUISHING ROBOTIC VEHICLE, International Journal of Scientific & Engineering Research, Volume 7, Issue 4, April-2016.
- [5] Taiser T.T. Brrros, Walter Fetter Lages, " Development of Fire fighting robot for educational competitions", RiE 2012, Prague
- [6] Chattunyakit S.Kondo T. and NilkhamhangI. (2013),"Development of Robotic Platform for swarm Robots in Fire Detection Application", Kasetsart Journal Natural Science,47,pp.967-976
- [7] Tan,C.F.,S.S.S. Ranjith, V.K. Kher and H.F.Kong,2013."Up-Scaling and Op-timization of Fire Fighting Ground Vehicle Track System". Applied Me -chanics and Materials,315:236-240.
- [8] H. P. Singh, Akanshu Mahajan, N. Sukavanam, VeenaBudhraj, "Control Of An Autonomous Industrial Fire Fighting Mobile Robot", DU Journal of Undergraduate Research and Innovation.
- [9] W. Budiharto, Membuat Robot Cerdas, Jakarta: Gramedia, 2006.
- [10] Arpit Sharma, ReeteshVerma, Saurabh Gupta and Sukhdeep Kaur Bhatia, "Android Phone Controlled Robot Using Bluetooth", International Journal of Electronic and Electrical Engineering.ISSN 0974-2174, Volume 7, Number 5 (2014), pp. 443-448
- [11] Phyoo Wai Aung, Wut Yi Win, "Remote Controlled Fire Fighting Robot", International Journal of Scientific Engineering and Technology Research Volume.03, IssueNo.24, September-2014
- [12] Poonam Sonsale, RutikaGawas, Siddhi Pise, Anuj Kaldate , "Intelligent Fire Extinguisher System",IOSR Journal of Computer Engineering (IOSR-JCE) e-ISSN: 2278-0661, p- ISSN: 2278-8727Volume 16, Issue 1, Ver. VIII (Feb. 2014), PP 59-61 www.iosrjournals.org
- [13] <https://www.crisis-response.com/comment/blogpost.php?post=221>



10.22214/IJRASET



45.98



IMPACT FACTOR:
7.129



IMPACT FACTOR:
7.429



INTERNATIONAL JOURNAL FOR RESEARCH

IN APPLIED SCIENCE & ENGINEERING TECHNOLOGY

Call : 08813907089  (24*7 Support on Whatsapp)