



# **iJRASET**

International Journal For Research in  
Applied Science and Engineering Technology



---

# **INTERNATIONAL JOURNAL FOR RESEARCH**

IN APPLIED SCIENCE & ENGINEERING TECHNOLOGY

---

**Volume: 7      Issue: IV      Month of publication: April 2019**

**DOI: <https://doi.org/10.22214/ijraset.2019.4084>**

**[www.ijraset.com](http://www.ijraset.com)**

**Call:  08813907089**

**E-mail ID: [ijraset@gmail.com](mailto:ijraset@gmail.com)**

# Inverter Fed DC Motor Speed Control for Open Loop and Closed Loop Control

Ezhilarasi. A<sup>1</sup>, Rajalakshmi. P<sup>2</sup>

<sup>1,2</sup>Sri Chandrasekharendra Saraswathi Viawa Maha Vidhyalaya, Enathur, Kancheepuram-631561,TN,India

**Abstract:** This paper introduces speed management of one by one excited DC motor by victimization DC-DC Buck convertor fed from DC supply. There are four different parts of control of DC motors used in this paper. The DC-DC Buck convertor firing circuit gets a pulse from controller then by supply a variable controlled voltage to the coil of the DC motor, the specified speed of the motor can be achieved. Digital PWM type controller is used to provide control of current and control of speed of the DC motor. These controllers provide a fast control. The current and speed management is intended so as to urge stable and high speed control of DC motor. Finally simulation results for the planned system ar displayed that ar in step with the expected results.

**Index Terms** – DC motor, speed, inverter, open loop, close loop.

## I. INTRODUCTION

Semiconductor converters may be grouped into three main categories, According to their functions.

- Transfer of power from an alternating current (ac) supply to direct current (dc) form. This type of convertor is typically known as a rectifier.
- Transfer of power from a direct current supply to alternating current form. This type of convertor is typically known as AN electrical converter.
- Transfer of power from an ac supply directly into an ac load of different frequency. This type of convertor is termed a cyclo-convertor or a matrix convertor.
- Transfer of power from a direct current supply directly into a direct current load of different voltage level. This type of convertor is termed a chopper convertor or a switch-mode convertor.

## II. DC –DC CHOPPER

A chopper is a static power electronic device that converts fixed dc input voltage to a variable dc output voltage. A Chopper may be considered as dc equivalent of an ac transformer since they behave in an identical manner. Choppers ar currently being employed everywhere the globe for public transit systems. These are utilized in tram cars, marine hoist, forklift trucks and mine haulers. The future electrical cars ar doubtless to use choppers for his or her speed management and braking. Chopper systems provide swish management, high efficiency, faster response and regeneration facility.

As mentioned higher than, a chopper is dc equivalent to an ac transformer, have continuously variable turn’s ratio. Like a electrical device, a chopper can be used to step down or step up the fixed dc input voltage. The step down version of chopper is also called dc-dc step down chopper is used to control the armature voltage of the dc motor for speed control applications.

## III. PULSE GENERATION CIRCUIT

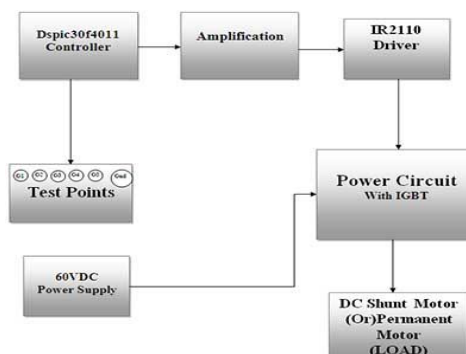

#### IV. BLOCK DIAGRAM

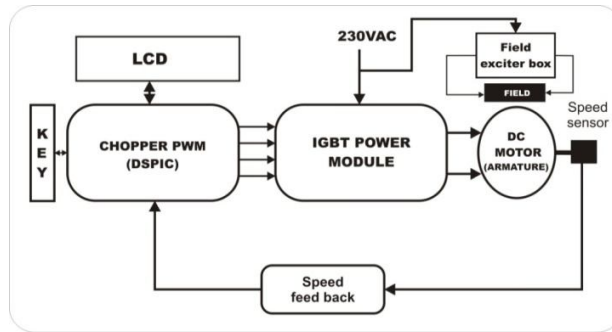

In open loop control, the control action from the controller is independent of the "process output" (or In

##### A. Open Loop Control

open loop management, the control action from the controller is independent of the "process output" (or "controlled process variable"). A good example of this is a central heating boiler controlled only by a timer, so that heat is applied for a constant time, regardless of the temperature of the building. The management action is that the switch on/off of the boiler, but the controlled variable should be the building temperature, but is not as this is open-loop control of the boiler, that doesn't provide closed-loop management of the temperature.

##### B. Closed Loop Control

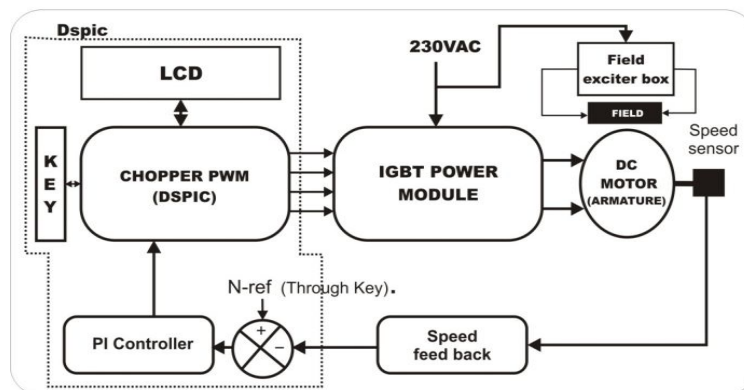

The closed-loop system means that the output of the system depends on their input. The system has one or a lot of feedback loops between its output and input. The closed loop style in such the simplest way that they mechanically give the specified output by examination it with the particular input. The closed loop generates the error signal that is that the distinction between the input and output.

#### V. IGBT POWER MODULE (VOLTAGE SOURCE INVERTER):

This module is designed by using IGBT based smart power module(SPM) for AC/DC Motor control application. This power module can be used for AC, DC, BLDC, PMSM Motor application by proper external PWM controller interfacing (like Dspic, FPGA & DSP). This module consists of,

##### A. IGBT

- 1) One Number of SPM-Smart Power Module (Model FSBB20CH60B) rating @ 600V, 20A based voltage source inverter power circuit.
- 2) -IGBT is fixed with suitable heat sink and snubber circuit for protection..



*B. Diode Rectifier*

- 1) One number of diode rectifier (600V @35A) is provided to convert AC voltage to DC bus voltage.
- 2) DC Capacitor is provided (Center point type) at diode rectifier output side for filter.
- 3) Analogue DC voltmeter is provided to measure DC Bus Voltage.

*C. PWM Isolator*

- 1) Six Number of PWM Isolator IC (6N137) is used to isolate All the six PWM signals input.
- 2) One number of +15V@1amp fixed dc power supply is provided for PWM Isolator input side for power excitation.
- 3) One number of +5V@1amp fixed dc power supply is provided for PWM Isolator Output side power excitation.

*D. PWM Driver*

- 1) Built in IGBT Gate Driver is provided in SPM for IGBT Gate signal amplification.

*E. Protection Circuit*

- 1) One number of automatic trip circuit is provided for O/C protection.
- 2) LED is provided for trip status indication.
- 3) Reset switch is provided for TRIP RESET.

*F. Connectors*

- 1) One number of 34 pin FRC Connector is provided for PWM input signal input and feedback.
- 2) Banana connectors are provided for AC input.
- 3) Banana connectors are provided for 3 phase output.
- 4) Test points are provided for PWM signal and Current wave form measurements.
- 5) MCB is provided at input side for Input supply ON/OFF.

*G. Digital PWM Controller*

This PWM controller is designed based on Dspic30f4011 controller chip specially designed for Power Electronics & Motor control applications from "MICROCHIP" company and this controller can be used to generate PWM Signals for SCR, IGBT based power sensor/Speed sensor(Proximity)Interface.

- 1) PWM increment & decrement key.
- 2) Reset switch & LED's for Sensor status.
- 3) 20 X 4 LCD screen.
- 4) PWM outputs are terminated by 34 pin FRC Connector

Electronics application like DC-AC Inverter ,DC-DC Chopper & SCR converter based AC/DC/BLDC Switched Reluctance Motor (SRM) control application. PWM output of this controller can be directly interfaced with Power Module through External cable connection.

## VI. FEATURES

- A. Includes High-Performance Microchip dsPIC30F4011 Microcontroller with 48kb Internal Flash Program Memory.
- B. 6 Numbers of PWM Outputs up to 15KHZ of switching frequency.
- C. RS232 Connection with MAX232.
- D. Internal EEPROM.
- E. Five 16-bit Timers.
- F. Power, Programming and Test LED's.
- G. 2MB PROM & 24 Mhz clock speed.
- H. 6 Numbers of ADC input.
- I. QEP Sensor /Hall

### VII. OUTPUT WAVEFORMS

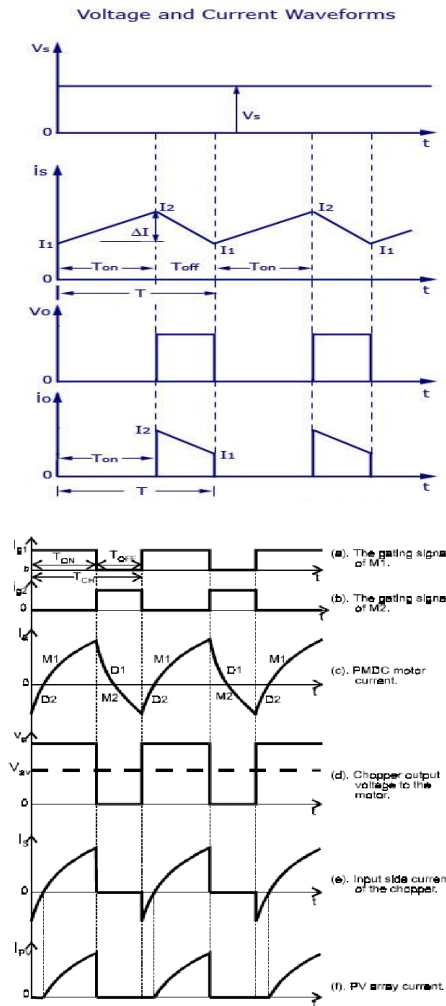

### VIII. CONCLUSION

This paper introduces speed control of separately excited DC motor by using DC-DC inverter fed from DC source. There are four different parts of control of DC motors used in this paper. The DC-DC inverter firing circuit gets a pulse from controller and then by supplying a variable controlled voltage to the armature of the DC motor, the desired speed of the motor can be achieved. Digital PWM type controller is used to provide control of current and control of speed of the DC motor. These controllers provide a fast control.

The current and speed management is meant so as to urge stable and high speed control of DC motor. Finally simulation results for the proposed system are displayed which are consistent with the expected results.

### REFERENCES

- [1] Khoei and Hadidi, "Microprocessor Based Closed-Loop Speed Control System for DC Motor Using Power Mosfet," 3rd IEEE International Conference on Electronics, Circuits and Systems, ICECS, Oct. 1996.
- [2] Y. S. E. Ali, S. B. M. Noor, S. M. Bashi and M. K. Hassan, "Microcontroller Performance for DC Motor Speed control system," National power and energy conference, Malaysia, Dec. 2003.
- [3] Mechi, S. Funabiki, "Step-up/down voltage PWM ac-dc converter with one switching device" in IEE Proc., 1993, pp. 35-43.
- [4] R. Prasad, P. D. Iogas, and S. Manias, "A Novel Passive Wave Shaping Method For Single-Phase Diode Rectifiers," IEEE Transactions on Industrial Electronics, Vol. 37, No. 6, pp 521-529, 1990.
- [5] S. S. Shokralla, "A Simplified Approach For Closed-Loop Speed Control of a DC Motor Using AC To DC Converter," Alexandria Engineering Journal, Vol. 36, No. 2, March 1997.



10.22214/IJRASET



45.98



IMPACT FACTOR:  
7.129



IMPACT FACTOR:  
7.429



# INTERNATIONAL JOURNAL FOR RESEARCH

IN APPLIED SCIENCE & ENGINEERING TECHNOLOGY

Call : 08813907089  (24\*7 Support on Whatsapp)