



# IJRASET

International Journal For Research in  
Applied Science and Engineering Technology



---

# INTERNATIONAL JOURNAL FOR RESEARCH

IN APPLIED SCIENCE & ENGINEERING TECHNOLOGY

---

**Volume: 7      Issue: IV      Month of publication: April 2019**

**DOI: <https://doi.org/10.22214/ijraset.2019.4097>**

**[www.ijraset.com](http://www.ijraset.com)**

**Call:  08813907089**

**E-mail ID: [ijraset@gmail.com](mailto:ijraset@gmail.com)**

# Smart Self Recovery

Shubham Yadav<sup>1</sup>, Mr. Brijesh kumar Dubey<sup>2</sup>, Mr. Devendra kumar Pandey<sup>3</sup>

<sup>1</sup>Department OF Electrical and Electronics Engineering, PSIT, Kanpur, Uttar Pradesh

<sup>2</sup>Assistant Professor Department of Electrical AND Electronics Engineering PSIT, Kanpur

<sup>3</sup>Assistant Professor Department of Electrical AND Electronics Engineering PSIT, Kanpur

**Abstract:** Electric distribution utilities are paying more and more attention towards enhancement of end-user supply reliability and power quality. “Self-heal” nature of distribution network is gaining interest in the industry. With deployment of distribution automation applications, they can not only achieve these performance goals but also improve situational awareness, and reduce the financial penalties they incur due to system outages. Fault Location, Isolation and Service Restoration (FLISR) is one of the key distribution automation application, which can significantly reduce outage time to the end customers. At the same time, standardized automation system based on IEC 61850 is proliferating in the market. This paper proposes a fast FLISR algorithm using IEC 61850 based Generic Object Oriented Substation Event (GOOSE) technology. The challenges and possible solutions while commercially deploying such smart applications are discussed in further detail.

## I. INTRODUCTION

Power distribution system is an important part of electric power system in order to supply reliable, efficient and safe power to the consumers [1], [2]. High penetration of distributed energy resources and implementation of performance regulations in distribution system have forced utilities to improve the reliability of their network, and reduce the financial penalties incurred due to system outages [3]. This requires the implementation of various smart strategic distribution automation applications in the distribution network. Fault Location, Isolation, and Service Restoration (FLISR) application (also known as Fault Detection, Isolation and Restoration, FDIR) is a key building block for any utility’s smart distribution grid solution [4]. FLISR enables utilities to significantly improve their distribution network reliability and gain economic benefits [5], [6]. IEC 61850 specifies communication system for power utility automation [7]. Various challenges and possible solutions are proposed in Section-IV. Finally, Section-V concludes the work.

## II. SMART DISTRIBUTION NETWORKS

### A. How Smart Recovery can Reduce Outage Time?

In case of fault on a distribution network, substation feeder protection normally shuts-down power on the entire feeder, which causes disruption in the service to many end-user customers, including industrial, hospitals, commercials and residential. Fig. 1 illustrates a typical fault scenario and outage time comparison with and without FLISR implementation. It can be observed from the figure that with fast FLISR action (within a minute), the total outage time can be reduced to approx. 3-4 hours per outage. This way, FLISR or circuit reconfiguration schemes, can greatly enhance the distribution grid reliability by quickly restoring power to the as many customers as possible. Section-II of the paper discusses advantages of FLISR deployment with an example and compares various FLISR approaches. Further, D-FLISR solution using peer-to-peer IEC 61850 GOOSE communication is proposed in Section-III.

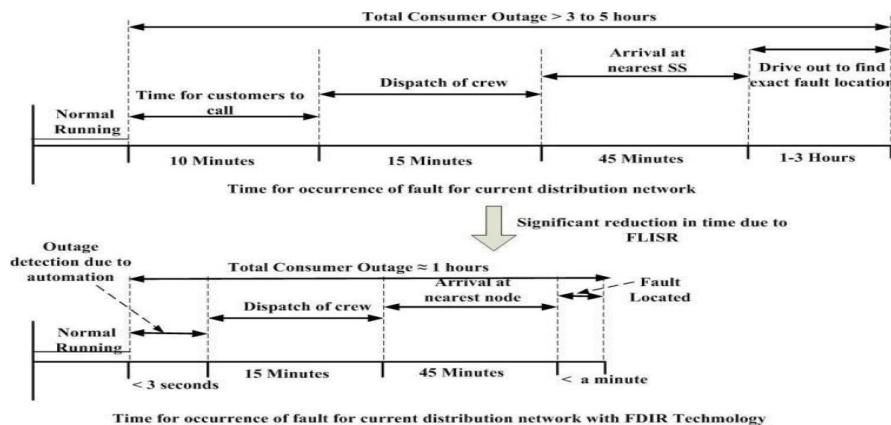

Fig. 1 Example on outage time reduction using FLISR deployment

As per the regulatory standard guidelines, many distribution utilities are measured based on power supply reliability indices to quantify qualitatively how well they are serving their customers, and may be subjected to regulatory penalties if the regulators feel their performance is not as good as it should be. There are several different measurement indices that are used to gauge utility reliability effectiveness such as: SAIDI (System Average Interruption Duration Index) measuring the average number of minutes of interruptions that a customer would experience; SAIFI (System Average Interruption Frequency Index) shows the average number of interruptions that a customer would experience; CAIDI – (Customer Average Interruption Duration Index) calculates the average outage duration that any given customer would experience; CML - Customer Minutes Lost per average 100 customers; CI - Customer Interruptions per average 100 customers; etc.

### B. FLISR Process Steps

Following are the various steps of a typical FLISR system:

- 1) *Fault location (followed by fault detection):* Fault location algorithm is the first step for the FLISR, which is triggered by the substation protection devices (Intelligent Electronic Device, IED or recloser controller). After faulty feeder tripping, the faulty section on the tripped feeder needs to be located. A faulty section of the feeder is referred as a portion of feeder between two switches/reclosers.
- 2) *Fault isolation:* After identifying the faulty feeder section, both sides of the fault need to be isolated using switches/reclosers.
- 3) *Capability Estimation:* After isolation and before restoration, a capability estimation need to be carried out to determine if service restoration from a healthy feeder is possible.
- 4) *Service Restoration:* From capability estimation, it is determined whether complete or partial load of the faulty feeder can be transfer to healthy feeder. Accordingly, the service restoration process closes tie-switch and corresponding feeder switches (which can feed healthy portion of the faulty feeder).

### C. FLISR Architectures

This subsection discusses the various architectures of FLISR deployment:

- 1) Centralized FLISR (C-FLISR)
- 2) De-Centralized FLISR (DC-FLISR)
- 3) Distributed FLISR (D-FLISR)

Centralized approach may be implemented as one of the applications of the Distribution Management System (DMS) or Distribution-SCADA. Feeder optimization can be achieved at the highest possible level, with more complex switching logics, and effective load distribution.

However, each switch controller needs to communicate with the control center directly, and this may require high bandwidth communication network, as well as accurate load model information. The response time of the complete automation system may be comparatively high.

On the other hand, DC-FLISR system is deployed at the substation level using a single or a redundant automation device installed in each substation. The remote I/O modules installed at each switch/recloser locations need to be connected to the distribution substation automation device over communication network. As compared to the C-FLISR, the DC-FLISR system is faster with lower bandwidth requirements.

The achieved solution may not be the best optimized one, but it is easy and less expensive to deploy. The distributed approach (D-FLISR) uses controlled devices at each switch/recloser locations, and these devices communicate among each other to determine where the fault has occurred and to determine the appropriate switching actions necessary for the restoration. The IEC 61850 GOOSE based peer-to-peer communication technology is a good fit for such applications. As the intelligent devices (controllers) are distributed, reliability of the scheme higher, however, this requires controller (instead of remote I/O units) at each switch location.

This paper focuses on the D-FLISR scheme based on the IEC 61850 GOOSE, as proposed in the following section.

## III. PROPOSED D-FLISR ALGORITHM USING IEC61850 GOOSE MESSAGES

### A. Typical Distribution System Loop and Control Structure

Fig. 2 shows a typical distribution system with a loop configuration where feeders from two substations can be connected through a normally open tie switch. Each substation contains a breaker/recloser which is controlled by the substation protection Intelligent Electrical Device (IED) (operates substation breaker/recloser in case of fault on the feeder).

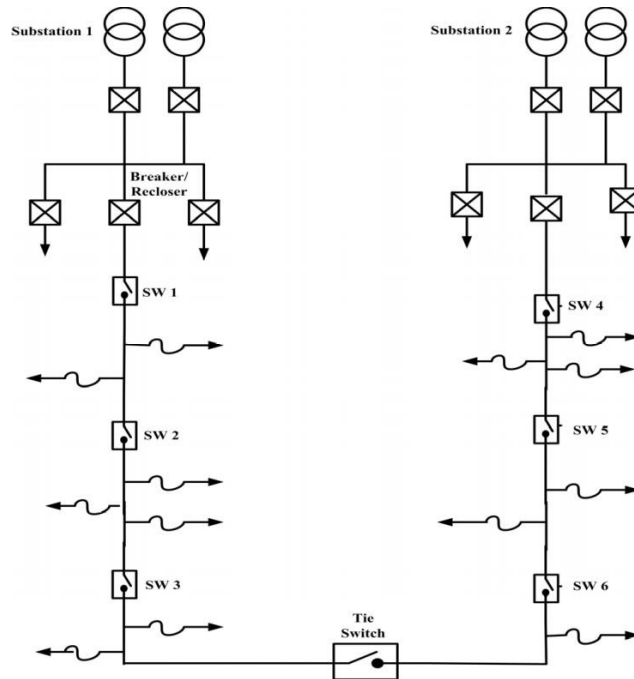

Fig. 2 Different architectures of FLISR

Multiple switches/reclosers are installed over each feeder. These switches/reclosers are also equipped with a local control which has a communication capability. Message/Information exchange among the recloser controllers in D-FDIR would be through high speed, peer-to-peer IEC 61850 GOOSE communication. The D-FLISR is performed in each switch/recloser controller, and not a single controller takes the entire FLISR sequence, as a Master.

**B. IEC 61850 GOOSE Messages for the Proposed FLISR**

Following is the list of GOOSE message types required for the proposed D-FLISR:

Table - I GOOSE message types

GOOSE message types	Description
LO	Lock Out message
FD	Fault Detection message
TT	Transfer Trip message
FIA	Fault Isolation Acknowledgement
FIC	Fault Isolation Complete confirmation
FNC	Fault Not Isolated
SM	Sufficient Margin available
NSM	No Sufficient Margin
RC	Restoration Complete
RT	Restoration Terminated

In addition, each controller needs to log the maximum amount of load that goes through the respective switch/controller for settable (short and long) amount of time. Load for this algorithm has two quantities: 1) power and 2) current. Power for load capability calculation, and current is also needed for segment loading capacity and make and carry capacity of a switch/recloser. Therefore, the analog GOOSE would require for the following items:



- 1) Pre-fault load current and power
- 2) Transformer power capacity
- 3) Feeder section current capacity
- 4) Recloser current load margin
- 5) Recloser load current at the end of D-FLISR process

C. Algorithm Requirements / Assumptions

- 1) The recloser controllers have battery backup power, sufficient to complete the D-FLISR algorithm.
- 2) The transformer and feeder capacity margins are programmed into the recloser controllers prior to algorithm operation.

D. Fault Location and Isolation Algorithm

Fig. 3 shows the fault location and isolation algorithm. The fault (section) location process begins after an upstream substation breaker or recloser is operated (by a digital relay or a controller) on the fault current, and subsequently broadcasts a **LO** GOOSE message.

If the Lock-Out recloser/breaker is not immediately adjacent to the fault, there will be switches downstream that sense the fault and lose power after lock out. These switch controllers will multicast **FD** GOOSE message upon reception of the **LO** GOOSE message and loss of power. If substation breaker/recloser does not receive any **FD** GOOSE message (but still receive heartbeat/healthy communication GOOSE messages), in this case fault is located immediately after the substation breaker and before the first downstream switch.

Hence, substation relay also sends **TT** message to immediate Downstream Isolation Switch (DIS) (which identifies immediate downstream switch from faulty section), and opens the switch, upon reception of acknowledgement (FIA) message from downstream switch, the **FIC** message is sent by upstream intelligent device (which can also be a substation feeder relay or a controller).

The switch controller that is immediately upstream and adjacent to the fault is the Upstream Isolation Switch (UIS); this is determined by looking at all the recloser/switch IDs that were broadcast along with the **FD** messages. The UIS also sends **TT** message to DIS. In case an upstream and/or downstream switch is stuck (due to mechanical failure), **FNC** message is sent by UIS and/or DIS, and other upstream and/or downstream will be re-assigned as UIS and/or DIS respectively.

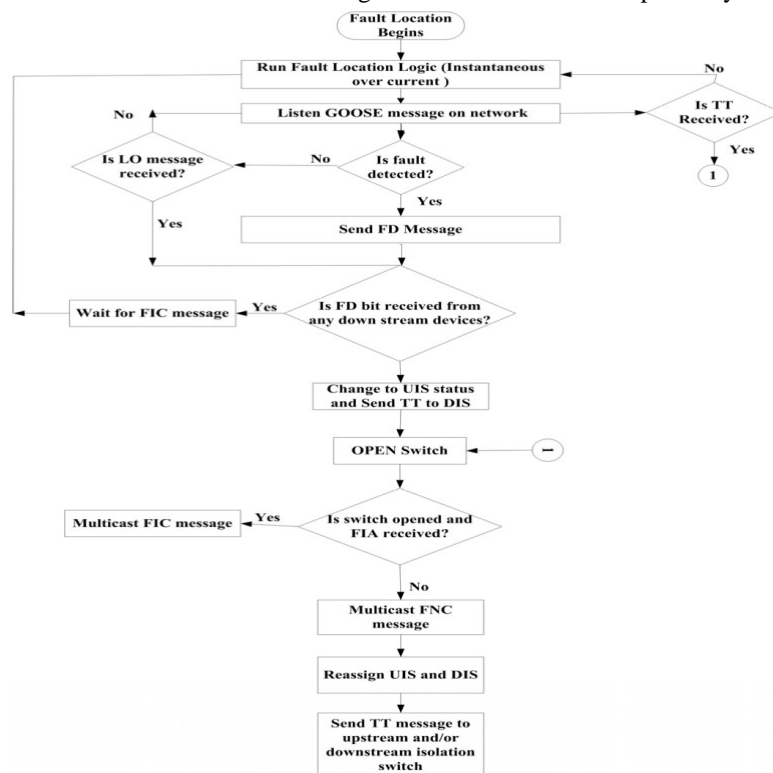

Fig. 3 Fault location and isolation algorithm

**E. System Restoration Algorithm**

In order for system restoration to occur, two conditions must be met:

- 1) There should be sufficient power capacity from the alternative substation.
- 2) There should be sufficient switch “make and carry” capacity and feeder conductor capacity on both at the healthy section and at the de-energized section.

The controllers on the faulty feeder need to communicate to the healthy feeder substation controller to determine if that substation can support the extra amount of load. Also it is important to check that each segment of the loop (with exception of dead segments) can handle addition load and the tie can have enough make and carry capacity.

Fig. 4 shows the system restoration algorithm, which is initiated upon reception of **FIC** message. Each switch controllers on healthy feeders calculates Current Capacity Margin (CCM) using (1), and transmits CCM messages with the respective GOOSE IDs to all downstream switches on faulty feeder.

**F.  $CCM = \text{Feeder Capacity Limit} - \text{pre-fault load current}$  (1)**

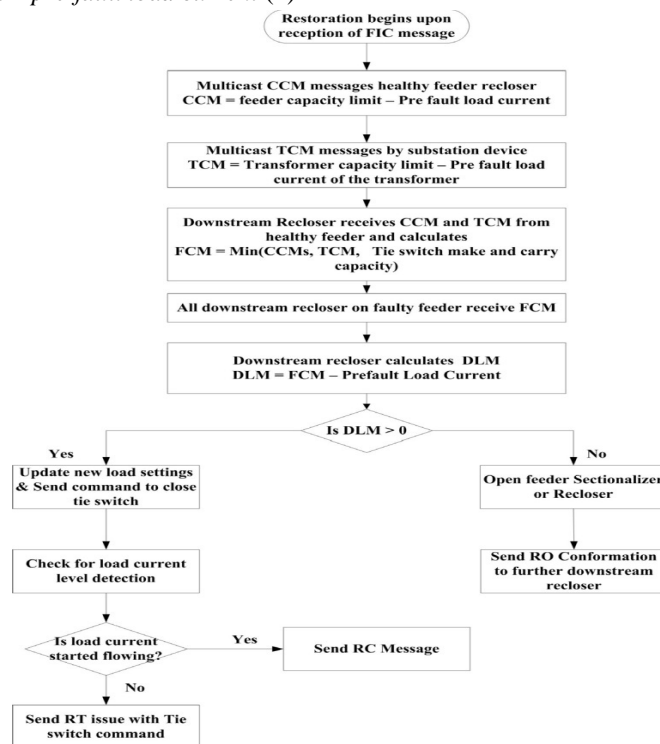

Fig. 4. System restoration algorithm

At the same time, substation relay/controller populates Transformer Capacity Margin (TCM), and transmits TCM message to all downstream switches:

**G.  $TCM = \text{Transformer Capacity Limit} - \text{pre-fault load current}$  (2)**

Upon reception of CCM messages and TCM message, each of the downstream switch controllers would calculate Feeder Capacity Margin (FCM) using (3), and Downstream Load Margin (DLM) using (4):

$$FCM = \text{Min} (CCMs, TCM, \text{Tie-switch make \& \dots carry capacity}) \quad (3)$$

$$DLM = FCM - \text{pre-fault load current \dots on reverse direction} \quad (4)$$

Each downstream recloser controller on the faulty feeder checks if DLM is positive value (load margin is sufficient to the respective feeder section), then multicast Sufficient Margin available (**SM**) message, or else the switch controller opens the switch and then send No Sufficient Margin available (**NSM**) message. The tie-switch controller, upon reception of **SM** and **NSM** messages, closes the tie-switch.

#### IV. CHALLENGES & POSSIBLE SOLUTIONS

##### A. Communication Technologies for D-FLISR

Success of FLSIR highly depends on the reliable communication technology used for information/messages exchange between the intelligence devices located along the feeder. Moreover, Power Line Communication (PLC) may not be appropriate for FLISR application, as the feeder line section would be isolated. In the recent report on National Institute of Standard and Technology (NIST) framework and roadmap for Smart Grid interoperability standards [8], several wired and wireless Communication technologies are identified for various smart grid applications [9]. Potential wireless technologies for the successful implementation of the FLSIR are briefly discussed in following Table-II.

Table- II Potential wireless technologies

Wireless Technology	Data Rate	Approx. Coverage
Wireless LAN	1-54Mbps	100m (repeater may increase the coverage)
WiMAX	70Mbps	48Km
Cellular	60-240Kbps	10-50km
Spread spectrum radio (900 MHz)	106Kbps	Up to 50km with repeater

Implementation of wireless technology offers many advantages over wired, e.g. low installation cost, mobility, remote location coverage, rapid installation, etc. However, each technology has certain challenges/limitations. Some of the common concerns for wireless technologies are: 1) wireless technologies operating in unlicensed frequency spectrum are more susceptible to interference/noise effects; 2) wireless technologies with licensed spectrum has less interference, but they are costly solution comparatively; 3) security of wireless media is inherently less. Further discussion on these technologies can be obtained from [10], [11].

##### B. Contingency Considerations

- 1) *Communication link failure*: Distribution automation applications are mainly achieved using the seamless communication link among the installed intelligent devices. However, an effective algorithm has to consider discrepancy in communication links. The proposed FLISR relies on multicasting of IEC 61850 GOOSE messages. The GOOSE technology offers heartbeat/retransmission mechanism, to check the communication association with other end devices. In case if GOOSE messages are not received after elapse of wait time from a particular controller, other switch controller would assume the failure of link or the device. In this case, algorithm will eliminate that switch from FLISR sequence. This would mean, that switch will not be given any control actions. At the same time, it is proposed to notify failure of the communication to the substation Human Machine Interface (HMI). In case if GOOSE message from multiple controllers are not received, the controller should connect with substation HMI, and declare FLISR termination. Dual communication path or technology per device can further enhance the communication link reliability, with additional cost of redundant communication network.
- 2) *Distributed - switch controller failure*: Most of the digital controllers has self-check feature. In case of any component is identified as failed, the controller will communicate to other peers about its failure. Consequently, that switch (with failure controller) will be eliminated from the FLISR sequence.
- 3) *Mechanical failure of a switch or a tie-switch*: The proposed algorithm already provides solution for this contingency, by re-assigning UIS and/or DIS, to take actions by upstream switch controller of UIS in case UIS failed, and downstream of the DIS if DIS failed.

##### C. Limitations of the Proposed Algorithm – Future Scope

- 1) *Complex distribution network configuration, and voltage regulation constraints*: The proposed algorithm is applicable to looped distribution network. There may be more complex distribution network configurations, e.g. multi-loop distribution network. The proposed algorithm does not cover multi-loop at once. To address this issue, either multi-loop network should be divided into multiple single loop logics or Centralized FDIR (C-FDIR) which is discussed before the proposed algorithm, is

deployed to cover the entire distribution network. The restoration may be restraint by voltage regulation constraints. These restraints are not considered in the current algorithm, and will be addressed in the future.

- 2) *Immediate Second fault*: It is possible that a second fault occurred before FLISR completes its sequence. Currently, algorithm cannot address this issue. It is proposed here that, if a second fault detection (**FD**) message is received from faulty feeder, before restoration process complete confirmation (**RC**), the restoration process should be terminated, and it should be communicated to substation HMI. In case of a second fault on healthy feeder during an FLISR process, secondary FLISR will get triggered only after the completion of the ongoing FLISR; this will have to be implemented in a queuing process.
- 3) *Fault persist after restoration*: It is possible that a fault persists even after a restoration process. This could possibly happen if two faults occurred simultaneously on two different sections of a same feeder. It is possible to initiate the FLISR algorithm a second time in this case or terminate FLISR and trip the entire feeder, based upon utility practice.
- 4) *Blind spots*: The initial version of the algorithm cannot detect blind spots, which are faults located between a recloser controller and its current transformer. For this feature, the fault detection device has to be installed on both sides of switch/reclosure or a directionality feature would require. This option could be expensive. Hence, it may happen that fault location may not provide exact faulty feeder section, and hence fault persists after restoration. Previous item discusses proposed solution in this situation.

#### V. CONCLUSION

This paper proposes a fast D-FLISR algorithm based on IEC 61850 GOOSE messaging to reduce service outage time. The complete details of fault location, isolation, and service restoration process are discussed with identified different types of IEC 61850 GOOSE messages. The proposed restoration algorithm also considers various capability limits of the feeder, switch and transformer. Furthermore, the wireless based communication technologies are discussed to achieve the proposed algorithm with low cost. Various contingency scenarios and limitations of the algorithm are discussed, and solutions to each of these identified challenges are proposed in further detail.

#### REFERENCES

- [1] S. S. Venkata, and H. Rudnick, "Distribution system-past, future and present," IEEE Power and Energy Magazine, vol. 5, No. 4, pp. 16-22, July/August 2007.
- [2] S. S. Venkata, "Smart Distribution Grid", Tutorial at NPSC 2008, Mumbai, India. [Online]. Available: [http://www.ee.iitb.ac.in/~npsc2008/NPSC\\_CD/Data/Tutorial%201/Smart DistributionGrid.pdf](http://www.ee.iitb.ac.in/~npsc2008/NPSC_CD/Data/Tutorial%201/Smart%20DistributionGrid.pdf).
- [3] S. S. Venkata, A. Pahwa, R. E. Brown and R. D. Christie, "What future distribution engineers need to learn," IEEE Trans. On Power Systems, vol. 19, no. 1, pp. 17-23, Feb. 2004.
- [4] Tony Burge, "Deploying Multiple DA Applications", PAC World Magazine, USA, March 2012.
- [5] Robert Ulski, "Creating Smart DISTRIBUTION through AUTOMATION", PAC World Magazine Cover Story, March 2012.
- [6] P. E. Sutherland, F. R. Goodman, and T. A. Short, "Feeder and Network Evolution for the Distribution System of the Future", in *Proc. IEEE PES T&D Conf.*, pp. 348-353, Dallas, TX, USA, August 2006.
- [7] IEC Standard for Communication Network and Systems in Substations, IEC 61850, 1st ed., 2003-04.
- [8] National Institute of Standards and Technology, Standards Identified for Inclusion in the Smart Grid Interoperability Standards Framework, Release 1.0, Sept. 2009, [Online]. Available: <http://www.nist.gov/smartgrid/standards.html>.
- [9] EPRI Tech. Rep., "Assessment of Wireless Technologies in Substation Functions Part-II: Substation Monitoring and Management Technologies," March 2006.
- [10] P. Parikh, and T.S. Sidhu, "Opportunities and Challenges of Wireless Communication Technologies for Smart Grid Applications," in *Proc. IEEE PES General Meeting*, Minneapolis, USA, July 2010.
- [11] IEEE PSRC Tech. Rep., "Using Spread Spectrum Radio Communication for Power System Protection Relaying Applications," July 2005.





10.22214/IJRASET



45.98



IMPACT FACTOR:  
7.129



IMPACT FACTOR:  
7.429



# INTERNATIONAL JOURNAL FOR RESEARCH

IN APPLIED SCIENCE & ENGINEERING TECHNOLOGY

Call : 08813907089  (24\*7 Support on Whatsapp)