



IJRASET

International Journal For Research in
Applied Science and Engineering Technology



INTERNATIONAL JOURNAL FOR RESEARCH

IN APPLIED SCIENCE & ENGINEERING TECHNOLOGY

Volume: 7 Issue: IV Month of publication: April 2019

DOI: <https://doi.org/10.22214/ijraset.2019.4328>

www.ijraset.com

Call:  08813907089

E-mail ID: ijraset@gmail.com

Gas Monitoring System using Arduino

D. Divyasree¹, G. Abu Bakar²

¹Student, M.Tech in DECS, Dr. K.V. Subba Reddy college of Engineering for Women, Kurnool, Andhra Pradesh, India

²Assistant Professor, Department of ECE (DECS), Dr. K.V. Subba Reddy college of Engineering for Women, Kurnool, Andhra Pradesh, India

Abstract: Recent trend is the development of Smart homes all around the world. Home automation has become very affordable and many people, industries has started to automate daily routines like light, fans, setting the temperature, etc.,. A gas detector is a device that detects the presence of gases in an area, often as part of a safety system. This type of equipment is used to detect a gas leak or other emissions and can interface with a control system so a process can be automatically fan ON. A gas detector can sound an alarm to operators in the area where the leak is occurring, giving them the opportunity to leave. In this connection we fix Gas sensor to servo motor to rotate in 90° rotation to identify gas leakage in different directions. This type of device is important because there are many gases that can be harmful to organic life, such as humans or animals. Gas detectors can be used to detect combustible, flammable and toxic gases, and oxygen depletion. This type of device is used widely in industry and can be found in locations, such as on oil rigs, to monitor manufacture processes and emerging technologies such as photovoltaic. They may be used in firefighting. Gas leak detection is the process of identifying potentially hazardous gas leaks by sensors. These sensors usually employ an audible alarm to alert people when a dangerous gas has been detected. The main objective of the project is to build a Gas leakage detector and monitoring using LPG gas sensor and also connect it with IoT using ESP module for safety and security. Arduino is used as the main controller. The final output of the project is used to detect leakage if gas from cylinders and also notify the user by connecting via IoT software using Blink app.

Keywords: Arduino, ESP Module, Servomotor, Internet of things (IoT), MQ2 sensor, Gas sensor, Gas Detector, Security System, Home Security, Blink app.

I. INTRODUCTION

It has become important factor nowadays to bring the technology into our home and office. By making the place smart, the day-to-day activities are becoming more and easier.

The development of home automation has become mandatory in homes as people are moving towards to the smart home concepts. This is where 'Internet of things (IoT)' comes into picture. As only the regular works has become smart, the things used are still the same like Gas cylinder in homes[1].

Even the neighbourhood is affected in a single accident. So there comes the need to bring in technology to prevent accidents. IoT is a fast-growing technology in Industries, Cars.

IoT is basis for Industry 4.0 development The primary objective of the project is to detect the gas leakage of LPG cylinders, which are commonly used in Indian homes, and alarm the user and the surrounding neighbourhood using IoT. Open source IoT software called "Blinkapp" is used for this project. The software has feature to connect with Arduino and can also connect the user's mobile and social media like twitter, to send notification.

The people in the neighbourhood can also be included in case of an emergency. MQ2 LPG gas sensor is used for input. A 12V buzzer is connected along with the circuit to indicate the user offline[2]. The gas leakage event may involve danger for life. There have been many deaths around the world because of gas leakage. Thus, it is ensured that one doesn't have to worry about the gas leakage becoming so intense and out of control that it can causes damage to life or the surrounding environment and also notifying and alerting the employees or residents about the gas leakage.

It gives a HIGH output when LPG, i-butane, propane, methane ,alcohol, hydrogen and smoke gas is sensed. A potentiometer is also used for controlling sensitivity of gas sensing. This module is very easy to interface with microcontrollers and arduino and easily available in market by name "LPG Gas Sensor Module".

II. STATEMENT OF THE PROBLEM

The work aims at designing a comparatively low cost, easy to manufacture, portable yet efficient gas leakage and monitor system that will ensure adequate security for households, offices and industries[3].

III. METHODOLOGY

The goal of the project is to develop a smart automatic gas leakage detection and monitoring system. The system is designed for homes, offices, industries etc. In this system, there will be an alert system for every individual floor. It is designed to detect sudden gas leakage. It will contain necessary sensors for detecting gas leakage[4]. When the system will detect gas leakage for a room it will take following steps.

- 1) Scan Gas & Display in LCD After activation, the device will continuously scan gas and show the result in the LCD display. If there is no gas, then the display will show - 'No Gas Leaking'. If there is any gas found, the display will show - 'Gas leaking'[5].
- 2) Detection of Gas: If there is presence of any gas the display shows 'Gas Alert'.
- 3) Start Alarm
- 4) When the sensor finds any gas leakage in room or where the device is installed, it immediately sends notification on blink app in mobile. There will be an automatic messaging system.
- 5) Stop Alarm & Reset: If the gas sensor cannot find any gas leakage, then it shows that there is no gas leaking and keeps on scanning for gas.

Block Diagram

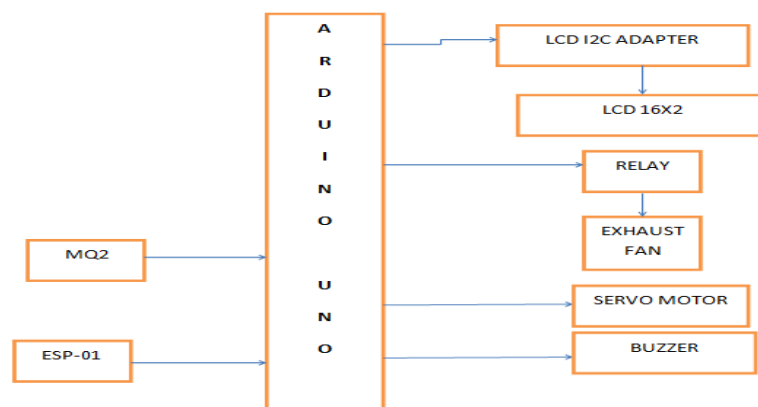

Fig1. Block diagram of Gas Monitoring system using Arduino

A. Circuit Connections

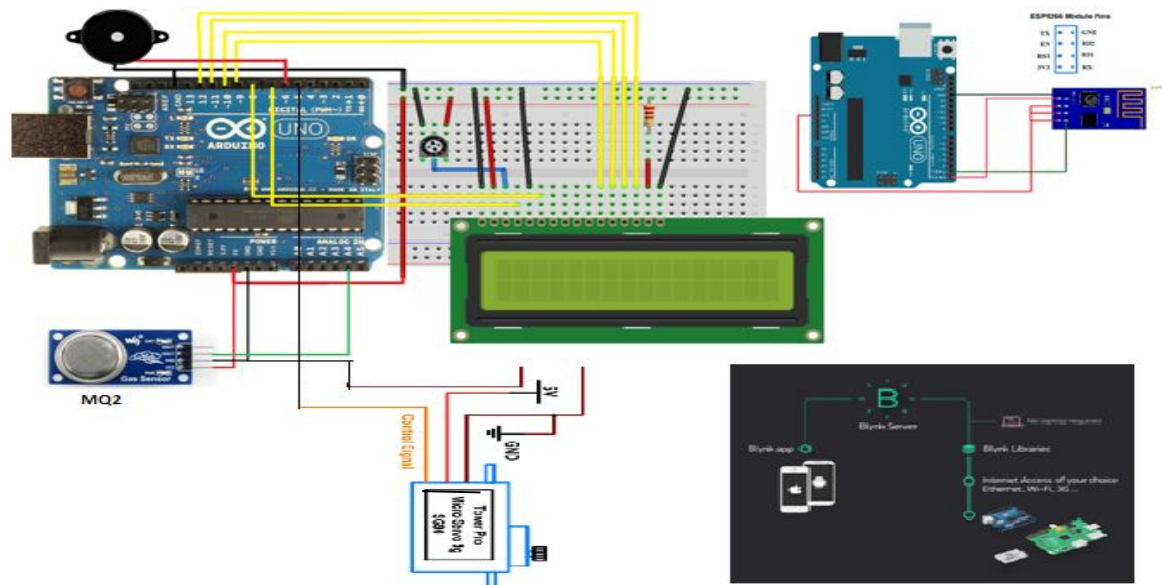

Fig2. Circuit Diagram and Description

As shown in the schematic diagram above Fig 2, it contains Arduino board, LPG GAS Sensor Module, buzzer and 16x2 LCD module. Arduino controls the whole process of this system like reading LPG Gas sensor module output, sending message to LCD and activating buzzer. We can set sensitivity of this sensor module by inbuilt potentiometer placed on it[6]. LPG gas sensor module's DO pin is directly connected to pin 18 (A4) of Arduino and Vcc and GND are connected to Vcc and GND of Arduino. LPG gas sensor module consists a MQ2 sensor which detects LPG gas. This MQ2 sensor has a heater inside which needs some heater supply to heat up and it may take up to some time to get ready for detecting LPG gas. A 16x2 LCD is connected with Arduino in 4-bit mode. Control pins RS, RW and En are directly connected to Arduino pins 2, GND and 3. And data pins D0-D7 are connected to 4, 5, 6, 7 of Arduino. A buzzer is connected with Arduino pin number 13. A servo motor is an electric device used for precise control of angular rotation. It is used in applications that demand precise control over motion, like in case of control of a robotic arm. The rotation angle of the servo motor is controlled by applying a PWM signal to it. By varying the width of the PWM signal, we can change the rotation angle and direction of the motor[7].

We have used a LPG gas sensor module to detect LPG Gas. When LPG gas leakage occurs, it gives a HIGH pulse on its DO pin and Arduino continuously reads its DO pin. When Arduino gets a HIGH pulse from LPG Gas module it shows "LPG Gas Leakage Alert" message on 16x2 LCD and activates buzzer which beeps again and again until the gas detector module doesn't sense the gas in environment. When LPG gas detector module gives LOW pulse to Arduino, then LCD shows "No LPG Gas Leakage" monitoring and control using IoT based Blinkapp[8].

IV. COMPONENT DESCRIPTIONS

A. MQ2 Sensor

A gas detector is a device that detects the presence of gases in an area, often as part of a safety system. Gas Sensor (MQ2) module is useful for gas leakage detection (in home and industry). It is suitable for detecting H₂, LPG, CH₄, CO, Alcohol, Smoke or Propane. Due to its high sensitivity and fast response time, measurements can be taken as soon as possible. The sensitivity of the sensor can be adjusted by using the potentiometer[9].



B. Microcontroller-ATMEGA328

The high-performance Atmel 8-bit AVR RISC-based microcontroller combines 32KB ISP flash memory with read-while-write capabilities, 1KB EEPROM, 2KB SRAM, 23 general purpose I/O lines, 32 general purpose working registers, three flexible timer/counters with compare modes, internal and external interrupts, serial programmable USART, a byte-oriented 2-wire serial interface, SPI serial port, 6-channel 10-bit A/D converter (8-channels in TQFP and QFN/MLF packages), programmable watchdog timer with internal oscillator, and five software selectable power saving modes[10]. The device operates between 1.8-5.5 volts.

ATmega328- FEATURES Flash (kBytes):32 kBytes

Pin Count:32

- 1) Max. Operating Freq. (MHz):20 MHz
- 2) CPU:8-bit AVR
- 3) Max I/O Pins:23
- 4) Ext Interrupts:24
- 5) Power up timer and oscillator start up timer.



C. Wifi Module (ESP 8266)

The ESP8266 WiFi Module is a self contained SOC with integrated TCP/IP protocol stack that can give any microcontroller access to your WiFi network. The ESP8266 is capable of either hosting an application or offloading all Wi-Fi networking functions from another application processor[11]. Each ESP8266 module comes pre-programmed with an AT command set firmware, meaning, you can simply hook this up to your Arduino device and get about as much WiFiability as a WiFi Shield offers. The ESP8266 module is an extremely cost effective board with a huge, and ever growing, community.



D. ARDUINO

Arduino is a computer hardware and software company, project, and user community that designs and manufactures microcontroller kits for building digital devices and interactive objects that can sense and control objects in the physical world. Arduino programs may be written in any programming language with a compiler that produces binary machine code. Atmel provides a development environment for their microcontrollers, AVR Studio and the newer Atmel Studio, which can be used for programming Arduino. The Arduino project provides the Arduino integrated development environment (IDE), which is a crossplatform application written in the programming language Java[12]. A program written with the IDE for Arduino is called a "sketch". Sketches are saved on the development computer as files with the file extension .ino. The Arduino IDE supports the languages C and C++ using special rules to organize code.



E. Servo Motor

A servo motor is an electric device used for precise control of angular rotation. It is used in applications that demand precise control over motion, like in case of control of a robotic arm.

The rotation angle of the servo motor is controlled by applying a PWM signal to it.

By varying the width of the PWM signal, we can change the rotation angle and direction of the motor.

For more information about Servo Motor and how to use it, refer the topic Servo Motor in the sensors and modules section.



F. Liquid Crystal Display

LCD (Liquid Crystal Display) screen is an electronic display module and find a wide range of applications. A 16x2 LCD display is very basic module and is very commonly used in various devices and circuits. These modules are preferred over seven segments and other multi segment LEDs. The reasons being: LCDs are economical; easily programmable; have no limitation of displaying special & even custom characters (unlike in seven segments), animations and so on.



G. I2C Adapter

IIC/I2C Interface Adapter Module is used for 16x2 LCD Display. It uses the PCF8574T IC chip which converts I2C serial data to parallel data for the LCD display. Also this interface module simplifies connecting an Arduino to a 16x2 Liquid Crystal display using only 4 wires.

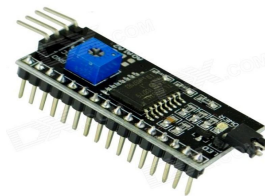

V. FLOW CHART FIGURE

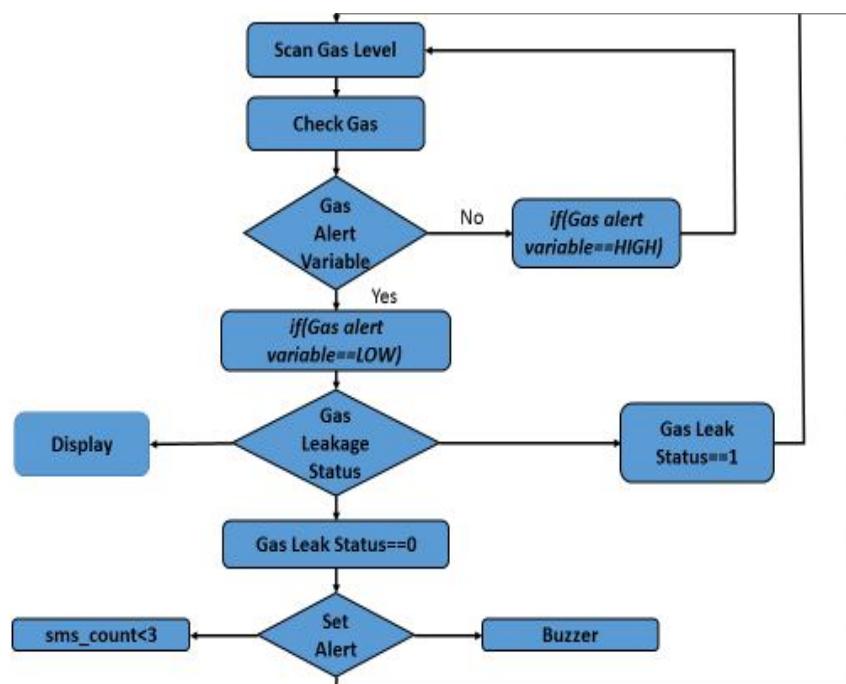

Figure 3: Flowchart for Gas Leakage Detector

VI. IMPLEMENTATION

Internet Of Things (IOT) The ability of various things to be connected to each other through the Internet or It is network of physical devices (vehicles, building) connected to embedded device (software, sensor) through internet.IOT allows the object to sensor collect remotely across network of infrastructure. As shown in fig.4 IOT contains various domains , protocols , application. The interconnection of these embedded devices is expected

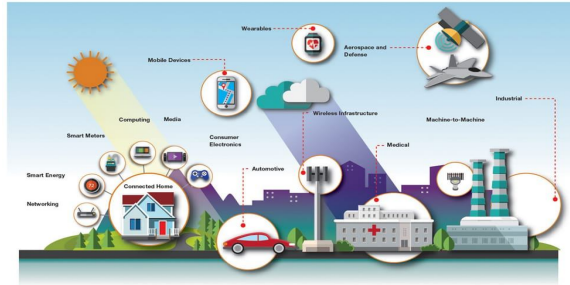

Fig 4: Basic IOT diagram

to usher in automation in nearly all fields, while also enabling advanced applications like a smart grid and expanding to the areas such as smart cities. At the same time, IOT is strongly tied to the big data era due to the enormous data that the “Things” can generate. For the interconnection of these devices, different wired or wireless standards exist[13]. IOT provide various residential and enterprises solution through latest technology .It broadly covers M2M communication, smart grids, smart building, smart cities and many more application. Using IOT in smart cities/smart buildings can certainly provide reliable and efficient solutions as it will allow the user to interact with the entities.

Blynk was designed for the Internet of Things. It can control hardware remotely, it can display sensor data, it can store data, vizualize it and do many other cool things.

There are three major components in the platform:

- 1) *Blynk App*: allows to you create amazing interfaces for your projects using various widgets we provide.
- 2) *Blynk Server*: responsible for all the communications between the smartphone and hardware. Blynk works over the Internet. This means that the hardware you choose should be able to connect to the internet. Some of the boards, like Arduino Uno will need an Ethernet or Wi-Fi Shield to communicate, others are already Internet-enabled: like the ESP8266, Raspberri Pi with WiFi dongle, Particle Photon or SparkFun Blynk Board

Button:

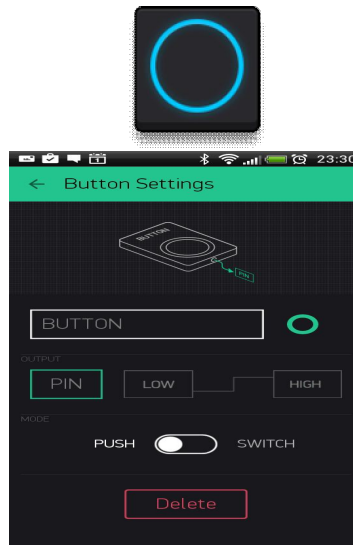

Works in push or switch modes. Allows to send 0/1 (LOW/HIGH) values. Button sends 1 (HIGH) on press and sends 0 (LOW) on release.

This project enables you to control the Arduino pins using ESP8266-01 WiFi module and Blynk App. Blynk App is very easy to use and is great way to begin learning about IoT.

- a) Step 1: Gather Everything
- b) Step 2: Installing Arduino IDE and libraries
- c) Step 3: Flashing ESP8266 Firmware
- d) Step 4: AT Command
- e) Step 5: Blynk App Setup

VII. CONCLUSION

This system provides a control action monitoring by using IoT and it activates the alarm and also sends alert messages to the users within a short time. It is an economical system which can be installed in apartments, hotels and wherever it is needed. The cost of the proposed system is lesser than the commercially available detectors in the market. We have also proposed a new system which monitors human density within the plant area[14]. Therefore Integrated plant safety monitor system based on Arduino can realize workers attendance registration, Real-time precise positioning, Dynamic gas concentration monitoring, Real-time data transmission & Danger alarm. But day by day, its necessity is increasing. Gas leakage detection system is commonly use in home, commercial and industrial sectors and high raised buildings also. In this system, we have described a new approach for gas leakage detection and monitoring system at a low concentration. The leakage is detected with the help of gas sensors. It also sends notification messages to the users which can alert the users that there is gas leakage in the floor. In the other view of point, a gas leakage detection system with monitoring and alarm is costly device[15]. Some people imported this kind of device from abroad which is much costly. But the designed project is an fig.5 shows Arduino Based Gas Leakage Detector with monitoring and Sound Alarm which is very cost effective and can be made easily.

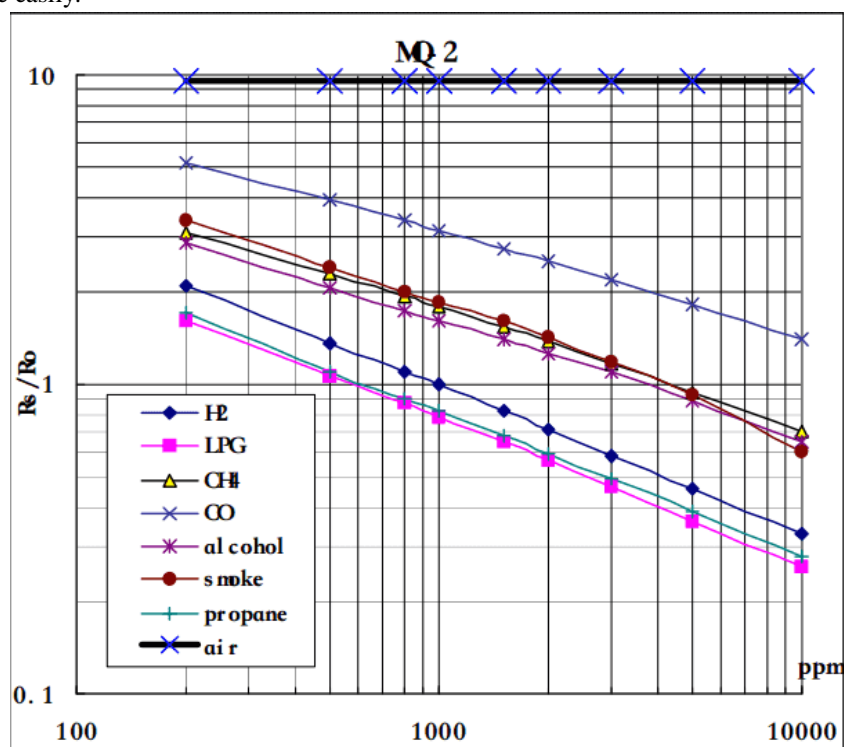

Fig.5 : Graph showing sensitivity curve of MQ2 Gas Sensor

VIII. FUTURE SCOPE

In addition to the developed system, the system can be enhanced by adding a control element which controls the gas leakage if it exceeds the specified upper explosive level for the various gases in the plant area. This can be achieved by any gas leakage indication in any part of the plant alerts the control room and then the control valve is shut off. Therefore preventing any hazard arising due to gas leakage.



REFERENCES

- [1] <http://www.ulcrobotics.com/products>
- [2] [http://www.piacr.tk/Introduction to Pipe Inspection and Cleaning Robot](http://www.piacr.tk/Introduction%20to%20Pipe%20Inspection%20and%20Cleaning%20Robot)
- [3] <http://www.sciencedirect.com/science/article/pii/S0094114X06002254>
- [4] Jeffrey Wong, Haruo Noma, Kiyoshi Kogure, Ebrahim A. Soujeri, Harikrishnan A. I., Rahim Rajan, Sumi M., "Design of a zigbee-based RFID network for industry applications", proceedings of the 2nd international conference on Security of information and networks, 2009, pp. 111-116.
- [5] Fabio Graziosi, Fortunato Santucci, Marco Di Renzo, Stefano Tennina, "Locating zigbee nodes using the tis cc2431 location engine: a testbed platform and new solutions for positioning estimation of wsns in dynamic indoor environments"
- [6] MSA Gas detection hand book, 2008
- [7] Dos Santos, P., Azevedo-Perdicoulis, T., Ramos, J., Jank, G., De Carvalho, J., & Milhinhos, J. (2010). Gas Pipelines LPV Modelling and Identification for Leakage Detection. In Proceedings of the 2010 American Control Conference Year.
- [8] Kariminezhad, H., Parvin, P., Borna, F., & Bavali, A. (2010). SF6 leak detection of high-voltage installations using TEA-CO2 laser-based DIAL. Optics And Lasers In Engineering, 48(4), 491-499. <http://dx.doi.org/10.1016/j.optlaseng.2009.08.011>
- [9] Fire and Gas System Engineering –Performance Based Methods for Process Facilities , ISA manual, 2011
- [10] Ligu, Z., Shutao, W., Yutian, W., & Mingli, S. (2010). Study of Differential Absorption Optical Fiber CH4 Gas Sensor System Based on Optical Fiber Grating. Piezoelectrics And Acoustooptics, 32, 181-183.
- [11] Ramya, V. (2012). Embedded system for Hazardous Gas detection and Alerting. International Journal Of Distributed And Parallel Systems, 3(3), 287-300. <http://dx.doi.org/10.5121/ijdps.2012.3324>
- [12] Protection Analysis Eric William Scharpf, The Instrumentation, Systems, and Automation Society (May 1, 2002) Year of Publication: 2012
- [13] Jadin, M., & Ghazali, K. (2014). Gas Leakage Detection using Thermal Imaging Technique. In UKSim-AMSS 16th International Conference on Computer Modelling and Simulation.
- [14] Prof. K.R.Katole 'Hazardous Gas Detection using ARDUINO', International Journal of Science Technology & Engineering, ISSN (online):2349-784X, Volume 2, Issue 10, April 2016.
- [15] Anitha A, 'Home security system using internet of things', IOP Conf. Series: Materials Science and Engineering, 14th ICSET 2017 - 263042026 doi:10.1088/1757 899X/263/4/042026.



10.22214/IJRASET



45.98



IMPACT FACTOR:
7.129



IMPACT FACTOR:
7.429



INTERNATIONAL JOURNAL FOR RESEARCH

IN APPLIED SCIENCE & ENGINEERING TECHNOLOGY

Call : 08813907089  (24*7 Support on Whatsapp)