



# IJRASET

International Journal For Research in  
Applied Science and Engineering Technology



---

# INTERNATIONAL JOURNAL FOR RESEARCH

IN APPLIED SCIENCE & ENGINEERING TECHNOLOGY

---

**Volume: 7      Issue: IV      Month of publication: April 2019**

**DOI: <https://doi.org/10.22214/ijraset.2019.4448>**

**[www.ijraset.com](http://www.ijraset.com)**

**Call:  08813907089**

**E-mail ID: [ijraset@gmail.com](mailto:ijraset@gmail.com)**

# Multifunctional Robot using ZigBee

Rohan Kashid<sup>1</sup>, Sagar Kandukuri<sup>2</sup>, Prathamesh Sarode<sup>3</sup>, Anuradha Pawar<sup>4</sup>

<sup>1, 2, 3</sup> Student, <sup>4</sup> Assistant Professor, Dept. of Electronics and Telecommunication, SIES Graduate School of Technology, Nerul, India

**Abstract:** At present robots with wireless communication are being rapidly spread and implemented in different fields. This paper presents a Multipurpose Robot which is controlled in a wireless manner through PC using Zigbee wireless mesh network (IEEE 802.15.4) which can be used for automation as well as defense purposes. The robot is embedded with PIC16f877a (8-bit) series microcontroller for the movement and it has various sensors such as Ultrasonic sensor, Gas sensor, IR flame sensor, PIR sensor and temperature sensor which provide multifunctionalities to it. The output of these sensors alongwith the control buttons for Robot are displayed on an application named Flash Magic.

**Keywords:** PC, Zigbee, PIC16f877a, defense, sensors, Flash Magic.

## I. INTRODUCTION

Over the past few years there has been a vast use of Robotics for various applications. Robots can be used for various purposes such as home automation, industries, medical field and for Defense applications. There are various ways to control the robot such as using Wifi, Bluetooth and Zigbee standards. In our Project we have various sensors which are used for specific applications such as obstacle detection, gas leakage detection, flame detection and temperature measurement. Nowadays there are various applications that require a number of low-cost nodes for communicating to cover a large area, and they must operate unattended for years on very low batteries.

Due to these features, Zigbee can be used which is an IEEE 802.15.4 standard operating at 2.4GHz and is used in Wireless Personal Area Networks (WPAN). Zigbee's capabilities are more limited than other WPANs and WLANs – they have small frame sizes, low bandwidth, and low transmit power. Zigbee is used at radio-frequency applications which require a low data rate, long battery life, and secure networking. For these reasons, Zigbee is chosen as the communication medium for the robot.

In this paper we propose a Multifunctional Wireless robot using Zigbee wireless mesh network controlled through a remote PC. This robot can be used for Obstacle Detection, sending information about the temperature conditions and places where human beings cannot reach.

This robot makes use of two Zigbee modules for communication alongwith two PIC16f877a microcontrollers. One of the Zigbee module acts as a transmitter which is connected to PC while the other acts as a Receiver which is connected to the Robot base. The robot has various sensors attached to it and their outputs are displayed on the PC alongwith the control movements for robot with the help of an application named Flash Magic terminal. The system also provides buzzer to alert about the critical situation for the safety.

## II. LITERATURE SURVEY

There are many works on Zigbee controlled robot through PC which are available in the literature. In this chapter, surveys of related works on the above fields are discussed. The authors research on Zigbee controlled robots are as follows:

A. *SPY-Robot based on ZIGBEE- Preksha Vijay, Prem Ranjan, Rohit Arora, Sharvan Suthar Department of Electronics & Communication Engineering, Poornima College of Engineering, Rajasthan, India [1].*

This paper describes about a Wireless Robot based on Zigbee which can be used for spying purposes. The robot is embedded with an ATMEGA8 microcontroller and it has sensors such as ultrasonic and gas sensors which can be used for obstacle detection and gas leakage detection respectively. A camera is attached to the robot for spying purposes. The robot can be controlled in a range of 40 meters using the ZIGBEE transmitter/receiver. It can be used in various applications like Military applications, Landmine detection, Firing situations, Wireless security and surveillance in hot spots, Search and rescue operation, Maneuvering in hazardous environment.

B. *Unmanned Multi-functional Robot Using Zigbee Adaptor Network for Defense Application- Premkumar M [2].*

This paper describes about an Intelligent Unmanned Robot (IUR) using Zigbee which saves human life and reduces manual error in defense side. The robot is specially designed to save human life and protect the country from enemies. In this system, the communication is done with the help of the Zigbee wireless communication network. In this project, the robot is monitored by using

a camera. The entire control is resided within the microcontroller. Various functions such as bomb detection, bomb diffusion, gas leakage detection, live human body detection and pressure gun are included. The robot can move through the rough surfaces also. The robot can be controlled from remote location by using a computer. When control signal commands are given from computer it is transmitted with the help of transmitter Zigbee module. Video receiver receives the video signals from camera. The system also contains temperature sensor for temperature detection.

### III. PROPOSED SYSTEM

#### A. Objective of the Project

The main objective of our project is to design a Multifunctional Robot using Zigbee Protocol which can be controlled through a remote PC. To achieve this, two Zigbee modules alongwith two PIC16F877A microcontrollers are used. One of these Zigbee modules and a PIC microcontroller acts as a Transmitter while the other setup is at the receiver side of the robot. The Transmitter module is connected to the PC through which we can give commands to the receiver PIC microcontroller to drive the robot in forward(f), backward(b), left(l), right@ directions and stop(s). The Receiver side as said consists of Receiver Zigbee module with another PIC microcontroller which controls the outputs of the ultrasonic sensor, PIR sensor, Gas sensor, Temperature sensor and IR flame sensor and Driver output(L293D). As PIC16f877a requires 5V regulated power supply so we use a LM7805 voltage regulator which regulates 12V DC power supply for the robot. Thus the Zigbee modules are used as Wireless Communication Standard and hence controls the movements of the robot through PC using Flash Magic terminal.

#### B. Block Diagram

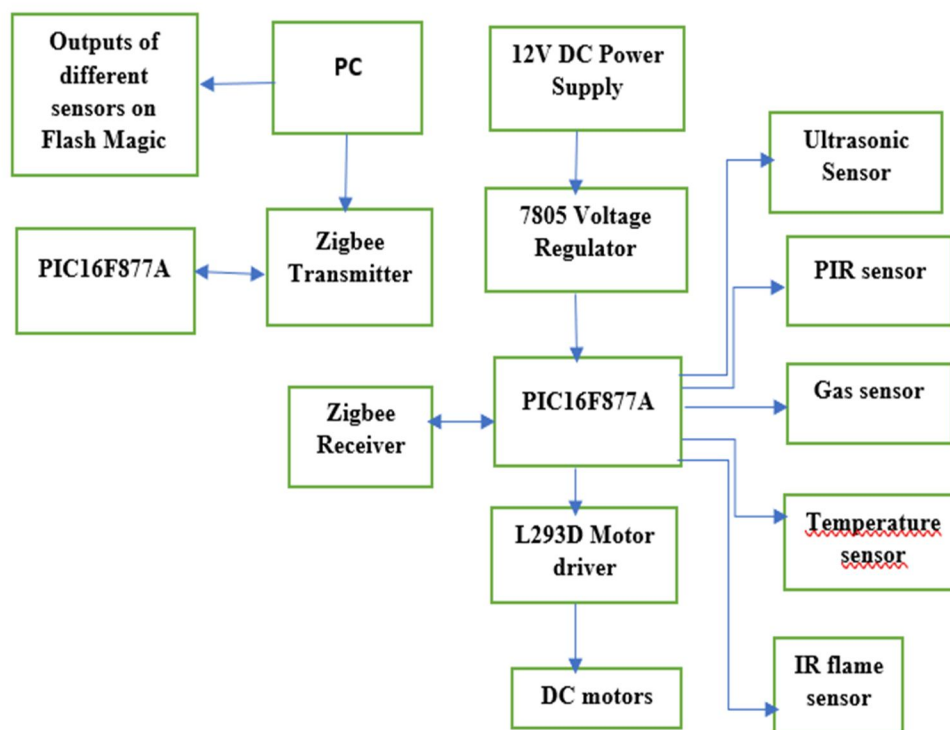

Fig. 1 Block Diagram

Fig. 1 shows the Block Diagram of the whole system which consists of various components. It consists of two PIC16f877a microcontrollers, two Zigbee modules, DC motors, ultrasonic sensor, PIR sensor, Gas sensor, Temperature sensor, IR flame sensor, 12V DC power supply, 7805 Voltage regulator and L293D motor driving circuit. The PC is used for displaying the results and control movements of robot. The transmitting module consists of the push buttons that send the commands to the receiving module for controlling the movement of the robot either to stop, move left, right, forward, backwards. The remote Zigbee transmitter has a range of around 30-100m(approx.) that transmits the signals to Zigbee receiver.

A detailed description of the components used in this project is given as follows:

1) *PIC 16F877A Microcontroller*



Fig. 2 PIC 16F877A

The PIC16f877a microcontroller is the brain of the wireless ZigBee robot system. PIC16F877A is manufactured by Microchip. This chip is selected because of its small size and it is equipped with sufficient output ports without having to use a decoder or multiplexer, portability and low current consumption. It has built-in PWM which allow us to vary the duty cycle of DC motor driver [3]. It also contains of two 8-bit and one 16-bit timer and it has five ports. This microcontroller uses FLASH memory technology due to which we can write-erase programs as many times as possible.

2) *Zigbee*



Fig. 3 ZigBee

In this project, two ZigBee modules are used. One of them is used as a Transmitter while the other is used as a Receiver. The ZigBee circuit uses 3.3 V DC supply. This low dc voltage can be obtained by feeding the output to the voltage regulator LM7805. This low voltage input is one of the advantages of using ZigBee in autonomous robot because the battery life time will be retained much longer. In these modules, five pins are used for communication which are Tx (RC7), Rx (RC6), 5V, GND and reset [3]. ZigBee operates on 2.4GHz spectrum and it has operating current of around 45-50 mA and RF data rate of 250 kbps.

3) *Ultrasonic Sensor*



Fig. 4 Ultrasonic sensor

Ultrasonic transducers are transducers that convert ultrasound waves to electrical signals or vice versa [6]. Ultrasonic sensor HC-SR04 is used to measure the distance by using ultrasonic waves. The sensor emits an ultrasonic wave and receives the wave reflected from the target and thus it measures distance to the target by measuring time between emission and reception.





8) *L293D Motor Driver IC*

Fig. 9 L293D IC

L293D is a quadruple high-current half-H driver. This device is designed to drive a wide array of inductive loads such as relays, solenoids, DC and bipolar stepping motors, as well as other high-current and high-voltage loads [4]. This driver IC is used to control the DC motors of the robot. It acts as an interface between the PIC16f877a microcontroller and motors. It consists of two H-Bridge which are used to control a low current rated motor.

9) *LM7805 Voltage Regulator*

Fig. 10 LM7805

The LM7805 is a three terminal positive voltage regulator which supplies current of 1.5A and output voltage range of 5V. It is used to regulate and provide 5V DC output to the PIC16f877a microcontroller.

10) *Buzzer*

Fig. 11 Buzzer

A Buzzer is an audio signalling device and it is used in alarm devices, timers, etc. In our system we have used the buzzer to beep on the detection of Flame.

#### IV. SIMULATION AND PROGRAMMING SOFTWARES

##### A. MPLAB IDE

MPLAB IDE is used for programming the PIC16f877a microcontroller. Here we have used C language for coding. It is used for initializing the PIC, driving the output of DC motors, for sensing of various sensors used in the robot alongwith wireless communication for ZigBee. We have chosen this compiler because it is developed by Microchip and our PIC microcontroller is also developed by the same company. MPLAB IDE is a free, open source tool and hence we have used it for programming.

**B. X-CTU**

X-CTU software is a Windows-based application developed by Digi. Configuration of the ZigBee modules for communication was realized using a specialized interface X-CTU [5]. The ZigBee modules which we are using are also developed by Digi. This software is used for range test, terminal test and configuring of the two ZigBee modules one as a transmitter and the other as a receiver. The X-CTU goes hand in hand with the Zigbee modules.

**C. Proteus**

The Proteus software is used for the simulation purpose of the transmitter and receiver modules. Before building the original hardware circuit of the project, we use this software to design our circuit and check for correct output. Also, we built our PCB using this same software.

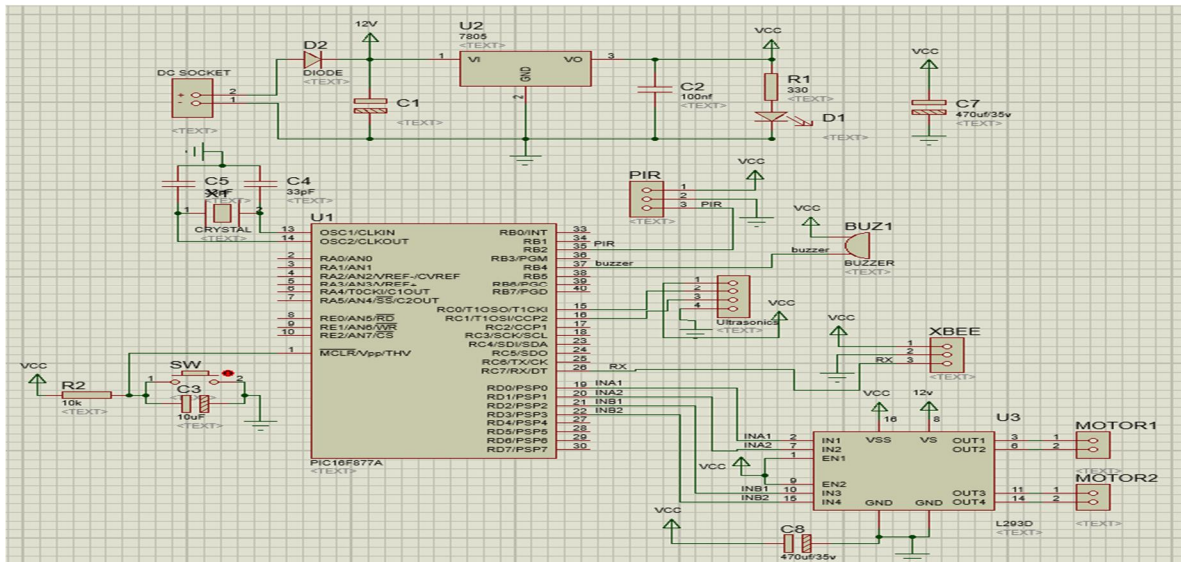

Fig. 12 Receiver side of Robot

**D. Flash Magic**

Flash Magic application is used for programming flash-based microcontrollers using a serial or Ethernet Protocol. It is used to access the COM ports and design our own application to control the robot via it's Terminal. Basically we have used this our Graphical User Interface (GUI) to control the movements of the Robot.

**V. RESULTS and PROJECT SNAPSHOTS**

**A. Results of the Project**

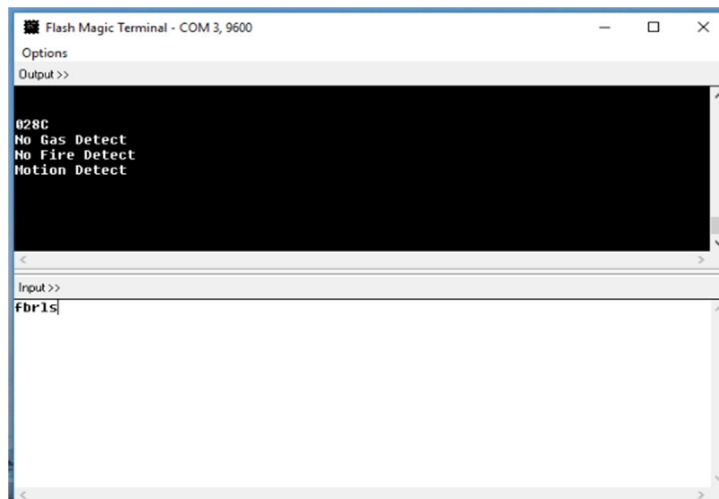

Fig. 13 GUI output window

As shown in the above fig.13, the output of various sensors such as Ultrasonic sensor for motion detection, Temperature sensor for temperature measurement, Gas sensor for Gas leakage detection and Flame sensor for flame detection is displayed on the GUI. Also, the input commands for controlling the robot such as f- forward, b-backward, r-right, l-left and s- stop are given using the same Flash magic application. The robot control and output of various sensors was successfully observed for the ZigBee controlled Robot.

### B. Project Snapshots

The Transmitter Module and Receiver Module alongwith the whole project snapshots are shown in the below figures:

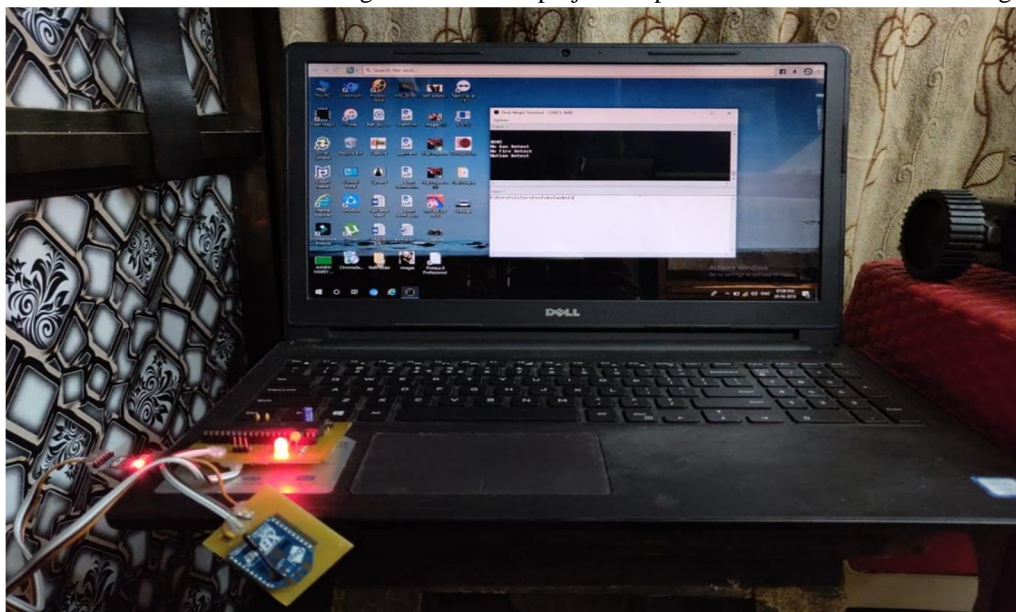

Fig. 14 Transmitting module connected to PC

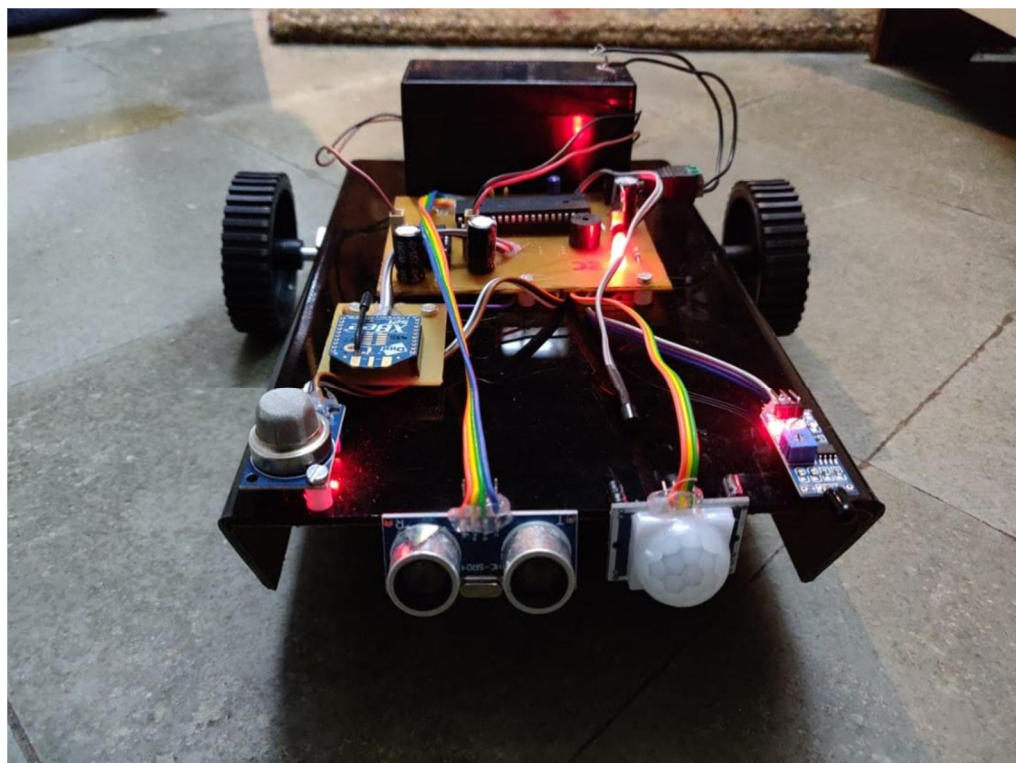

Fig. 15 Receiver module connected to the base of Robot



## VI. CONCLUSION AND FUTURE SCOPE

Based on the above results the implementation of the Multifunctional Robot Using the Zigbee Wireless Protocol was achieved successfully. It has been developed by integrating the features of all hardware components used. This system can be used for various applications in the field of home automation, military services, industries and many more.

In this paper, we have only used Zigbee modules as a communication medium for the Robot but we can improve this system by using additional wifi modules, GSM/GPRS modules to Zigbee to achieve long range of transmission and control. A camera can be attached on top of the robot base which can be used in surveillance. Then this system can be both power efficient as well as suitable for long range communication control of the Wireless Robot.

## REFERENCES

- [1] Preksha Vijay, Prem Ranjan, Rohit Arora, Sharvan Suthar, "SPY-Robot based on ZIGBEE," National Journal of Advanced Research, Volume 3; Issue 1; January 2017; Page No. 25-28.
- [2] Premkumar M, "Unmanned Multi-Functional Robot using Zigbee adopter network for defense application," International Journal of Advanced Research in Computer Engineering & Technology (IJARCET), Volume 2, Issue 1, January 2013.
- [3] Zulkhairi Mohd.Yusof, Muhammad Firdaus Soed, Mohamad Shaiful Osman, Wan Mansor Wan Muhamad, "Wireless Mobile Robot Navigation using Zigbee Protocol," Research gate.
- [4] Divya Velar, Madhulika Rai, Bhagyashree Vedhekar, Prachi Patil, Prof. Mahalaxmi Palinje, "Multifunctional Robot Using Zigbee," International Journal For Technological Research In Engineering, Volume 3, Issue 7, March-2016.
- [5] Rodica Mihaela TEODORESCU, Ion Bogdan CIOC, Bogdan Andrei VOCHIN, Adrian Ioan LITA, "LabVIEW Application Used for Remote Control of a Mobile Robotwith XBee Communication," Electronics, Computers and Artificial Intelligence( ECAI), 2016-International Conference-8thEdition, 30 June-02 July, 2016, Ploiesti, ROMÂNIA.
- [6] V. Abilash, J. Paul Chandra Kumar, "Arduino Controlled Landmine Detection Robot," Third International Conference On Science Technology Engineering and Management (ICONSTEM),2017.



10.22214/IJRASET



45.98



IMPACT FACTOR:  
7.129



IMPACT FACTOR:  
7.429



# INTERNATIONAL JOURNAL FOR RESEARCH

IN APPLIED SCIENCE & ENGINEERING TECHNOLOGY

Call : 08813907089  (24\*7 Support on Whatsapp)