



IJRASET

International Journal For Research in
Applied Science and Engineering Technology



INTERNATIONAL JOURNAL FOR RESEARCH

IN APPLIED SCIENCE & ENGINEERING TECHNOLOGY

Volume: 7 Issue: IV Month of publication: April 2019

DOI: <https://doi.org/10.22214/ijraset.2019.4551>

www.ijraset.com

Call:  08813907089

E-mail ID: ijraset@gmail.com

Catastrophe Rescue BOT

T. Madhukar Reddy¹, P. Vishwa Aditya², R. Sai Kumar³, N. Kavitha⁴

^{1,2,3} DEPT. OF ECE, ⁴ Assistant Professor, MVSR Engineering College, Hyderabad, India

Abstract: Disasters whether natural or man-made, play havoc with the lives of thousands of people every year around the world. Their aftermath calculations are nothing but a grim picture of death, destruction, and suffering. The impact of disaster mainly depends upon time i.e. how many people can be saved within the time from the disaster place such as from fire accidents and collapsed buildings. Hence, we designed a catastrophe rescue bot, a multipurpose bot that can be used as an automatic fire extinguisher and to detect the people who got struck among the wreckages. The bot consists of a PIR sensor for live human detection obstacle sensor to avoid the obstacles, a temperature sensor to detect the fire and a water pump to put out the fire automatically. All the components are interfaced with each other using NodeMCU. Camera module and TV tuner cards are used for live streaming and identification of humans. The bot is also equipped with a chain mechanism driven by DC Motors for the movement of the bot in forward and reverse path. The bot movement is controlled with blynk application.

Keywords: Catastrophe, Human Detection, Automatic Fire Extinguisher, NodeMCU, Blynk Application

I. INTRODUCTION

The rescue bot contains both hardware and software interfaced with each other that runs automatically, to save the victims from disaster areas without any delay in the rescue operations. The purpose of a bot is to stop the spreading of fire from one place to another place, to identify people who struck among the wreckages and to save them so that the extent of damage can be prevented. Whenever a disaster occurs, it is very difficult for the rescuers to save the people within time because it requires proper strategic planning and also the narrow entrances don't support the rescue operations^[3]. This manual type of operation is complex, time-consuming and requires a large number of trained people to carry out the rescue operation. This project proposed a mobile-operated an autonomous bot to move in a hazardous environment to detect the people^[1] and to extinguish the fire automatically^[2]. The bot is equipped with advanced sensors for establishing wireless communication so that the bot can move in between narrow passes and fitted with a camera for getting a view of things happening inside the disaster area.

II. EXISTING SYSTEM

From several years, rescue workers are using trained dogs to detect the victims trapped among the wreckage and burning structures but it has several drawbacks^[2]. Dogs can take the rescuer to the victim identified location but it cannot provide any information about victim condition or victim surroundings. And also, this manual operation requires a large number of man power and time consuming.

III. PROPOSED SYSTEM

This project proposes a cost-ineffective autonomous bot equipped with sensors to identify the people and an automatic fire extinguishing system carried with a few workers and it provides an accurate position and situation of people inside the disaster area. Hence everyone can be saved by timely detection and loss of damage can be minimized.

IV. BLOCK DIAGRAM

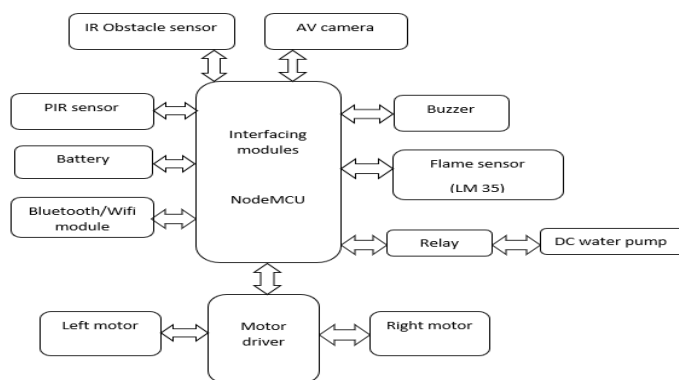

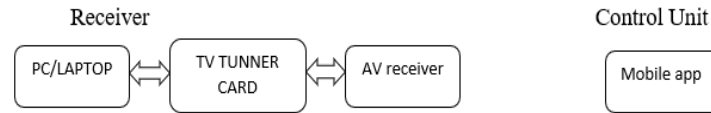

Fig.1 Block Diagram

V. HARDWARE COMPONENTS

A. Buzzer

A buzzer is an electronic signalling device, used in automobile industries, household devices such as a microwave and oven. Buzzer comprises of switches or sensors linked to the control unit which determines, which exact button was pushed and it illuminates a light on the appropriate button and sends a signal in the form of an unceasing tooting.



Fig.2 buzzer

B. PIR Sensor

All the objects whose temperature is above 0k emits heat energy as radiation. This emitted radiation is not perceptible by the naked human eye because it emits radiation at infrared wavelengths, but it can be spotted by electronic devices. PIR detect the motion of the human or a warm body in its range^[4]. PIR sensor is tiny, cost ineffective, consumes low-power and easy to handle. PIR comprises of a pyroelectric sensor, that detects the infrared radiation.

The sensor in the motion detector is divided into two halves. The motive for that is we are using PIR to detect change in object position but not average Infrared levels. The two halves are bound up so that PIR measurements cancel with each other and the average temperature from field view is removed from the electrical signal. If one halves of the sensor receives more IR radiation when compared to the other half of the sensor, output swings from high to low and vice-versa.



Fig.3 Pir sensor

C. IR Sensor

IR sensor is very useful if you are trying to make an obstacle avoider robot or a line follower. In this project, we use a basic IR sensor that can detect an object at a distance of around 2 meters. The working principle of the infrared sensor is completely based on the change in the value of resistance in IR receiver. Here in this sensor, we connect the infrared receiver (photo diode) in reverse bias so that it gives very high resistance if it is not exposed to infrared light. The resistance, in this case, range of(in) Mega ohms, but when infrared light reflected back and fall on the infrared receiver the resistance of the receiver falls from Kilo ohms to 100 ohms. This change in resistance is converted into voltage. This voltage is applied to a comparator IC, which compares it with a threshold level. If the sensor voltage is more than the threshold then the output is high else it is low, which can be used directly for microcontroller.



Fig.4 IR sensor

D. Motor Driver

An L293D IC generally a 16-pin DIP (dual-in-line package). The motor driver integrated circuit can simultaneously control two motors in forward and reverse direction with four microcontroller pins. It works on the principle of H-bridge.

The H-bridge circuit enables the voltage to flow in either course. To pivot the engine in clockwise or anticlockwise bearing the voltage must be changed, Hence H-bridge integrated circuit is suitable for operating a DC motor.

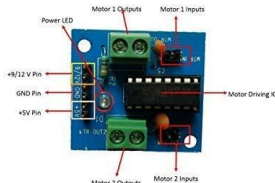

Fig.5 motor driver

An L293D IC consists of two H-bridges to rotate two dc motors separately. Due to its compact size, it is used in robotic applications.

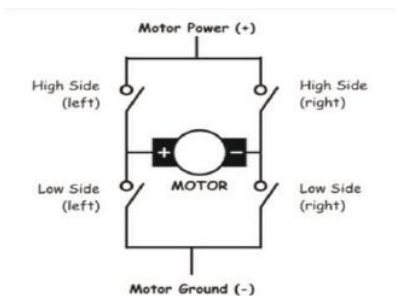

Fig.6 H-Bridge

E. Relay

A relay is an electromechanical switch, which performs both ON and OFF operations automatically. Relays are used to drive a high-power circuit by a low-power electric signal and when the finite number of circuits need to be handled by one electric signal.



Fig.7 relay

F. DC Motor

A DC motor converts electrical energy into mechanical energy, and it runs on dc current. The most common DC motor types are brushed and brushless, which uses internal and external commutation respectively to create an oscillating AC current from the DC source. So, they are not completely DC machines in a strict sense. In this project brushed DC Motor, which operates in the ratings of 12v DC, 0.6A is used.

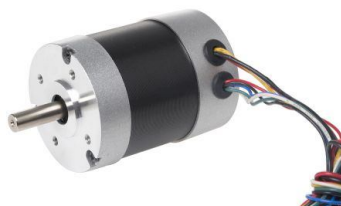

Fig.8 DC Motor

G. Flame Sensor

The flame sensor is used to detect and respond to the presence of a flame or fire, allowing flame detection^[2]. Response to the spotted flame depends upon the connection, and it includes sounding an alarm, disabling a fuel line and starting a fire suppression system. A flame sensor replies quicker and more precisely when compared to a smoke or heat sensor due to its mechanisms in detecting the flame.



Fig.9 Flame Sensor

H. Node MCU

NodeMCU is an open source advancement board and firmware situated in the generally utilized ESP8266 - 12E Wi-Fi module. This is likewise an open source IOT stage. This module is modified with the basic and ground-breaking LUA programming language or Arduino IDE^[5]. With only a couple of lines of code, it permits to set up a Wi-Fi association and characterize input/output pins in like manner by transforming the ESP8266 into a web server and significantly more. It is the Wi-Fi likeness Ethernet module. With USB-TTL, the NodeMCU Development board bolsters legitimately blazing from the USB port. It consolidates highlights of a WIFI Access point, station and microcontroller. These highlights make the NodeMCU a very useful asset for Wi-Fi organizing. It tends to be utilized as a passage or potentially station, has a web server / interfaces with the web to get or transfer information. NodeMCU comes conveniently that joins implicit Wi-Fi support, giving a simple pathway to structure IoT applications according to your specialized necessities.

1) Node MCU Features

- a) Open-source
- b) Arduino-like hardware
- c) Status LED
- d) Micro-USB port
- e) Reset/Flash buttons
- f) Interactive and Programmable
- g) Low cost
- h) ESP8266 with inbuilt WIFI
- i) USB to UART converter
- j) GPIO pins



Fig.10 NodeMCU

I. Camera Module

The camera module containing a web camera is put on the highest point of a bot, and the video flag is transmitted to the PC through AV beneficiary and tuner card. The camera module transmits the video inclusion of the ways and in this way helps in a simple mapping of the way to be taken by the rescue group.

In Progressively applications, a camera of high range is utilized to get great clearness and wide inclusion of territory. the camera helps the bot from stalling out in a pit as the impediments lying in the way is anticipated and the required move can be made promptly, in this way improving the life of the bot in the hazardous situations. Subsequently, because of the camera module, we can watch the bot, and we can see the live vision.



Fig.11 Camera Module

VI. SOFTWARE TOOL

A. Arduino IDE

It is the Integrated Development Environment especially for Arduino where you can compose your Arduino codes and transfer the program onto your Arduino board^[5] or NodeMCU board. It can enable you to discover the errors in your codes. The IDE can also find the COM ports automatically and it gives some examples needed to finish the project. The Arduino code is written in java language. The Arduino IDE also support C and C++.

VII.WORKING OPERATION

The main brain of this project is the NodeMCU, all the components are interfaced to it. In any case, so as to detect fire we utilize the flame sensor module and for live human detection, we use PIR sensor^[1]. When the fire sensor detects the fire in the range of above 55 c it sends an interrupt signal to NodeMCU and it switches the relay. The relay drives a high-powered water pump with a low voltage input signal to put out the fire immediately using water^[2]. Obstacle sensor is used to avoid obstacles. When the radiation emitted by the infrared transmitter, strikes the object, some part of the radiation will reflect back to the receiver. Detection of an infrared signal will trigger the 555 timers, and a buzzer will start beeping. The PIR sensor is utilized to recognize the movement of the human body^[1]. At whatever point a warm body like a human or creature passes by, it first intercepts one portion of the PIR sensor, which causes a positive differential change between the two halves^[4]. At the point when the warm body leaves the detecting territory, the sensor generates a negative differential change. Both halves together indicate there is a human in the sensor area. The NodeMCU is programmed in such a way that when PIR detects human, the buzzer interface to it produces continuous beep sound to indicate the presence of a human in the sensor range to rescuers^[1]. A wireless AV camera is fitted on the top of a bot chassis to get live video streaming of the disaster area. The tv tuner card along with the AV receiver is connected to pc to watch the received video signal. All these components are placed on a chassis which is driven by an L239D motor driver IC that works on the H-bridge principle. The bot is moved to target areas with the help of a wireless control unit Blynk application. With the help of this bot, the rescuers make a thought arrangement and enter the hazardous situation to save the people in advance^[3].

VIII. ADVANTAGES

- A. High sensitivity.
- B. Fast response.
- C. Automatic operation.
- D. Stable performance and long life.
- E. Low power consumption.
- F. Easily operable.

IX. CONCLUSION

Hence by using this bot, many people can be saved in a shorter span of time during fire accidents or building collapse. Since the bot can move in all the directions with the wireless communication technology, these make the framework increasingly successful to utilize. In this project, we designed an accurate and safe system to ensure that all humans are saved during the rescue operation.

X. FUTURE DEVELOPMENT

This bot can be improved by using high range SONAR sensors and high capacity motors. Some more sensors like cell phone indicator, metal identifier and so forth can be connected to make this bot progressively viable.

This circuit is basically implemented on land rovers by making its movement more effective on rough surfaces and in ahead of time this can be used on drones applying the same circuit and idea with advanced techniques.

XI. THE HARDWARE OF THE BOT

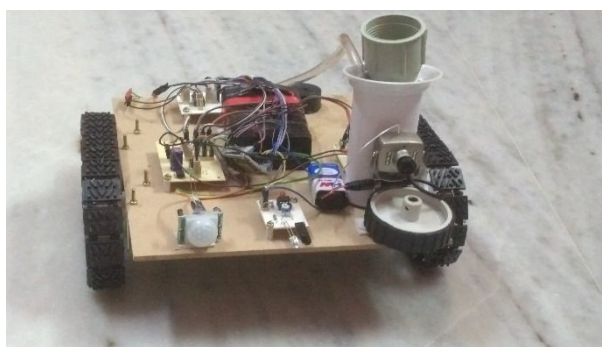

Fig.12 BOT

REFERENCES

- [1] Mittika Ukey, Sonam Gupta, Bhagyashali Masane, Chanchal V. Dahat, "Aive human detection robot in rescue operation", "International Journal of Advanced Research in Electronics and Communication Engineering", volume 5, issue 3, march 2016.
- [2] Sunantha Krishnan, Anthony selva jessobalan, "rescue robot", "international journal of innovations in engineering and technology", volume 2, issue 3, june2013.
- [3] Surbhi, Swathi Priya, Sowandarya, "Rescue Robot-A Study", "International journal of advanced research in electrical, electronics and instrumentation engineering", volume 3, special issue 3, April 2014.
- [4] Human Infrared Signal Recognition Using Single PIR detector-Lihong Wang, Chongqing College of Electrical Engineering Chongqing, China.
- [5] <http://arduino.cc/en/Tutorial/HomePage>.



10.22214/IJRASET



45.98



IMPACT FACTOR:
7.129



IMPACT FACTOR:
7.429



INTERNATIONAL JOURNAL FOR RESEARCH

IN APPLIED SCIENCE & ENGINEERING TECHNOLOGY

Call : 08813907089  (24*7 Support on Whatsapp)