



IJRASET

International Journal For Research in
Applied Science and Engineering Technology



INTERNATIONAL JOURNAL FOR RESEARCH

IN APPLIED SCIENCE & ENGINEERING TECHNOLOGY

Volume: 7 Issue: V Month of publication: May 2019

DOI: <https://doi.org/10.22214/ijraset.2019.5146>

www.ijraset.com

Call:  08813907089

E-mail ID: ijraset@gmail.com

Design, Analysis and Fabrication of Foldable Electric Bike

Shlok Desai¹, Kavan Mehta², Zinal Kheni³, Naitik Bhatt⁴, Rahul Patel⁵

^{1, 2, 3, 4} Department of Mechanical Engineering, Indus University Gujarat, India 382115

⁵ Faculty of Mechanical Engineering, Indus University, Gujarat, India 382115

Abstract: E-bike comprises the features like high mobility efficiency, compact, electrically powered, comfortable riding experience, and light weight vehicle. E-bike is the most versatile future vehicle considering its advantages. The purpose of the research is to find an alternative to improvise human comfort, solve global problems and promote sustainable development. An Electric Bike is a battery-operated vehicle which is economical with low maintenance cost. Using PMDC motor instead of IC engine will reduce harmful emissions and reduction in weight for easy commuting. This research is based on designing of Foldable electric bike, material optimization using various design & simulation software and fabrication of the electric bike by using aluminium 7075 grade material. To meet the above objective first, designing the foldable electric bike in Creo Parametric software based on load/stress acting on it when a person sits on the seat. Then the design will be further analysed for FEA, static analysis to find if the theoretically calculate estimation meets the current scenario and finally fabricated the Foldable Electric Bike.

Keywords: Foldable Electric Bike, Creo parametric, FEA, Static Analysis, Fabrication.

I. INTRODUCTION

Modern world demands the high technology which can solve the current and future problems. Fossil fuel shortage is the main problem now-a-days. Considering current rate of usage of fossil fuels will let its life up to next five decades only. Undesirable climate change is an indication for not to use more fossil fuel any more. Best alternative for the automobile fuels to provide the mobility & transportation to peoples is sustainable electrical bike. Future e-bike is the best technical application as a visionary solution for the better world and upcoming generation. Main reason to identify the need of finding and modifying E-Bike is to overcome the issue of the pollution because of vehicles in metro towns & urban zones is growing uninterruptedly. Considering a class of society it is not reasonable for all to purchase (scooters, mopeds or motorcycles). So, combining both issues, environmental progress supporting and economical affordable alternative would be the best solution. Typical parts of E-bike (Electric Bike) are permanent magnet dc Motor (PMDc Motor), Throttle (Accelerator), Battery, Frame and other common bicycle parts (fig.1). The motor is activated by a throttle with power-on-demand, same as in general scooters or motorcycles. Electric Bike is a battery-operated vehicle which is economical with low maintenance cost and zero pollution. Electric two wheelers use the rechargeable battery that converts the electrical energy into mechanical energy. The battery of an EV can be charged easily using a power connection



Figure1: key components of Foldable electric bike.

II. DESIGN

A. Theoretical Design Calculation

- 1) Battery specifications: 36V, 10 Ah li-ion battery
- 2) Nominal voltage 36V
- 3) Charge voltage 42V
- 4) 7075 aluminium alloy
- 5) $M = \pi/32 \times \sigma \times d^3$

Assuming weight of person $W=80\text{kg}= 0.784\text{kN}$

L =distance between load applied and stress concentrated node

M =moment

d = diameter of the shaft

Therefore,

$$W \times L = \pi/32 \times \sigma \times d^3$$

σ of aluminium 7075 grade

$\sigma = 400\text{MPa}$

Taking $L=0.3\text{m}$ or 300mm

For T_0

$$784 \times 300 = \pi/32 \times 400 \times d^3$$

$$\therefore d = 18.16\text{mm} \approx 19\text{mm}$$

B. Factor Of Safety

FOS=Maximum Stress/Theoretical Stress

$$\text{FOS} = 700/400 = 1.75 \approx 2$$

$$M = \frac{\pi}{32} \times \sigma \times (d_1)^3 (1 - k^4)$$

AFTER TAKING CONSIDERATION FOR FACTOR OF SAFETY IN CALCULATIONS,

Assuming weight of person $W=80\text{kg}= 0.784\text{kN}$

L =distance between load applied and stress concentrated node

d_1 = outer diameter of the shaft

d_2 =inner diameter of the shaft

t = thickness= $d_1-d_2=3\text{mm}$ (assumed)

$k=d_2/d_1$

Therefore,

σ of aluminum 7075 grade

$\sigma = 400\text{MPa}$

ALLOWABLE BENDING STRESS= 228MPa (σ/FOS)

$$\frac{\pi}{32} \sigma \times (d_1)^3 (1 - k^4) = M$$

$$\frac{\pi}{32} \sigma (d_1)^3 \left(1 - \left(\frac{d_2}{d_1} \right)^4 \right) = M$$

By solving above equation we get inner diameter as follows,

$d_2=20\text{mm}$

$d_1=23\text{mm}$

Motor: - Brushless PMDC motor

Power= 250W-350W

Voltage= 24V-36V

$P=VI$

$$I=P/V=250/36= 6.944\text{A (ideal load)}$$

And, $P = \frac{2\pi NT}{60}$

At no load

N=250rpm and V=24V

$\therefore 250 = \frac{2\pi \times 250 \times T}{60}$

$\therefore T = 9.554 \text{ Nm}$

At ideal load

V=36V and N=500rpm

$\therefore 250 = \frac{2\pi \times 500 \times T}{60}$

$\therefore T = 4.77 \text{ Nm}$



III. MODELLING

1) *Creo Parametric Software:* Creo Parametric is a cad-cam software widely used for product design and assembly. Creo Parametric is a software which is widely used for designing various objects like automobile parts, mobile body designing & many other products.

Creo is a family or suite of design software supporting product design for discrete manufacturers and is developed by PTC. The suite consists of apps, each delivering a distinct set of capabilities for a user role within product development.

Creo runs on Microsoft Windows and provides apps for 3D CAD parametric feature solid modelling, 3D direct modelling, 2D orthographic views, Finite Element Analysis and simulation, schematic design, technical illustrations, and viewing and visualization. Modelling helps you which pattern you want to use to get your project completed. Modelling of this Foldable electric bike was done in Creo Parametric software considering the design values which includes inner and outer diameter of the rod, torque exerted by the motor. Modelling is necessary to visualize the figure 5 working and perform analysis based on stress it can handle practically.

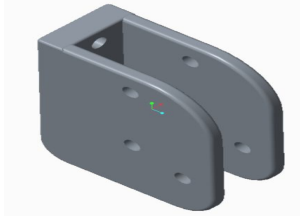
Table1: list of parts made under modelling and their description

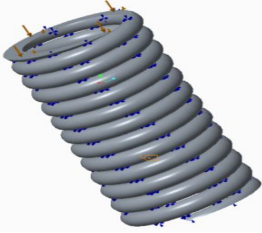
Sr. no	Part name	Description	Part modelling
1	Holding plate	It is key part for folding mechanism. It supports two primary rod.	 <p>Figure 2</p>
2	Rod 1	Primary rod supporting rider. It is fixed at the upper end of the holding plate with the aid of hinge.	 <p>Figure 3</p>
3	Suspension system	Suspension systems must support both road holding/handling and ride quality	 <p>Figure 4</p>

The upper and lower ends of the suspension are sharpened to help in mounting of the suspension to the bike frame. Meshing of the suspension is done to break up the domain into pieces, each piece representing an element. Finite element analysis is performed where analysis of element by element is done based on how each particular element will react based on load given. In this research analysis of how each element of the spring will react to the stresses is shown and then integrated it as a whole.

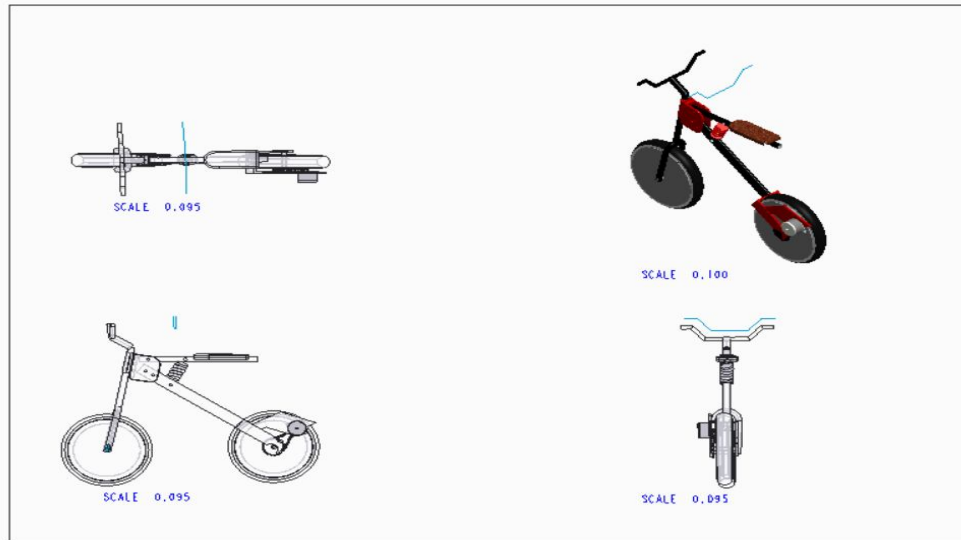

Figure 5: Orthographic view of Foldable Electric Bike

IV. ANALYSIS

Analysis helps you to gather the loopholes of the system before the development process. Analysis of the mono-shock was done in Creo parametric software as static analysis.

Generally, a finite-element solution may be broken into the accompanying three stages.

- 1) *Pre-Processing*: defining the problem,
- 2) *Solution*: Assigning loads, constraints, and solving
- 3) *Post Processing*: further processing and viewing of the results

In this stage one may wish to see

- a) Arrangements of nodal relocations,
- b) Component strengths and moments,
- c) Diversion plots, and
- d) Stress shape outlines

A. Holding Plate Analysis

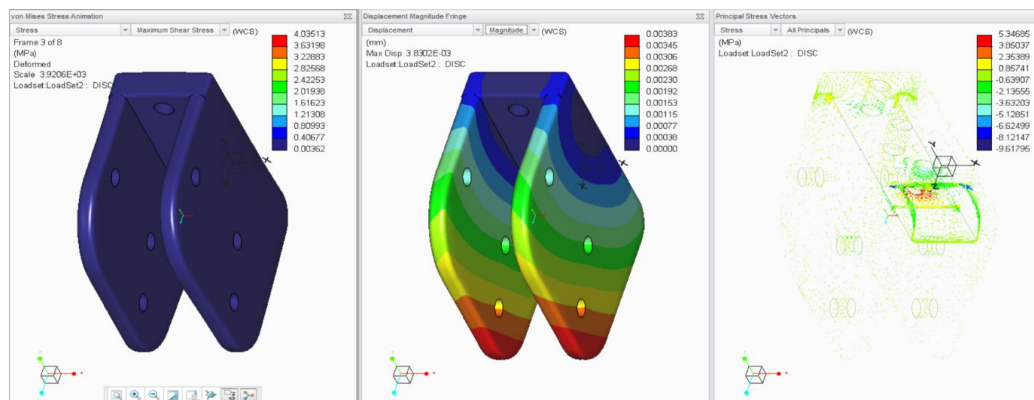

Figure 6 analysis of holding plate

In fig 6 we can observe that the maximum shear stress acting on the plate is .00362Mpa which is negligible. Displacement is observed considerable (at top right corner .00036mm and at bottom left corner .00383mm).

B. Primary Rod 1 Analysis

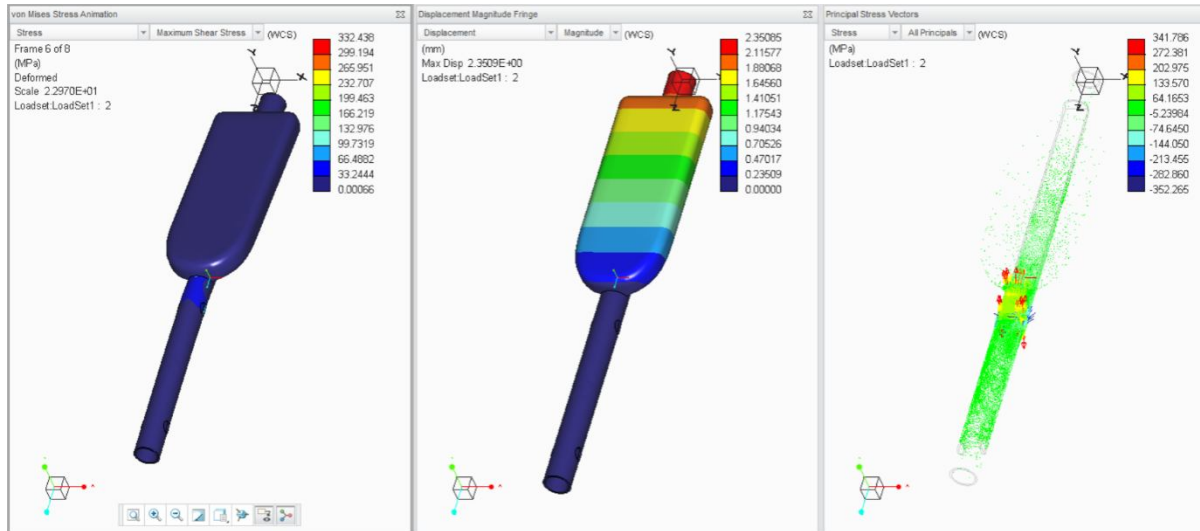

Figure 7 analysis of supporting rod

In fig 7 we can observe that the maximum shear stress acting on the rod1 is 33.244Mpa < 400Mpa which is negligible. Displacement is observed considerable (at the top corner 2.35095 mm and at the bottom corner 0.23509 mm).

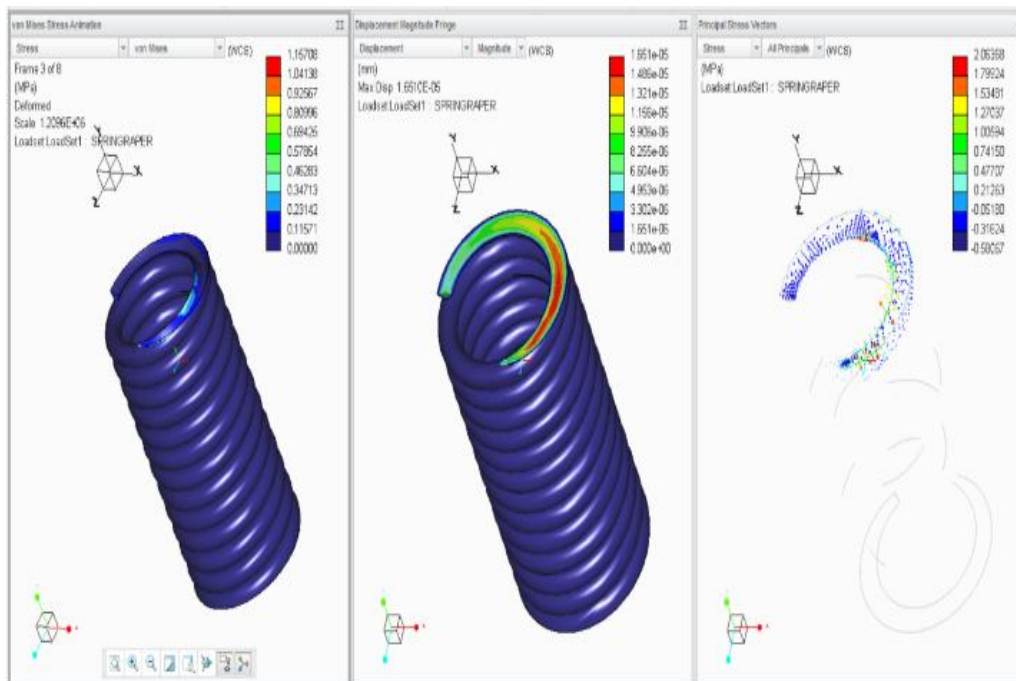

Figure 8 analysis of suspension system

The analysis showed in figure8 is for -686.7N. The stress is induced on the sharp-Edge of the spring and is not extreme for breakage (1.15Mpa < 49.14Mpa). The maximum displacement is shown which happens on the upper face of the spring where the part will interface with the mountings without letting the other coils to deflect. Thus, the analysis proves that the suspension system will only deflect when force is greater than the person’s weight

V. FABRICATION

Manufacturing process used for fabrication of foldable electric bike are as follows:

A. Holding Plate

- 1) **Material Selection:** for our foldable electric bike we wanted material to be light in weight, high strength to withstand weight of rider, cheaper in cost and easily available in the market so we decided to use aluminum 6000 grade plate
- 2) **Method Used:** wire cut EDM. EDM is a process of metal machining in which a tool discharges thousands of sparks to a metal workpiece. Wire cut EDM equipment is run by computer numerically controlled (CNC) instruments, which can control the wire on a three-dimensional axis to provide greater flexibility.

B. Why wire cut EDM?

We had to use this non-conventional method because of the required depth of the plate. Kaizen and Poka-Yoka technique was necessary for maximum precision and finishing.

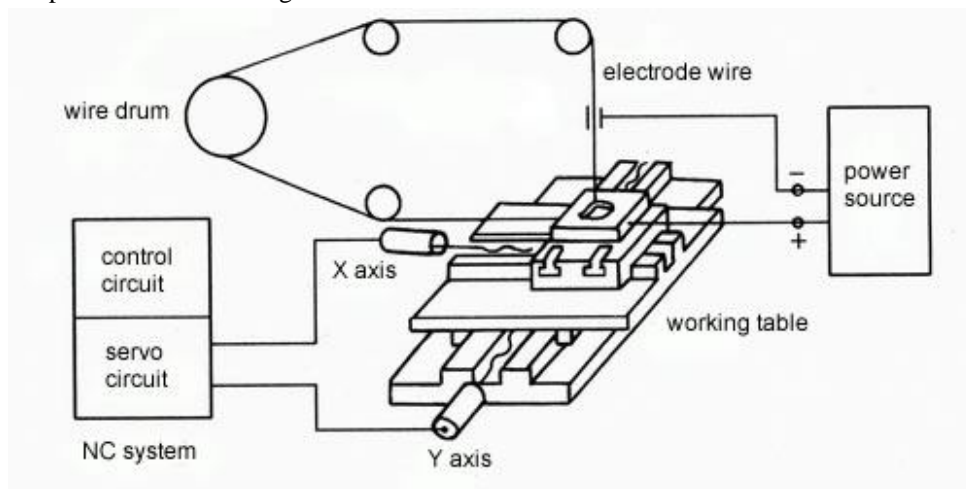

Figure 9 line diagram of wire cut EDM

C. Back Fork

- 1) **Material:** Aluminum 7000 grade
- 2) **Technique used:** TIG welding. Tungsten inert gas (TIG) welding, is an arc welding process that uses a non-consumable tungsten electrode to produce the weld.
- 3) **Why TIG welding?:** For aluminum material TIG welding is most effective welding technique because it provides more strength.

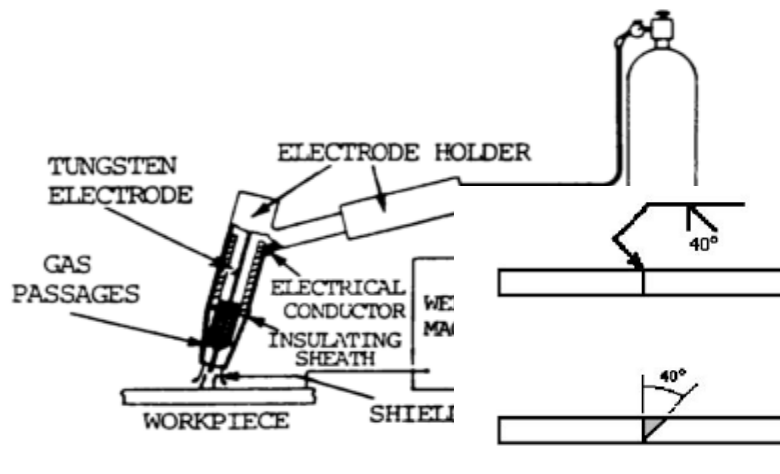

Figure 10 line diagram showing TIG welding

D. Electrical Components

Table 3 showing list of electrical components

Sr. no	Part name
1	PMDC motor(24v,250w)
2	Li ion battery(10ah,24v)
3	Electronic throttle
4	Electronic brakes
5	controller
6	charger
7	headlights
8	on/off command key

E. Folding Mechanism



Figure 11 folded and unfolded Electric bike

Figure 11 shows the foldable electric bike fabricated after considering designed values and analysis.

Table 2: Dimensions of folded and unfolded mechanism

	Sr. no	Folded (ft.)	Unfolded (ft.)
Height	1	4	3
Length	2	1	3
Width	3	0.5	1

VI.CONCLUSION

Overall, after designing (inner, outer diameter, torque, and power), modelling for visualization, analysis to validate testing conditions and finally fabricating this research paper successfully helps manufactures of foldable electric bike to reach their goal with minimum cost constraint, minimum weight and an electric bike that can withstand rough roads. Due to exponential increment of population, foldable electric bikes will be emerge as more convenient mode of transport. In this electric mobility era need of foldable electric bikes is increasing exponentially. The user-based problems like traffic, parking, and fuel as well as few global problems can be solved with the aid of this folding mechanism. This research helps solve global problems and will help people to commute easily. This mechanism helps foldable electric bikes to get more compact and portable so that the user can travel on the electric bike as well as fold it according to situations and requirements.

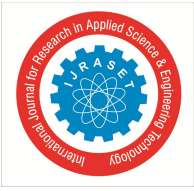

A. Problems related to research of foldable electric bike

The suspension system is particularly designed for foldable electric bike where suspension system is used as primary or secondary folding mechanism. Thus, this suspension system cannot be replaced by other suspension. Rider has to carry bike everywhere wherever he/she goes.

B. Future Prospects

It will be used in big industries to reduce worker's transportation time

It will be used at airports, railways for easy commuting.

It will reduce traffic and parking problems in this fast growing population.

It will promote use of electric vehicles.

REFERENCES

- [1] Delft, April 2011, overview of Electric Vehicles on the market and in development
- [2] Volume 1 (2014) 247-251 ISSN 2347 – 3258, International Journal of Advance Research and Innovation, Design of Electric Bike with Higher Efficiency.
- [3] Consoli A, "Propulsion Drives for Light Electric Vehicles." International Conference Electrical Machines (ICEM.'94), Conference Proceedings, Paris, Sept. 1994.
- [4] Bhandari V B. Design of machine elements. New York: Tata McGraw-Hill; 1994.
- [5] Carlson H. Spring designer's handbook. New York: Marcel Dekker Inc.; 1978.
- [6] Shigley J. Mechanical engineering design. New York: McGraw-Hill; 1981.
- [7] R.S. Khurmi & J.K Gupta (2003), "A textbook of machine design", 14ed. S.Chand & company publication, Ram Nagar, New Delhi 2006; 23; Page 820-884.
- [8] Richard G. Budynas, J. Keith Nisbett "Shigley's Mechanical Engineering Design" 10ed, Tata Mc-Graw-Hill Publishing Company Ltd, 2 Penn Plaza, New-York, 2015; 1; page 85-273; 509-561.
- [9] Nitin S Gokhale, Sanjay S Deshpande, Sanjeev V Bedekar, Anand N Thite. "Practical Finite Element Analysis" 1st edition, Finite to Infinite, Pune. 2008, 4; page: 35-111; 175-187.
- [10] Adam G. Rasbach, Orion, MI (US). "United States Patent, Application. Publication" Pub. NO. US 2013/0127101 A1 Rasbach (43) Pub. Date: May 23 2013.



10.22214/IJRASET



45.98



IMPACT FACTOR:
7.129



IMPACT FACTOR:
7.429



INTERNATIONAL JOURNAL FOR RESEARCH

IN APPLIED SCIENCE & ENGINEERING TECHNOLOGY

Call : 08813907089  (24*7 Support on Whatsapp)