



IJRASET

International Journal For Research in
Applied Science and Engineering Technology



INTERNATIONAL JOURNAL FOR RESEARCH

IN APPLIED SCIENCE & ENGINEERING TECHNOLOGY

Volume: 7 Issue: V Month of publication: May 2019

DOI: <https://doi.org/10.22214/ijraset.2019.5217>

www.ijraset.com

Call:  08813907089

E-mail ID: ijraset@gmail.com

Arduino Based Smart Stove

Manjusha K V¹, Konjath Parvathi², Neenu Johnson³, Richard Joy⁴

^{1, 2, 3, 4}Sahrdaya College of Engineering & Technology, Kodakara, Kerala, India

Abstract: Basically, a smart stove is a modification given to our traditional stove. So that we don't need to manually control the stove, it will automatically switch off, after the time we set it. We have attached a mechanical gear to the stove, then this gear is driven with a step up motor. This motor is driven or controlled by a motor driver and an Arduino UNO. The microcontroller is programmed to control the motor according to the time set by the user. Now the ON and OFF or the time can be set by the input buttons provided. Multitasking is possible for the house makers by implementing this project. It also saves fuel by the timely use of gas by this device. In the present scenario, there is the day to day instances of which the food getting overcooked or getting spoiled due to overheating that happens as a result of the carelessness of the people in charge. This may cause a loss of fuel. The problem worsens when the delay occurs with people in realizing that the gas is turned on, and this can even lead to accidents. The damaging of food and the related wastage of fuel and time can be tackled with the smart stove technology. The stove features an automatic turn off mechanism, where the problems addressed above can be overcome. The stove is internally equipped with Arduino and gears that facilitate the automatic turn off mechanism. The design is economical and is a better solution to the problems faced by the house makers.

Keywords: Stove, Arduino UNO, Motor driver, Mechanical gear

I. INTRODUCTION

In 2013, just 44 percent of households cooked dinner 2 to 5 times a week. This made us think, improving upon the stove's technology for the everyday cook would

Ultimately help people cook better food. Instead of simply making a stove more convenient, we set out to overhaul the entire cooking experience and make it easier and more fun for everyone. We talked to regular Joes who cook at home, and some professional chefs, too, to discover what one experiences when they cook. So in this project, we introduce an Arduino based smart stove. Basically, a smart stove is a modification given to our traditional stove. So that we don't need to manually control the stove, it will automatically switch off, after the time we set it. It will help the homemakers a lot, because even if they forget to switch off the stove, no need of worry so that our smart stove will switch the knob in off position after the set time. In the present scenario, most of us face difficulties due to lack of time, especially women. Most of the homemakers have come across the situation where the food items getting spoiled while cooking due to carelessness and due to other factors. Some times we often forget to switch off the stove knob while we engage in other activities. Then there is a chance of spoiling the food due to overcooking. We have found a simple and cheaper technology for solving that problem by incorporating our simple device in the stove knob. This device helps in regular cooking activities by setting the time in the device. And it reduces manual supervision and human effort with simple circuitry. Automatically the stove's knob will switch off after the set time so that it reduces the chances of spoiling food items during cooking and also saves fuel by avoiding overcooking. This project makes use of simple electronic devices that are cost effective and affordable for an average homemaker. The mechanical gear attached to the stove knob and the motor that controls the gear, based on Arduino plays a major role in the action of this project. As it is very easy to use and cheap, it can be marketed as an efficient solution. This project will be definitely a boon to all the homemakers.

II. LITERATURE REVIEW

From the day of its origin, the gas stoves have undergone drastic transformation and reached to a model that totally lowered the workload of women. Centuries past, saw people cooking in open fires and braziers. The mornings witnessed women collecting woods from distant places, which gradually turned out to be their morning routine. The earliest stove designs could be traced back to the Chinese Qin dynasty (221BC-206/207 BC), the women at those times used the clay stoves, whose design were known as kamado

[2]. These stoves were fired by wood or charcoal through a hole in the front. Open fire systems were prevalent cooking styles in Europe, were visible only before the eighteenth century. These had the disadvantages of having low efficiency, producing a large amount of smoke. In addition, these methods had a lot of risk factors. Problems faced gradually paved the way for evolutionary series

of improvements, from 16th century onwards. As an improvement, fire chamber was introduced. The fire is enclosed on three sides by mortar and brick walls and covered by an iron plate [1]. This new method also caused a change in kitchen hardware. The fire enclosed model was named the Castrol stove, and it was designed by a French architect Francois de Cuvillies [3]. A stove with a built in cook top is known as a range [1]. The invention of modern cooking range accounts back to 1790s, by Sir Benjamin Thompson. He put the study of heat on a scientific basis and developed improvements for chimneys, fireplaces and industrial furnaces, which eventually led to his invention of kitchen range. The idea of restricting the chimney opening to increase the up draught, created a huge sensation in London. The method was considered to be the efficient means for heating a room than earlier fireplaces. Many more improvements in fire places were created, such as inserting bricks into hearth, in order to keep the side walls in an angled position and adding a choke to the chimney to increase the speed of air going up the flue

The efforts basically resulted in a streamlined flow of air through the chimney, rather than causing it to spread inside the room. Increased efficiency and control over the rate of combustion of fuel were the other major important effects. Thomson's cooking

range however caused less impact on domestic cooking. The beginning of nineteenth century saw steady improvements in stove design. The key aspect was that, cast irons replaced masonry and their sizes were reduced in a manner that could fit in domestic kitchen. The prominent design of incorporating baking facility along with stove, received patents in the year 1867 for Elizabeth Hawks in New York. Stoves of those times burned charcoal as well as wood. The stove was typically characterized with flat tops, and it was known as the piano system. The style of cooking was followed by French chefs even after gas replaced wood or charcoal. With the advent of fuel technology, availability of gas at cheaper rates introduced the pipelined stove networks [4]. This was however replaced by electric stoves with the electric power widely available and economically viable. The electric stoves were slow to catch fire compared to gas stoves. There were many other problems regarding with electric stoves such as limited power availability from the electrical supply company, poor temperature regulation and short life of the heating elements. The invention of nichrome alloy however provided an alternative solution to the problem of shorter lifespan of heating elements [5]. The fuels used in gas stoves are non-renewable energy sources. Either of the following combustible gases such as syngas, natural gas, propane, butane, liquefied petroleum gas or other flammable gases is used.

III. SYSTEM DESIGN

We have designed this product in such a way that it is applicable to all the traditional stoves. Since all the traditional stoves work with a manual knob mechanism. We made use of this knob to control the stove in a smart way. We have put together a gear assembly to the knob so that it can be connected to the DC motor later. This is a high torque 60 rpm motor, which is driven by the motor driver IC L293D which is then controlled by the control signal from the microcontroller ie Arduino UNO. The time details will be displayed in the LCD screen.

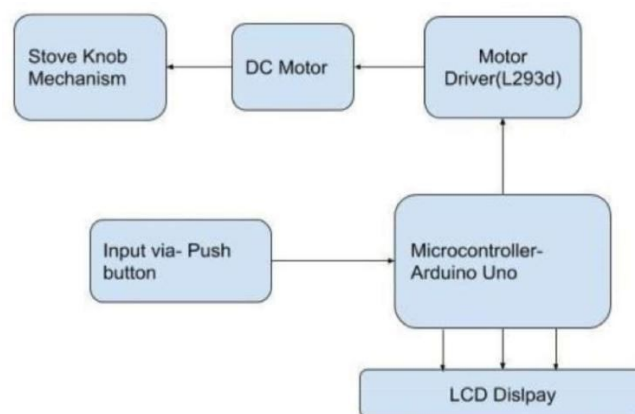

Figure 1. Block Diagram

The stove's knob is connected with the DC motor and

Here we use IC L293d motor driver for controlling the DC motor. Arduino UNO microcontroller is here used to control the motor driver. Push buttons are used to give inputs externally. LCD display is used for monitoring the timing.

IV. COMPONENTS

1) *Arduino Uno*: The Arduino UNO is an open-source microcontroller board based on the Microchip ATmega328P microcontroller and developed by Arduino. The board is equipped with sets of digital and analog input/output (I/O) pins that may be interfaced to various expansion boards (shields) and other circuits. The board has 14 Digital pins, 6 Analog pins, and programmable with the Arduino IDE (Integrated Development Environment) via a type B USB cable. It can be powered by a USB cable or by an external 9 volt battery, though it accepts voltages between 7 and 20 volts. It is also similar to the Arduino Nano and Leonardo. The hardware reference design is distributed under a Creative Commons Attribution Share-Alike 2.5 license and is available on the Arduino website. Layout and production files for some versions of the hardware are also available. "Uno" means one in Italian and was chosen to mark the release of Arduino Software (IDE) 1.0. The Uno board and version 1.0 of Arduino Software (IDE) were the reference versions of Arduino, now evolved to newer releases. The Uno board is the first in a series of USB Arduino boards, and the reference model for the Arduino platform. The ATmega328 on the Arduino Uno comes preprogrammed with a boot loader that allows uploading new code to it without the use of an external hardware programmer. It communicates using the original STK500 protocol. The Uno also differs from all preceding boards in that it does not use the FTDI

USB-to-serial driver chip. Instead, it uses the Atmega16U2 (Atmega8U2 up to version R2) programmed as a USB-to-serial converter.



Figure 2. Arduino UNO

2) *Motor Driver IC L293D*: It is a typical Motor driver or Motor Driver IC which allows DC motor to drive on either direction. L293D is a 16-pin IC which can control a set of two DC motors simultaneously in any direction. It means that you can control two DC motor with a single L293D IC. It works on the concept of H-bridge. H-bridge is a circuit which allows the voltage to be flown in either direction. As you know voltage need to change its direction for being able to rotate the motor in clockwise or anticlockwise direction, Hence H-bridge IC are ideal for driving a DC motor. In a single L293D chip there are two h-Bridge circuit inside the IC which can rotate two dc motor independently. Due its size it is very much used in robotic application for controlling DC motors. There are two Enable pins on l293d. Pin 1 and pin 9, for being able to drive the motor, the pin 1 and 9 need to be high. For driving the motor with left H-bridge you need to enable pin 1 to high. And for right H-Bridge you need to make the pin 9 to high. If anyone of the either pin1 or pin9 goes low then the motor in the corresponding section will suspend working. It's like a switch.



Figure 3. ICL293D

3) *LCD Display*: A liquid-crystal display (LCD) is a flat-panel display or other electronically modulated optical device that uses the light-modulating properties of liquid crystals. Liquid crystals do not emit light directly, instead using a backlight or reflector to produce images in color or monochrome. LCDs are available to display arbitrary images (as in a general-purpose computer display) or fixed images with low information content, which can be displayed or hidden, such as preset words, digits, and seven segment displays, as in a digital clock. They use the same basic technology, except that arbitrary images are made up of a large number of small pixels, while other displays have larger elements. LCDs are used in a wide range of applications including LCD televisions, computer monitors, instrument panels, aircraft cockpit displays, and indoor and outdoor signage. Small LCD screens are common in portable consumer devices such as digital cameras, watches, calculators, and mobile telephones, including smartphones.

V. SYSTEM WORKING

We have attached a mechanical gear to the stove, then this gear is driven with a step up motor. This motor is driven or controlled by a motor driver ICL293D and Arduino UNO microcontroller is used to process motor driver ICL293D. We can provide required time as input through the buttons provided. The microprocessor is coded in such a way that the mechanical gear allow the stove knob to switch off, as it meets the required time that we have setted in it. As the motor driver controls the mechanical gear, easily the stove knob will switch off. Through the LCD screen provided, we can monitor the time.

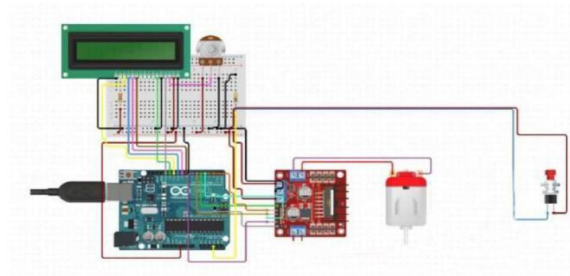

Figure 4. Connection Diagram

VI. RESULTS

By the end of the project, a successful working prototype was made. The ARDUINO BASED SMART STOVE was developed by using an Arduino UNO, L293D motor driver IC, DC motor and a gear. This is absolutely a low cost project, which is implemented with some modifications in the existing stove. At a time it is an advancement in technology and also cost effective. The smart stove can be effectively used in our kitchen and it is simple, user-friendly and can be installed very easily. This project will be a boon for all the homemakers. Finally the prototype was made successfully with the help of Arduino UNO, DC motors and drivers. And we successfully implemented the circuit.



Figure 5. Implemented Circuit

VII. FUTURE SCOPE AND CONCLUSION

Automatic gas stoves provides a lot of benefits to the homemakers. The increased job opportunities for women and busy time schedules especially for the working women, highlights the need for automation in their day to day activities. The smart stove will be providing a better solution of safe and efficient cooking. The facility of setting time beforehand is a feature that already exists in induction cook tops. The gas supply is provided during the allotted time, whenever it crosses the time limit, the connection of supply towards the stove is cut. The increasing pressure on non-renewable resources is a fact that haunts nationwide environmentalists. The scope for renewable cooking fuels such as biogas, methane, etc and those concepts that are still under the research topics of the scientists can be expected to replace the existing fuel methodologies.

VIII. ACKNOWLEDGEMENT

We take this opportunity to thank God Almighty for showering his blessings upon us, without which this Project would have ever seen light. Our heart is filled with gratitude for all those who have helped us. We are obliged to and grateful to our parents whose encouragement and support helped us to make this project a success. We show our sincere gratitude to all our group mates. At last, we once again extend our sincere gratitude to one and all, who contributed to this design project in one way or the other.



REFERENCE

- [1] Sai Bhaskar N. Reddy. Understanding Stoves For Environment and Humanity. The Netherlands: MetaMeta, 2012. E-book.
- [2] Global Alliance For Clean Cook stoves. Handbook for Biomass Cook stove Research, Design, And Development, A Practical guide to implementing recent advances. United Kingdom: UK aid. Handbook
- [3] Niklas Vahlne, Chalmers University of Technology, Department of Energy and Environment, division of energy technology; 2013; Policy Implications For Improved Cook stove Programs- A Case study of the Importance of Village Fuel Use Variations; <https://doi.org/10.1016/j.enpol.2013.11.042>.
- [4] Practical Action-Improved Cooking Stoves; <https://practicalaction.org/improved-cooking-stoves>
- [5] Amanda Leigh Haag; 2008; Stove for the Developing World's Health; <https://www.nytimes.com/2008/01/22/science/22stov.html>.



10.22214/IJRASET



45.98



IMPACT FACTOR:
7.129



IMPACT FACTOR:
7.429



INTERNATIONAL JOURNAL FOR RESEARCH

IN APPLIED SCIENCE & ENGINEERING TECHNOLOGY

Call : 08813907089  (24*7 Support on Whatsapp)