



iJRASET

International Journal For Research in
Applied Science and Engineering Technology



INTERNATIONAL JOURNAL FOR RESEARCH

IN APPLIED SCIENCE & ENGINEERING TECHNOLOGY

Volume: 7 Issue: V Month of publication: May 2019

DOI: <https://doi.org/10.22214/ijraset.2019.5311>

www.ijraset.com

Call:  08813907089

E-mail ID: ijraset@gmail.com

E-Andharakolu

M S Shobha¹, Rajshekhar Hotti², Kavya³, Kiran⁴, Vishrutha⁵

¹Senior Assistant Professor, ^{2,3,4,5}Department of Information Science Engineering
New Horizon College of Engineering, Outer Ring Road, Marathalli, Bengaluru- 560 103

Abstract: As age of human beings increase most of the people lose their eye sight nowadays, they face more problems in their daily routine life. One such example are persons with low visibility, who cannot operate mobiles in the emergency conditions whenever they need help from required persons, (requirement of doctor). Aged people with blindness find problem while walking, such as unable to view obstacle at a close distance in front of them which may inflict injuries to one-self. To overcome these such problems faced by low sight by old aged people, we have come up with solution which helps them to walk freely and fulfill their requirements using speech reorganization and intimate to the person by text message with the area where the patient is, and calling to specifies persons. This project informs the user through voice about the distance of a particular object ahead them through voice output. Along with this another feature is also added such as sensing the lighting condition in the room and illuminating an LED lamp automatically.

Keywords: Video Classification, Convolutional neural network, machine Learning, Smartstick, Microcontroller.

I. Introduction

This project aims at providing a proper navigation for individuals suffering from blurred vision and blindness, which happens due ageing factor. Many embedded systems have substantially different designs, structured modular design concept is adopted and the system is mainly composed of a Renesas microcontroller, LDR, LED driver, LED lamp, Ultrasonic sensor (HCSR04) and Bluetooth. An application created and stored in the Android based Smartphone, generates speech output depending upon the incoming messages transmitted via Bluetooth.

This paper proposes the design and development of an e-Andharakolu that helps the visually impaired people.

II. LITERATURE SURVEY

1) *Paper [1] Title:* Blind stick is an innovative stick designed for visually disabled people for improved navigation.

This system uses ultrasonic sensor along with light and water sensing. The microcontroller used processes the data collected by the sensor and calculates whether the obstacle is close enough for the circuit to send a signal to the buzzer in order to produce the sound that indicates to the blind person about the obstacle. The system also sends out differently sounding buzzer when it detects water. Another add-on of this project is that allows the user to detect if the room that they enter is dark or there is sufficient light. The special feature of this system is that it helps the blind to find the blind stick if in case they loose it or also if they forgot where they left it which is implemented using a wireless RF based remote.

2) *Paper [2] Title:* A smart stick system for assisting blind people.

The system used here is designed to act like an artificial vision and alarm unit. This system contains five different sensors, which are an ultrasonic sensor, an IR sensor, a water sensor, a fire sensor and a light (LDR) sensor. The microcontroller (Arduino Uno R3) is used to receive the signals sent by the sensors and process those signals to short pulses that will be inputs to the Arduino pins where voice alarms, buzzers and vibrators are connected to. The system also uses GPS navigation that is separately in the mobile which is used to guide and help the blind user to reach or find new or unfamiliar places.

3) *Paper [3] Title:* Smart Stick for Blind People

This system uses ultrasonic sensors to detect objects that are being approached by the blind. Since there are chances that they might get lost or are in a place where they are finding it difficult to get back home or to some familiar place, the system uses GPS and GSM modules to find the location

In order to help the blind people for detecting object the proposed system make use of ultrasonic sensors to track the person. The system makes use of GPS and GSM modules to find the location. These modules are very useful since their family members will be able to track them very easily.

4) *Paper [4] Title:* An Intelligent Walking Stick for the Visually-Impaired People.

This system uses GPS and ultrasonic sensors to detect any obstacle and provide accurate location. The system uses four sensors with different attributes. All these four sensors are placed in such a way that two sensors are implemented at the front, one on the left and the other on the right, which will calculate distance and then send it to the Arduino module. After which the Arduino module will transmit the accurate distance to the application on the smartphone through the additional Bluetooth module used. Through the smartphone application the blind user will be able to hear the instruction through his/her headphone.

III. PROBLEM STATEMENT

The e-Andharakolu is an embedded system integrating the following : pair of ultrasonic sensor to detect obstacles in front of the blind from ground level height to head level height of the stick in the range of 400 cm ahead, infrared sensor to detect upward and downward stairs, Bluetooth HC05 to connect to the android application on the smartphone, a moisture sensor to detect water presence and also an RFID sensor. The sensors collect the real-time data and send it to the microcontroller for processing. After processing, the microcontroller invokes the right speech warning message through a Bluetooth earphone. The system is powered by a rechargeable battery. The GPS based blind device with user input interfacing get alert to the blind person when he reaches his destination by voice. This consists of microcontroller module, GPS Unit and a voice module to generate voice output.

IV. METHODOLOGY

Many embedded systems have substantially different designs according to their functions and utilities. In this project design, structured modular design concept is adopted and the system is mainly composed of a Renesas microcontroller, LDR, LED driver, LED lamp, Ultrasonic sensor (HCSR04) and Bluetooth. The microcontroller located at the center of the block diagram forms the control unit of the entire project. Once the entire unit (comprising of microcontroller and sensors) is worn by the patient the sensors begin to monitor the surrounding environment conditions .In this case the ultrasonic sensor and LDR form the input to the microcontroller. Based upon the program embedded within the controller an output is generated and transmitted to the Android based Smartphone via Bluetooth module. An application created and stored in the Android based Smartphone, generates speech output depending upon the incoming messages transmitted via Bluetooth. Ultrasonic sensor is utilized to locate the distance of any object from the person. The sensor on detecting the presence of the obstacle delivers an input voltage to the microcontroller which then alerts the patient via Android Smartphone through the use of Bluetooth module.

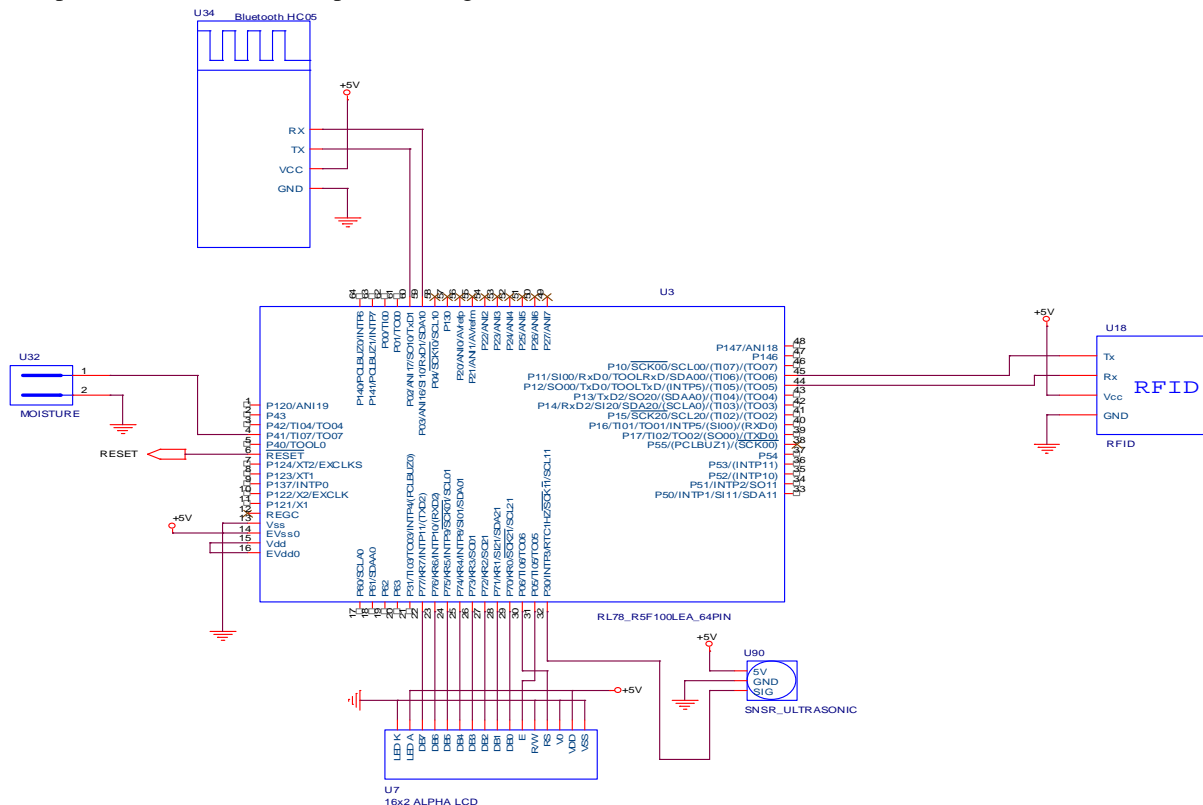

Fig: Overall Schema Of the Smart Blind Stick



V. RESULT AND CONCLUSION

The main purpose of this project is to produce a prototype that can help the blind by detecting obstacles in front of the user and feeds warning back in the form of voice messages. The developed prototype gives good results in detecting obstacles paced at distance in front of the user and also the obstacles.

REFERENCES

- [1] Implementation and Design of Smart Blind Stick for Obstacle Detection and Navigation System K.S.Manikanta, T. S. S. Phani, A .Pravin3 M.Tech Student, Associate Professor, Professor Department of Electronics & Communication Engineering BVC Engineering College, Odalarevu, India
- [2] A Smart Stick for Assisting Blind People Ashraf Anwar1, Sultan Aljahdali2 1,2Faculty of Computers and Information Technology, Taif University, P.O. Box 888, 21974 Taif, Saudi Arabia
- [3] Smart Stick for Blind People Manikandan Shanmugam, John Victor, Mayank Gupta and K. Saravanakumar, IV MCA, Associate Professor, Department of Computer Science, Christ University, Bangalore, India
- [4] An Intelligent Walking Stick for the Visually-Impaired People Nadia Nowshin, Sakib Shadman, Saha Joy, Sarker Aninda, Islam Md Minhajul American International University-Bangladesh (AIUB), Dhaka, Bangladesh
- [5] SMART BLIND STICK USING ARDUINO R.Dhanuja, F.Farhana, G.Savitha UG Student, Department of electronics and communication engineering, Jeppiaar SRR Engineering College, Tamil Nadu, India Assistant Professor, Department of electronics and communication engineering, Jeppiaar SRR Engineering College, Tamil Nadu, India



10.22214/IJRASET



45.98



IMPACT FACTOR:
7.129



IMPACT FACTOR:
7.429



INTERNATIONAL JOURNAL FOR RESEARCH

IN APPLIED SCIENCE & ENGINEERING TECHNOLOGY

Call : 08813907089  (24*7 Support on Whatsapp)