



IJRASET

International Journal For Research in
Applied Science and Engineering Technology



INTERNATIONAL JOURNAL FOR RESEARCH

IN APPLIED SCIENCE & ENGINEERING TECHNOLOGY

Volume: 7 Issue: V Month of publication: May 2019

DOI: <https://doi.org/10.22214/ijraset.2019.5300>

www.ijraset.com

Call:  08813907089

E-mail ID: ijraset@gmail.com

Low Voltages Wireless Transmission for indoor Applications

Femi-Jemilohun O. J¹, Ismail I², Uwaezuoke E²

^{1, 2}Department of Electrical and Electronic Engineering Ekiti State University, Ado Ekiti Ekiti State, Nigeria

³Department of Electrical and Electronic Engineering, Afe Babalola University, Ado Ekiti, Ekiti State Nigeria

Abstract: *The advancement in the semiconductor industry has enabled the emergence of great potentials in wireless communication applications in all fields of endeavours. Wireless power transmission is benefiting from this new technology: being inexpensive, ubiquitous and easy to access, is gaining high acceptability in the recent times. The focus of this research was to design and implement a wireless power transmission link for indoor use, using an inductive coupling technique. The designed devices were tested and found capable of charging electronic devices with DC power supply in the range of 5V DC and 0-25cm distance coverage. The results of the experiments carried out to verify the functionality of the constructed device with its high efficiency were presented.*

Keywords: *Low voltage, wireless transmission, wired transmission, power loss, seamless transmission.*

I. INTRODUCTION

The fast growth experienced in communication industry in the recent times as a result of advancement in Semiconductor technology has propelled a rapid emergence of wide variety of portable consumer electronic devices, medical and industrial devices. All these required regular charging for effective operation, users are still bound by the era of wired power transmission for charging their devices when need arises. This has kept them immobile for the period and may cut of use when the soled battery is depleted and power outlet is not in view [1].

The generation, transmission and distribution of electric power in Nigeria are based on wired networks across the country. It was reported by [2] that between the power generation networks and end users, power loss of about 26-30% as a result resistance of the wire is incurred. Hence the efficiency of the power generation, transmission and distribution is between 70-74%. The current flow generates heat which leads to temperature rise and consequently further increase the resistance of the cables and invariably, the power loss [3].

A. Power Losses in Wired Power Transmission

The Magnetic field of the current carrying inductor generates an electric current in its windings. The charging and the discharging of the capacitor causes the supplied current to build up magnetic field around the conductor, this leads to resonance of the current. This process is represented mathematically according to [4] by the following equations:

$$\text{Resonance Frequency (Fr)} = Fr = \frac{1}{2\pi\sqrt{LC}} \quad (1)$$

$$\text{Quality factor (Q) is given as: } Q = \frac{XL}{R} = \frac{2\pi FrL}{R} \quad (2)$$

$$\text{Coupling factor is given as: } k = \frac{L_{12}}{\sqrt{L_{11}L_{22}}} \quad (3)$$

But

$$\frac{U_2}{j.w} = L_{12} \cdot I_1 + L_{22} \cdot I_2 \frac{U_1}{j.w} = L_{11} \cdot I_1 + L_{12} \cdot I_2 \quad (4)$$

$$U = \frac{U_2}{U_1} = k \sqrt{\frac{L_2}{L_1}} \quad (5)$$

The magnetic field produced by a current carrying wire according to Biot-Savart Law is given by;

$$B = -\frac{\mu_0}{4\pi} \oint_l \frac{L I d_l \times e_r}{r^2} \quad (6)$$

For a circular coil, the flux density at a point x is given by;

$$B_x = \frac{\mu_0 N I a^2}{2(a^2 + x^2)^{\frac{3}{2}}} e_x \quad (7)$$

Here, N is the number of turns, I is the current in each turn, a is the radius of the circular coil, x is the distance from the centre of the coil to point x and e_x is the unit vector of distance between point x and a

The total magnetic flux at secondary coil is given as;

$$\Phi_m = \int B \cdot d_s \tag{8}$$

Where S is the surface area of the secondary coil. The induced voltage in the secondary coil according to Faraday’s Law is given as;

$$V(t) = -\frac{d\Phi_m(t)}{dt} \tag{9}$$

$\Phi_m(t)$ is the total varying magnetic flux across the second coil.

Losses incur during power transmission results in energy wastage which produces heat. Attempt to reduce this loss will improve the efficiency of the system. This losses can be reduced by the following mathematical expression:

$$\lambda_{min} = \frac{2}{(kQ)^2} \left(1 + \sqrt{1 + (kQ)^2} \right) \tag{10}$$

The state-of-art technology such as Wireless Power Transmission (WPT) can salvage this situation, if the power sector can adopt this system at all levels of their system networks. This will increase the revenue generation, and add aesthesis to their service because the ugly sight of cables dangling, wire burnt and poles damage will be prevented for the long range transmission. Likewise, the clumsy scenarios in the homes and offices as a result of wire connection for various appliances and devices will be eradicated if WPT is adopted for short range power deployment. Wireless power transfer is a new and emerging technology where electrical energy is transferred from the distribution point to loads and appliances through the air space without connection to cables and wires [2]. Wireless power transmission becomes imperative in situations where steady power supply is required and drawing of wire for electrical connection is highly prohibited due to dangers, inconvenience health hazards such tend to pose in such environments, hence the conventional method of power transfer is forbidden. The emergence of this technology heralded by the advance and ubiquity in semiconductor technology is making a huge wave of transformation in the electrical engineering domain and the power sector globally [5]. The proliferation of wireless and ubiquity in telecommunication industry is affecting the lifestyle globally. This tremendous change has impacted virtually every field of profession and organization now, power sector cannot therefore afford to be left behind, It is time this sector goes wireless in their networks systems [6].

B. Wireless Power Transmission Technology

Communication technologies are providing ubiquitous, myriad and cable free communication devices to the users but users’ devices are still battery dependent and limited hence need wires connection to the source of power supply to charge them. The recent advances in technologies promise to charge devices without the help of wires and cables [7]. This is achieved by employing the wireless power transfer approach. There are three basic ways to achieve WPT depending on the coverage: Inductive coupling, resonant induction and electromagnetic wave propagation. Each of these techniques has different coverage distances: the induction coupling is used for short range applications, the resonant induction is for mid-range while electromagnetic wave is used for long range propagation. Power transmission through radio waves can be made more directional, allowing longer-distance power beaming, with shorter wavelengths of electromagnetic radiation, typically in the microwave range. Wireless power transmission being an effective and efficient way of electrical energy transmission can be adopted for the distribution of electricity in places where the conventional way of wire drawing is difficult and not feasible [2]. Fig 1 depicts these different modes of wireless power transmission techniques.

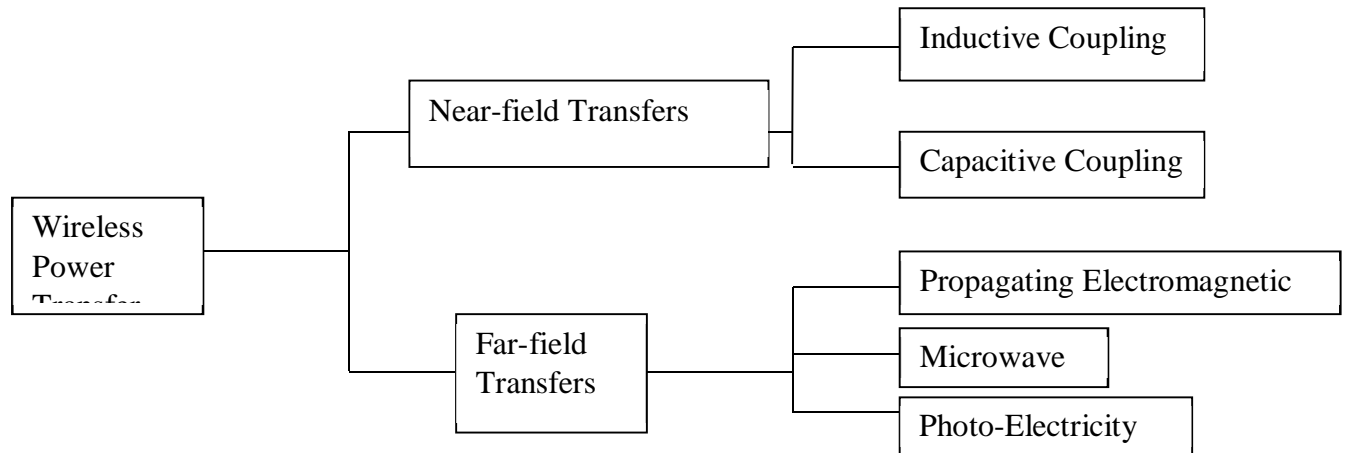

Fig1: Techniques of Wireless Power Transmission [8]

C. Wired versus Wireless Power Transmission

The conventional way of electrical power transmission is by means of wires and cables. This method presents a clumsy, clustered and messy scenarios as the increase in appliances in the homes and offices create a complex connection [2,9], a better way of energy transfer through air space will save this stress. Fig 2 shows a wired connection in a typical home and office scenario. The tangling and the twisting of cables may result in wire cut and pose danger of electric shocks to the consumers.

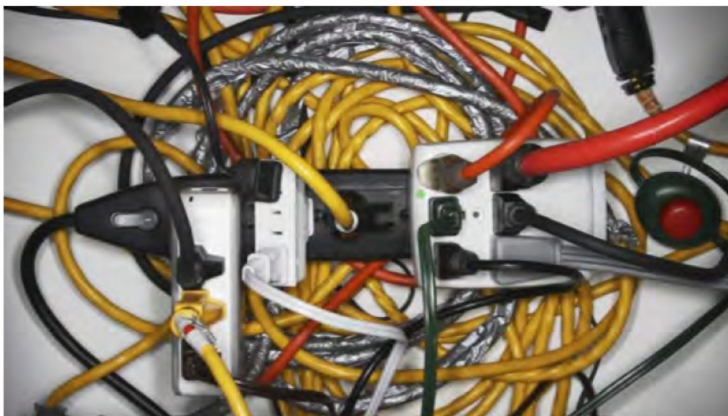

Fig 2: Wired Power Transmission Environment [9]

Wireless power transfer on the other hand, is a clean and safe way of electrical energy transfer. The interaction of the magnetic waves with humans and other living things has been found to be mild, hence deployment of electricity through this means has been scientifically proven to be safe the livings. The effectiveness of WPT is directly proportional to the separation of the transmission links. The frequency of deployment of WPT is not hamper by walls and other barriers, WPT can penetrate through walls and any obstruction on its path of propagation [5]. Fig 3 depicts a typical environment where wireless power transmission is employed to power all the appliances in the home and offices.

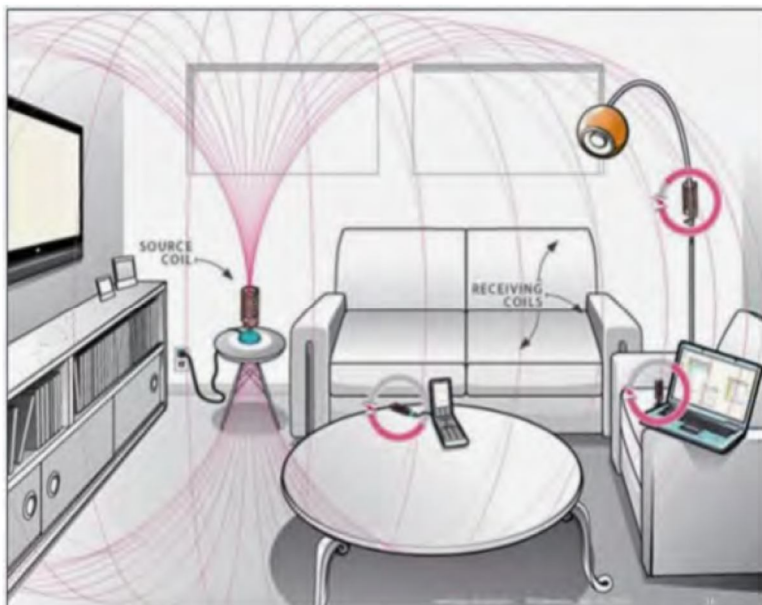

Fig 3: Wireless Power Transmission Environment [8]

The electrical power network based on wired transmission is a complex one, a way out of this complication is to embrace the WPT technology at all levels of power supply [9,2]. The reality of WPT has come to stay with us, being a non-radiative energy propagation, it is environment friendly and highly economical, void of capital intensity required by power grid to install wires and cables, towers, substations across the country and within residential. The challenge of signal interference is avoided in WPT, little or no loss can be traced to the network deployed on WPT, it is about 90-97% efficient as well as ubiquitous in nature [6]

II. REVIEW OF RELATED WORK

The emergence of WPT provides an ubiquitous, cable connection free charging facility for the electronic devices on the go and within homes and offices. The craving to use wireless power connection in place of all wired energy transmission is increasing by the day [1]. Some of the distinguishing features of the WPT from the existing means of power transmission are its low maintenance cost, it is very cheap and efficient. WPT is eco-friendly and reliable, and therefore desirable to users. Since the act of wire connection is totally eliminated, the clumsy site of wire connection and sagging power lines are eliminated thereby addressing the challenge of e-waste associated with wired transmission networks [6]. Though this technology is still in its infant stage, researchers and industry are focusing attention on this new technology in the recent times, some of the few works that have been carried out by some researchers are discussed. The design and implementation of wireless power transmission using magnetic induction was carried out by [2]. The comparison between the theoretical models and experimental measurement was also conducted. This author implemented a wireless power transmission for a residential use using the resonant coils for the transfer of power from the mains to different appliances such as fan, battery and LED. Another author considered WPT using inductive coupling technique and succeeded in transferring 6V across a distance of 20cm [6]. In [8] a design of WPT using Tesla coil was presented, Prototype model was designed that can supply 5 Watt bulb for the distance 10cm. In another work, the authors present a model of magnetically coupled resonators in terms of passive circuit elements and derive system optimization parameters [1]. This research work is a part of the extensive work that is ongoing in this new emerging area in the recent times.

III. METHODOLOGY

The block diagram of a wireless power transmission system is shown in Fig according to [5]. The circuit diagrams of [6, 7] were adapted and modified in this work. The hardware design of wireless charging system are divided into three sections: power supply section; transmitter section; and receiver section. The power supply section steps down 230v 50Hz to 12v 50Hz which is rectified and filtered for the oscillator circuit. Transmitter section consists of electronic parts that drives as push-pull driver (alternate power MOSFET transistors T1 and T2) to transfer magnetic field (inductive coupling) by passing the frequency oscillation about 1.67MHz. A very good and powerful regulated power supply is implemented by simply adding a PNP power transistor to the LM317T adjustable regulator chip. In this way this circuit can deliver much more than the power required in driving two MOSFET transistors to full output.

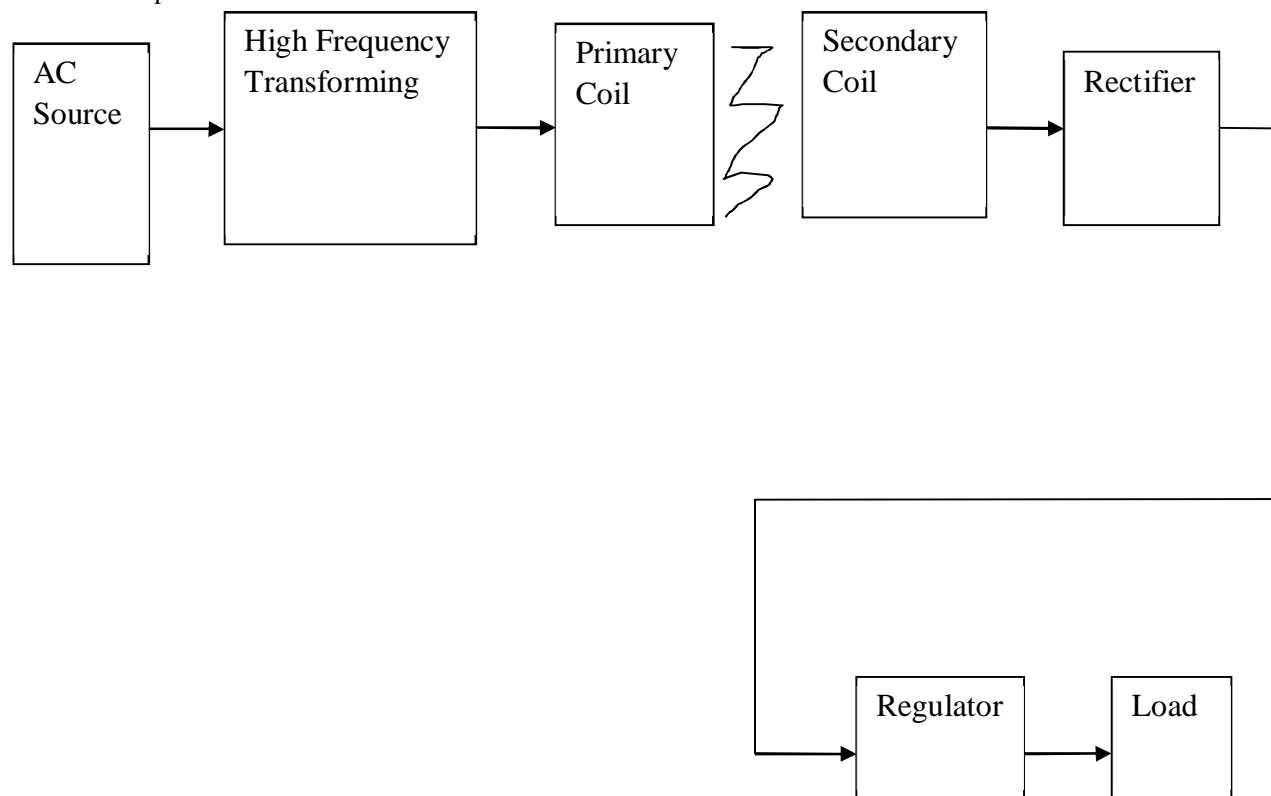

Fig 4: Block Diagram of a Wireless Power Transmission System [5]

The choice of some of the circuit parameters used are presented in Table 1

Table 1: Lists of Design components

Transformer	230V/15X2, 2A
555 timer	1
Variable resistor	1
Resistor (0.25W)	2, 330 ohm
Resistor (0.5W)	1, 100
Resistor (0.25W)	1kohm (2)
Capacitor (ceramic)	0.1uf (1)
Capacitor (ceramic)	100pf (4)
Capacitor (electrolytic)	470uf (2)
Capacitor (electrolytic)	2200uf (1)
Copper wire (17 gauge)	20 turns
Copper wire (17 gauge)	40 turns
IRF540N MOSFET	1
BD132 Transistor	1
Bridge Rectifier	1
7805 voltage Regulator	1
LM317 voltage Regulator	1
IN4007 Diode	2
LED	3

LM317 is the 3 pin series adjustable voltage regulator that provides output voltage ranging from 1.2V to 30V at 1.5 amps. The voltage regulator LM317 protects the circuit from overheating, Pot RV1 allows us to vary the output voltage in between 1.2V to 30V. The minimum output voltage of LM317 voltage regulator 1.2V.

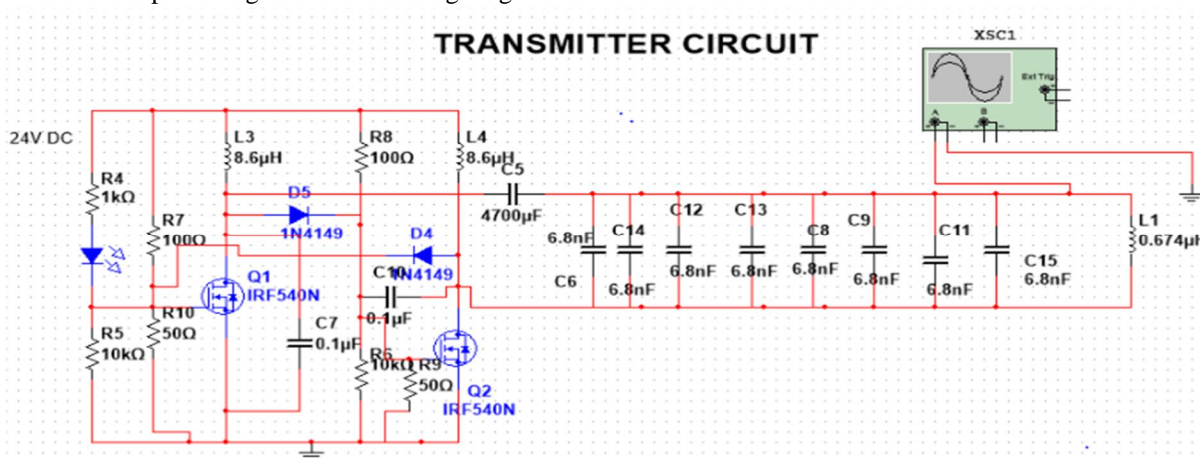

Fig 5: The Transmitter Circuit diagram of the Constructed WPT as adapted and modified from [6,7]

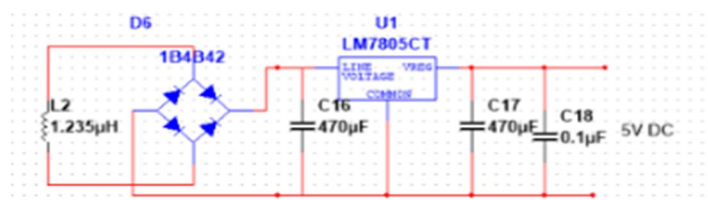

Fig 6: The Receiver Circuit diagram of the Constructed WPT as adapted and modified from [6,7]

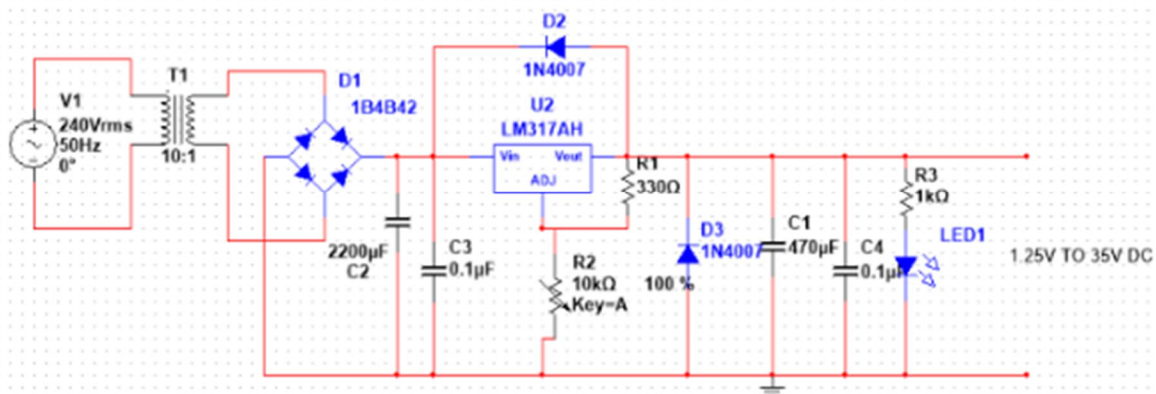

Fig 7: The Power Supply Unit Circuit diagram of the Constructed WPT as adapted and modified from [6, 7]



Fig 8: Construction Process of the Wireless Power Transmission System

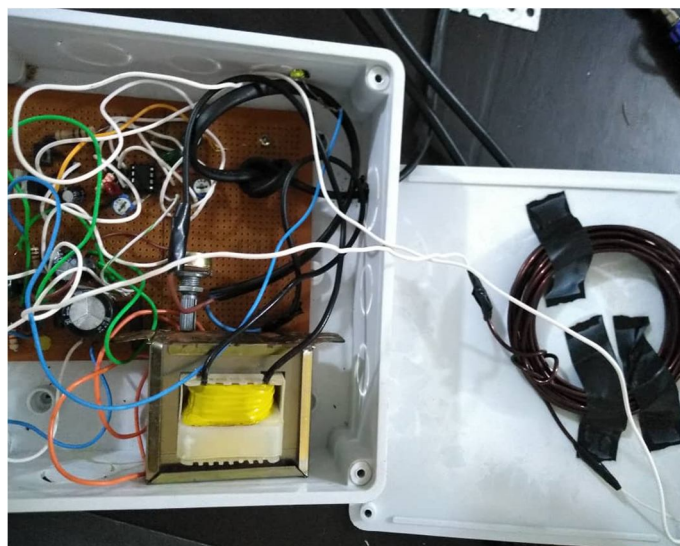

Fig 9: The Complete constructed Wireless Power Transmission System



Fig 10: Measurement of Voltage and current with the Constructed WPT Link

IV. RESULTS AND DISCUSSION

The designed and constructed wireless power transmission carried out in this research work was subjected to test to verify its workability and effectiveness. The measured values of current, voltage and power delivery capability of the device at transmitter and receiver ends with varying coverage distances are given in Tables 2 and 3 respectively. Table 4 depicts the calculated efficiency of the device at different distances covered. Fig 8 and 9 show the curves of the power delivery capability and the efficiency of the constructed device respectively. It is observed from the results that sufficient voltage is available to charge the electronic devices and appliances wirelessly in close proximity and to a distance of about 25cm away from the constructed device. Therefore the aim of wireless power transferred is achieved in this research to meet the need of end consumers in homes, offices and industries.

Table 2: Measurement of current, voltage and power at various distances at Transmitter

S/N	Distance(cm)	Current(mA)	Voltage(V)	Power(W)
1.	20	10.35	12.35	0.124
2.	18	10.95	12.35	0.135
3.	14	11.05	12.35	0.136
4.	10	12.13	12.35	0.149
5.	8	15.23	12.35	0.188
6.	4	18.51	12.35	0.228
7.	0	23.20	12.35	0.286

Table 3: Measurement of current, voltage and power at various distances at Receiver

S/N	Distance(cm)	Current(mA)	Voltage(V)	Power(mW)
1.	20	1.12	3.7	4.14
2.	18	1.44	4.2	6.05
3.	14	2.18	4.4	9.60
4.	10	2.32	4.5	10.4
5.	8	2.48	4.8	11.9
6.	4	3.09	4.9	15.1
7.	0	3.13	5.0	15.7

Table 4: The Calculated Efficiency of the system

S/N	Distance(cm)	Transmitter power(W)	Receiver power(mW)	Efficiency (Pout/Pin)x100
1.	20	0.124	4.14	0.051
2.	18	0.135	6.05	0.081
3.	14	0.136	9.60	0.131
4.	10	0.149	10.4	0.155
5.	8	0.188	11.9	0.224
6.	4	0.228	15.1	0.344
7.	0	0.286	15.7	0.449

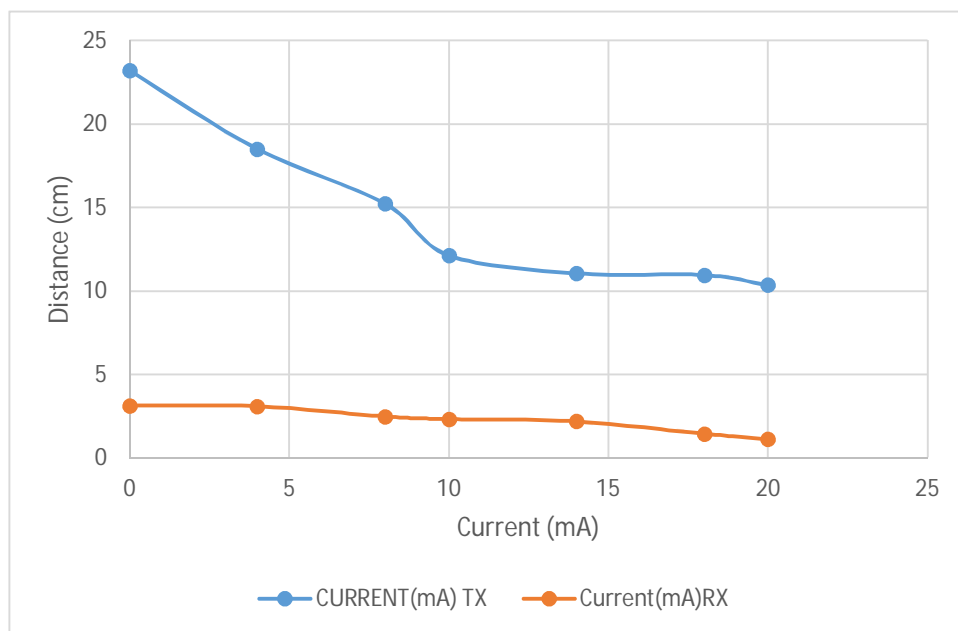

Fig 11: The transmitter and Receiver current capabilities at different range of distances

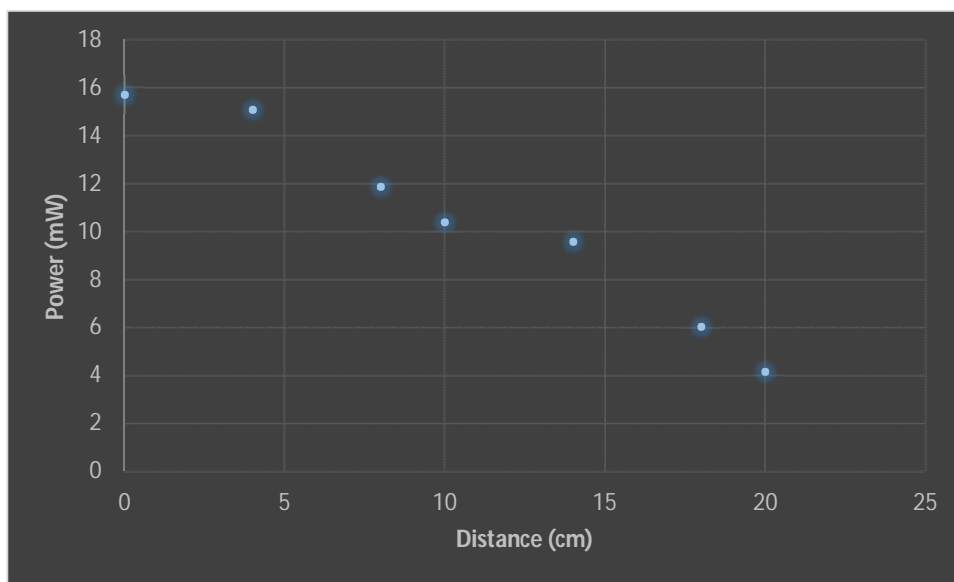

Fig 12: The power capability of the constructed link at different distances

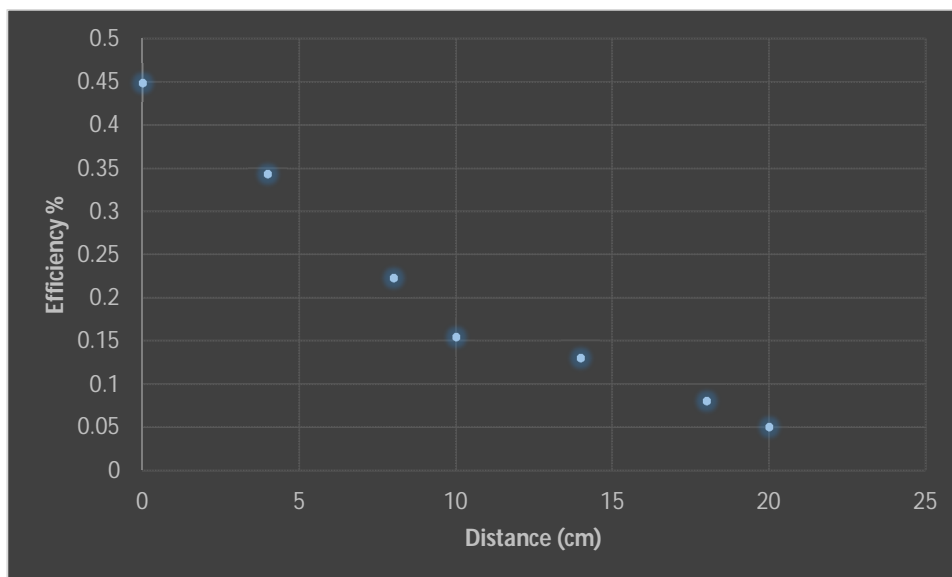

Fig 13: The Efficiency of the constructed link at different distances

V. CONCLUSION

A wireless power transmission link has been designed and constructed in this work. The test carried out with the system shows that sufficient power can be realised to charge the electronic devices and appliances in the homes and offices without going through the complex scenario pose by wired connection. It is also established in this work that the power losses and interference which characterized the wired connection will be eradicated if this technology of power transfer using air space is employed. This work therefore presents an alternative to consumer electronics as well as industry to tap into the advancement of semiconductor technology, rapid growth and proliferation in Telecommunication industry for a seamless, easy, clean, cheap and safe power transfer both in homes and offices.

REFERENCES

- [1] Borong H and Li R “High Efficiency with Multi Load Wireless Power Transmission” Index UDC: 621.3, 2014
- [2] Syed K.R, Omar A, Saiful I, Rafiul A, and Shariful I “Design and construction of wireless power transfer system using magnetic resonant coupling” American Journal of Electromagnetics and Applications . 2(2), 11-15 2014.
- [3] Femi-Jemilohun O.J “Wireless Power Transmission Approach for Electricity Leakages Minimization in the Nigeria Power Grid” International Journal of Engineering Research & Technology Vol. 8 Issue 05, 2019
- [4] John M “ Wireless Inductive Charging for Low Power Devices” Helsinki Metropolia University and Applied Sciences Thesis, 2017.
- [5] Meghana K, Divya G, Udaykumar K and Kunal P “Wireless Power Transfer (Electricity Out Of Thin Air)” Project in Jain College Of Engineering Belgaum
- [6] Mariya A.P, Gajendra A.N, Balaganesh R, Manikandan R and Saravanan J “Wireless Power Transmission Using Inductive Coupling” International Journal of Emerging Technology in Computer Science & Electronics (IJETCSE), Vol 8 Issue 1, 2014.
- [7] Tahsin K, Mahmudul A, Sajib Z and Dipta C Wireless Power Transfer Brac University, 2018
- [8] Wamalwa P W “Wireless Power Transmission” School of Engineering Department of Electrical University Of Nairobi, 2016.
- [9] Chavan P.L, Abhishek K, Rohini B, Priynka J, Ganesh P and Rahul J “Tesla Coil Wireless Power Transmission” International Journal of Scientific Research Engineering & Technology (IJSRET), Vol 7, Issue 3, 2018
- [10] Mohamed A. H, Elzawawi A “Wireless Power Transfer through Inductive Coupling” Recent Advances in Circuits, 2014.
- [11] Yin Q. T “Wireless Power Transmission in the SmartHome” Department of Electrical and Computer Engineering Duke University 2012
- [12] Daniel E .R “High Intensity Laser Power Beaming for WirelessPower Transmission” Cleveland State University, 2008
- [13] Christopher A.T “Transmission of Wireless Power by Magnetic Resonance” PhD Thesis, University of Reading, 2013
- [14] John M “Wireless Inductive Charging for Low Power Devices” Thesis in Helsinki Metropolia University of Applied Sciences ,2017.



10.22214/IJRASET



45.98



IMPACT FACTOR:
7.129



IMPACT FACTOR:
7.429



INTERNATIONAL JOURNAL FOR RESEARCH

IN APPLIED SCIENCE & ENGINEERING TECHNOLOGY

Call : 08813907089  (24*7 Support on Whatsapp)