



# **iJRASET**

International Journal For Research in  
Applied Science and Engineering Technology



---

# **INTERNATIONAL JOURNAL FOR RESEARCH**

IN APPLIED SCIENCE & ENGINEERING TECHNOLOGY

---

**Volume: 7      Issue: V      Month of publication: May 2019**

**DOI: <https://doi.org/10.22214/ijraset.2019.5263>**

**[www.ijraset.com](http://www.ijraset.com)**

**Call:  08813907089**

**E-mail ID: [ijraset@gmail.com](mailto:ijraset@gmail.com)**

# Studies on Wear and Bending Properties of AMMC's Reinforced with Bottom Ash

Raghavendra Karnool<sup>1</sup>, Kuntanahal Rajashekhar<sup>2</sup>, Harishbabu K<sup>3</sup>, Kedarnath H M<sup>4</sup>, Karthik M P<sup>5</sup>, Gopichandan T S<sup>6</sup>  
<sup>1,2</sup>Assistant Professor, <sup>3,4,5,6</sup>Graduate students, BITM Ballari,

**Abstract:** Aluminium alloy-bottom ash metal matrix composite is produced with different wt % of bottom ash (0%, 4%,4%)with different methods using stir casting method mechanical testing such as wear and bending tests were performed. Characterizations namely x-ray diffraction (XRD) and scanning electron microscope (SEM) analysis were carried the percentage of reinforcement present was confirmed using XRD technique distribution of reinforcement in the composite is viewed through SEM the wear rate of AMMC composite prepared by third method (4% reinforcement) has good wear strength. The bending strength is excellent for 1<sup>st</sup> method; increasing % of reinforcement reduces the bending strength of AMMC.

**Keywords:** Aluminium, Bottom ash, Bending strength, Wear rate, XRD analysis.

## I. INTRODUCTION

Now a day's aluminium alloys are used in majority of applications because of their excellent properties such as higher strength to weight ratio, good corrosion resistance, higher thermal conductivity, and low density. Aluminium also have low melting point, lesser thermal stability, comparatively lesser tensile and fatigue strength than the steels. Aluminium is obtained about 8% of the earth surface, it is the third most abundant constituent recognized by human and it has been found as the largely common metal on earth.

The color of aluminium looks silvery to dull gray. Bottom ash is used as reinforcement because it is least expensive and easily available in large quantity. Powder metallurgy, spray coating, electroplating and stir casting are different methods available to manufacture aluminium metal matrix composites.

Among these method stir casting is more economical and also suitable for the mass production and another reason is in normal casting process the reinforcement is not distributed uniformly in molten metal, to overcome this drawback stir casting process method is used to fabricate cast product.

This work is done to determine the mechanical behaviour such as bending, wear of the aluminium-bottom ash composite with different weight percentages of bottom ash (0%, 4%, 4%) and also to check uniform distribution of bottom ash in the aluminium metal matrix, SEM and XRD tests are also conducted to know the microstructure of aluminium metal matrix composite.

## II. METHODOLOGY

Stir Casting is a liquid state method of composite materials fabrication, in which a dispersed Phase (ceramic particles, short fibres) is mixed with a molten matrix metal by means of Mechanical stirring. The liquid composite material is then cast by conventional casting methods and may also be processed by conventional Metal forming technologies. Stir casting setup consist of crucible placed in the electric furnace.

There is a base stand which holds the motor to which stirrer is connected. the stirrer blades are made of steel, initially crucible is cleaned to remove foreign particles, and electric furnace is switched ON , then the required quantity of aluminium slabs are weighed in the weighing machine and taken in to crucible and is placed into the furnace. After certain time period, the temperature of the furnace reaches to 830<sup>0</sup>c and the metal inside the crucible slowly comes to molten condition. Due to contamination of dust particles, slag or sludge is formed on the surface of molten metal.

And this slag is removed frequently. The aluminium molten metal was degasified to eliminate blow holes in the cast product, and it is done by adding degasifying tablets which allows the gases to escape from the molten metal then the mechanical stirrer is inserted into the molten metal and stirring is carried out until there is a development of swirl in the molten metal, then bottom ash is added and stirring is continued for 5 minutes. So that bottom ash distribute uniformly through the melt. Later stirrer is removed from the molten metal. And the mixture is poured into the metal die or permanent die and is allowed for solidifying



Fig 1 stir casting machine



Fig 2 mechanical stirring



Fig 3 pouring molten metal in to die



fig 4 cast product

### III. STIR CASTING IS DONE IN DIFFERENT METHODS

#### A. Method 1 (0% reinforcement)

Initially crucible is cleaned to remove dust and foreign particles and placed in the furnace. Electric furnace is switched ON and aluminium billets weighing 1.5 kg is added in to the crucible and heated up to 830<sup>0</sup>c to melt the aluminium billets which took 150mins, and the slag formed at the surface of molten metal due to contamination of dust particles is removed, and there by degassing tablet is added in to the crucible to eliminate blow holes and dissolved gasses, and the molten metal is stirred for 5 mins and the molten metal is poured in to the pre heated die and allowed for solidification in the presence of air to get the cast product.

#### B. Method 2 (4% Reinforcement)

Initially crucible is cleaned to remove dust and foreign particles and placed in the furnace. Electric furnace is switched ON and aluminium billets weighing 2 kg is added in to the crucible and heated up to 830<sup>0</sup>c to melt the aluminium billets which took 150mins, and the slag formed at the surface of molten metal due to contamination of dust particles is removed, and bottom ash weighing 4% of aluminium by weight is added to molten metal and thereby degassing tablet is added in to the crucible to eliminate blow holes and dissolved gasses, and the molten metal is stirred for 5 mins and the molten metal is poured in to the pre heated die and allowed for solidification in the presence of air to get the cast product.

#### C. Method 3 (4% Reinforcement)

Initially crucible is cleaned to remove dust and foreign particles and placed in the furnace. Electric furnace is switched ON and bottom ash weighing 4% of aluminium by weight is added and aluminium billets weighing 2 kg is added in to the crucible and heated up to 830<sup>0</sup>c to melt the mixture which took 150mins, and the slag formed at the surface of molten metal due to contamination of dust eliminate blow holes and dissolved gasses, and the molten metal is stirred for 5 mins and the molten metal is poured in to the pre heated die and allowed for solidification in the presence of air to get the cast product.

#### D. Method 4:- (4% Reinforcement)

Electric furnace is switched ON and aluminium powder weighing 2kg is mixed with 100 grams of bottom ash (i.e., 4% of aluminium by weight) and this mixture is placed in the furnace and heated up to 830<sup>0</sup>c to melt the mixture. Due to temperature sharing between the aluminium and bottom ash, the temperature to melt the mixture is high and is not achieved with the furnace. So the cast product obtained is semisolid or crystalline solid, the required product is not obtained.

#### IV. TEST CONDUCTED

##### A. Wear Test

A pin on disc test apparatus shown in fig 3.1 was used to determine the wear behavior of Al2024 metal matrix composite reinforced with bottom ash. Specimens of diameter 6mm and length 30mm were prepared according to ASTM standard G99.

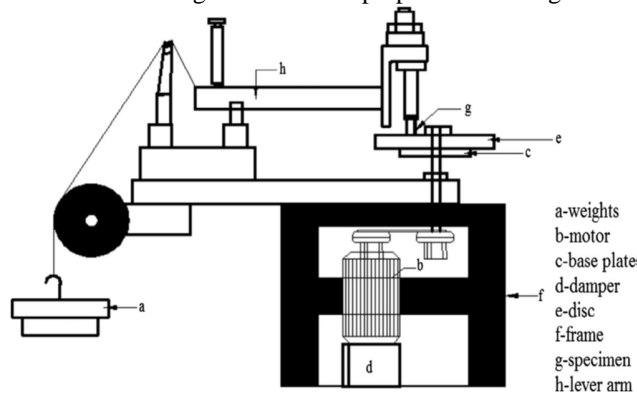

The diameter of the disc is 160 mm and thickness is 8mm, experiment is conducted at track diameter of 90 mm. Initially the specimen is held firmly in the work piece holder and is perpendicular to disc surface. Required load (10N, 20N, 30N) is applied up on the specimen to achieve desired stresses. And disc is made to rotate at a constant speed of 600rpm for a time period of 10mins for each load. Wear rate and frictional forces are recorded continuously through pc based data logging system. Tribo acquire is a proprietary integrated control and data acquisition software used, it is user friendly and has capability to log sample information as entered by the operator for future reference and comparison.

##### B. Bending Test

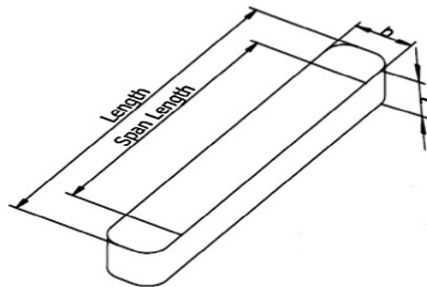

Here

$b=20\text{mm}$ ;

$t=6\text{mm}$ .

Three point bending test was performed to determine the bending strength of aluminium metal matrix composite reinforced with bottom ash and also to evaluate maximum bending load. Specimen of thickness 6mm and width 20 mm are prepared according to ASTM standard E290. This test conducted in universal testing machine

The flexural strength formula is given as:

$$\text{Flexural strength} = M * Y/I$$

M is bending moment; y is distance from the natural axis and I is the moment of inertia. The maximum flexural surface stress occurs in the mid-point of the specimen.

Therefore:

$$M=P*L/4$$

$$Y=t/2$$

$$I=b*t^3/12$$

Where P is the load applied by the testing machine; T is thickness of the specimen; B is breath of the specimen, and L is the span length.

## V. RESULTS AND DISCUSSION

### A. Wear Test

In the graphs trace 0, trace 1, trace 2, represents load 10N,20N,30N respectively.

#### 1) Method 1

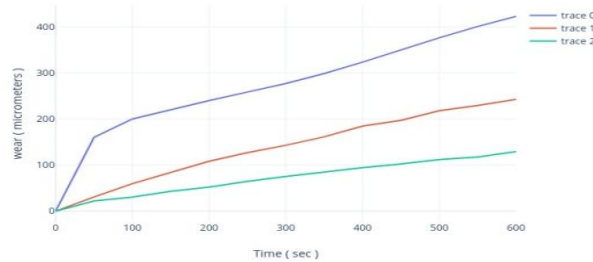

Wear rate under different loads is shown in figure. Under load 10 N the wear rate of specimen is  $422.8\mu\text{m}$ , as load increases to 20N the wear rate is decreased to  $242.8\mu\text{m}$  and further it is decreased to  $130\mu\text{m}$  under 30 N load hence in this method the wear rate of the specimen is decreasing as load increases i.e., the loss of material is decreasing as load increases.

#### 2) Method 2

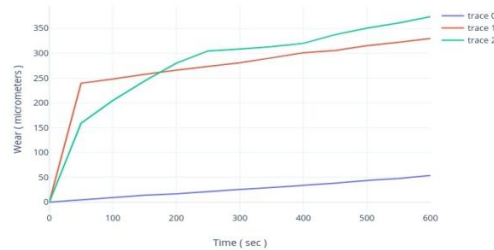

The variation of wear rate and different loads is shown in figure the wear rate of the specimen and 10N load is  $53.8\mu\text{m}$ , as load increases to 20N the wear rate increases to  $330\mu\text{m}$  and further it is increased to  $373\mu\text{m}$  under 30N load hence the wear rate of specimen prepared by using this method increases as load increases i.e., the loss of material increases the load increases.

#### 3) Method 3

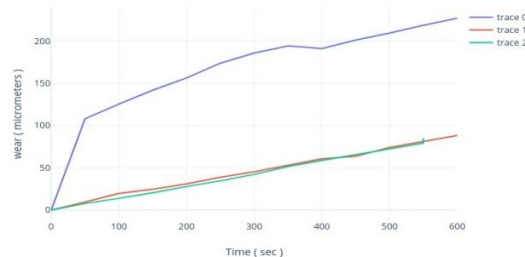

The wear rate of specimen under different load is shown in figure the wear rate under load 10N is  $228\mu\text{m}$  and it is decreases to  $88\mu\text{m}$  and  $85\mu\text{m}$  under load 20N and 30N respectively hence the wear rate gets decreases as load increases that is loss of material is getting less as load increases.

**B. Bending Test**

Method 1

Method 2

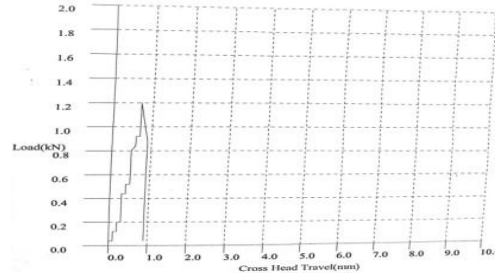
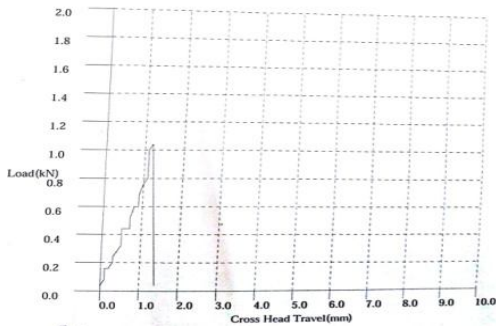

Method 3

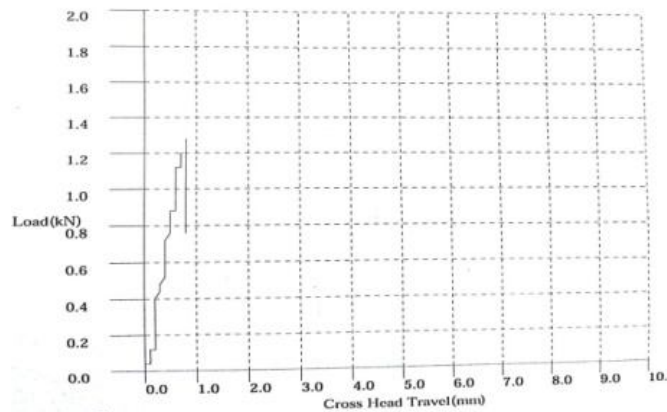

From the graph the bending strength of aluminium metal matrix composite is decreasing from method 1 to method 3 i.e., by the addition of bottom ash bending strength of the composite getting decrease. The specimen prepared in method 1 has the maximum bending strength of 10.67 N/mm<sup>2</sup>. By addition of 4% of bottom ash In method 2, the bending strength is decreased to 10N/mm<sup>2</sup> and it is further decreased to 8.67N/mm<sup>2</sup> in method 3. The load required to bend the specimen is Maximum for method 1 compared to other methods, hence the composites prepared by method 2 and method 3 can be used in applications having less bending strength.

Bending load		
PURE ALUMINUM (METHOD 1)	AL-4% OF BOTTOM ASH (METHOD 2)	AL-4% OF BOTTOM ASH (METHOD 3)
1.28 KN	1.20 KN	1.04KN

C. SEM Analysis

1) 1<sup>st</sup> Method

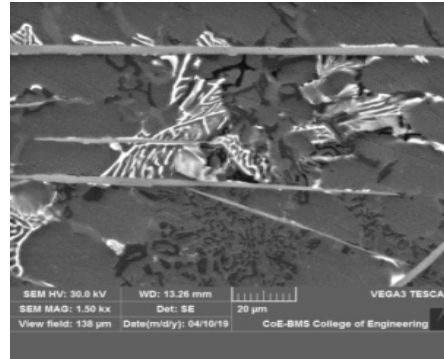
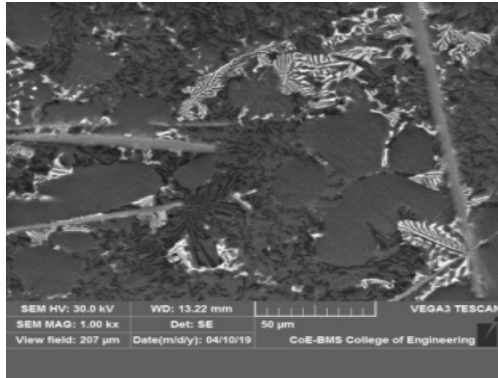

2) 2<sup>nd</sup> Method

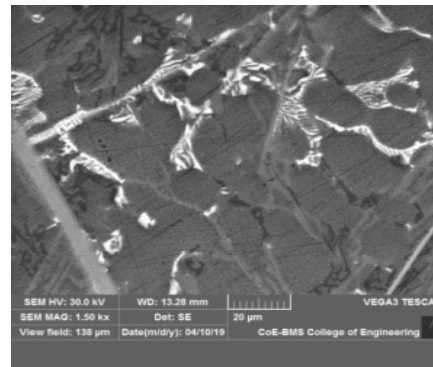
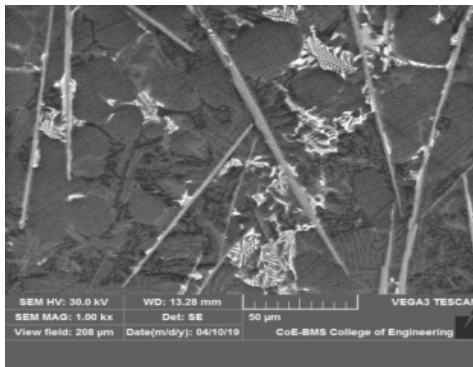

3) 3<sup>rd</sup> Method

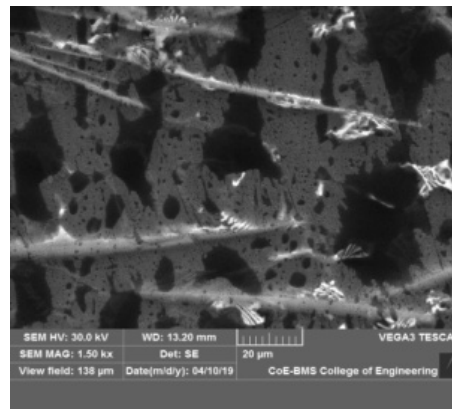
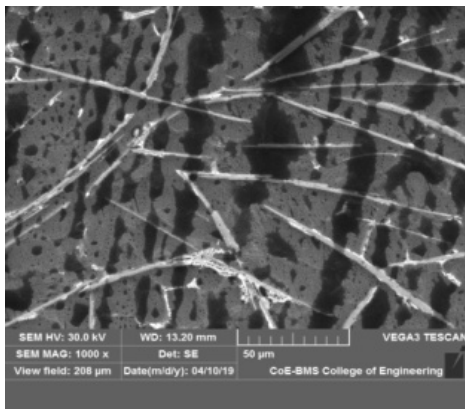

The size and shape of bottom ash particles has been observed under SEM and the results are shown in figures the size of the reinforcement particles in the range of 20µ to 50µ.

In the first method as show in fig 1&2 aluminium and its constituents dispersed uniformly and there is less porosity. In second method as shown in figure 3 & 4 the reinforcement particle of size ranging 20µ to 50µ is uniformly distributed in aluminium metal matrix and porosity is less (the dark spots not clearly visible). In third method as shown in fig 5&6 the reinforcement is not uniformly mixed in aluminium metal matrix, and the porosity obtained is more.

#### D. X-Ray Diffraction

The specimens have been examined for their X-ray diffraction (XRD) pattern using x-ray diffractometer in the  $2\theta$  range  $20^{\circ}$  to  $90^{\circ}$  using Cu, as target material, the step size and dwell time were suitably adjusted which was used for identification of various phases.

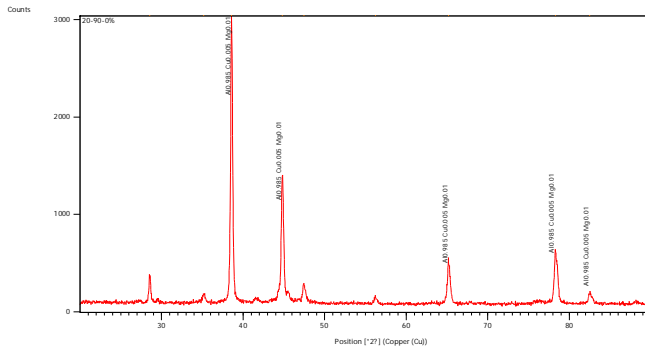

1) Fig 1. (Al<sub>0.985</sub> Cu<sub>0.005</sub> Mg<sub>0.01</sub>)

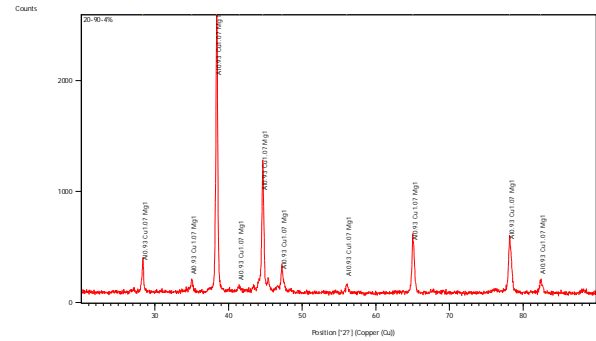

2) Fig 2. (Al<sub>0.985</sub> Cu<sub>0.005</sub> Mg<sub>0.01</sub>)

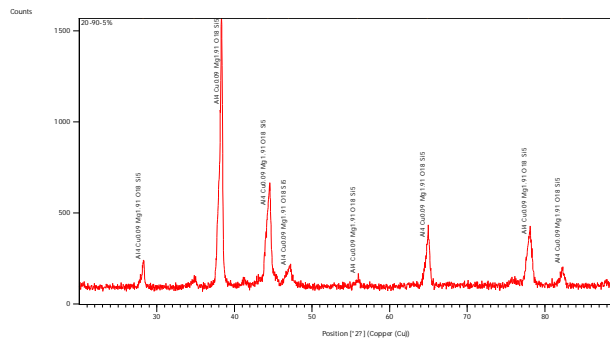

3) Fig 3. (Al<sub>4</sub> Cu<sub>0.09</sub> Mg<sub>1.91</sub> O<sub>18</sub> Si<sub>5</sub>)

### VI. CONCLUSION

From this study presence of bottom ash reinforcement had confirmed using XRD techniques for various wt% of Al2024-bottom ash composite. The size and shape of bottom ash particles has been observed under SEM and the size of the reinforcement particles in the range of  $20\mu$  to  $50\mu$ . Mechanical testing such as wear strength, bending strength were evaluated. Maximum bending load is 1.28kN was observed in cast product prepared by method 1, wear strength is good in specimen prepare by method 3.

### REFERENCES

- [1] Siva Sankara Raju "Tribological behaviour of al-1100-coconut shell ash (CSA) composite at elevated temperature" JTRI5355 2018 <https://doi.org/10.1016/j.triboint.2018.08.011>
- [2] A. Baradeswaran, A. Elaya Perumal "Tribology International (2018), doi: 10.1016/j.triboint.2018.08.011.2) Study on mechanical and wear properties of Al 7075/Al<sub>2</sub>O<sub>3</sub>/graphite hybrid composites" [doi.org/10.1016/j.compositesb.2013.08.013](https://doi.org/10.1016/j.compositesb.2013.08.013), year 2013.
- [3] S.E.Shin/D.H.Bae "Fatigue behavior of Al2024 alloy-matrix nanocomposites reinforced with multi-walled carbon nanotubes" <https://doi.org/10.1016/j.compositesb.2017.09.034>.
- [4] Dr.Sc.Thoislav Filetin "BENDING STIFFNESS OF ALUMINIUM FOAMS" <http://repositorij.fsb.hr/id/eprint/4392>
- [5] A.AlahelistenF.BergmanM.OlssonS.Hogmark "On the wear of aluminium and magnesium metal matrix composites" Department of Technology, Materials Science Division, Uppsala University, Box 534 S-751 21 UppsalaSwede [https://doi.org/10.1016/0043-1648\(93\)90338-M](https://doi.org/10.1016/0043-1648(93)90338-M) 20 February 2003.
- [6] D.k.shin, H.C.kim, J.J.lee "Numerical analysis of the damage behaviour of an aluminium/CFRP hybrid beam under three point bending" Mechanical Engineering, Korea Advanced Institute of Science and Technology, Daehak-ro 291, Daejeon 305-701, Republic of korea <https://doi.org/10.1016/j.compositesb.2013.08.030> 20 August 2013.
- [7] B. T. Ramesh, R. P. Swamy, Koppad Vinayak "Mechanical characterization of Al-2024 reinforced with fly ash and E-glass by stir casting method" AIP Conference Proceedings 1943, 020101 (2018): <https://doi.org/10.1063/1.5029677>





10.22214/IJRASET



45.98



IMPACT FACTOR:  
7.129



IMPACT FACTOR:  
7.429



# INTERNATIONAL JOURNAL FOR RESEARCH

IN APPLIED SCIENCE & ENGINEERING TECHNOLOGY

Call : 08813907089  (24\*7 Support on Whatsapp)