



iJRASET

International Journal For Research in
Applied Science and Engineering Technology



INTERNATIONAL JOURNAL FOR RESEARCH

IN APPLIED SCIENCE & ENGINEERING TECHNOLOGY

Volume: 7 Issue: V Month of publication: May 2019

DOI: <https://doi.org/10.22214/ijraset.2019.5694>

www.ijraset.com

Call:  08813907089

E-mail ID: ijraset@gmail.com

Performance of Phase Transmit Sequence in LS/LMMSE based channel estimated MIMO-OFDM System

Poonam T. Agarkar¹, Akshay S. Chaware², Dr. Sanjay L. Badjate³

¹Assistant Professor, Rajiv Gandhi College of Engineering & Research, Nagpur

²PG Scholar, ³Principal, S. B. Jain Institute of Technology, Management & Research, Nagpur

Abstract: Orthogonal Frequency Division Multiplexing (OFDM) is one of the most promising multi-carrier system which forms basis for all 4G wireless communication systems due to its large capacity to allow the number of subcarriers, high data rate and ubiquitous coverage with high mobility. OFDM is significantly affected by Peak to Average Power Ratio (PAPR). Unfortunately, the high PAPR inherent to OFDM signal envelopes will occasionally drive high power amplifiers (HPAs) to operate in the nonlinear region of their characteristic curve. The nonlinearity of the HPA exhibits amplitude and phase distortions, which cause loss of orthogonality among the subcarriers, and hence, inter-carrier interference (ICI) is introduced in the transmitted signal. The high PAPR also leads to in-band distortion and out-of-band radiation. To increase the performance of OFDM signals, the partial transmit sequence (PTS) shows a significant reduction and improvement in PAPR. As one of attractive techniques, PTS scheme provides an effective solution for PAPR reduction of OFDM signals. Theoretical analysis and simulation in literature using single input single output (SISO) with PTS results showed that, PTS can not only dramatically reduce computational complexity but also have an advantage of no loss in PAPR reduction performance. This proposed work emphasis mainly on the PAPR reduction in Multi input multi output (MIMO) -OFDM system using PTS technique with Least square (LS) and Least minimum mean Wireless communications is one of the most active areas of technology development and a rapidly growing branch of the wider field of communications Systems. It is called wireless because it involves the use of wireless channels rather than wire line channels. This rapid growth has been coupled closely with the technological advances of our time. It is worth noting that telecommunications in the 21st century is increasingly relying on the wireless link. This is because wireless communication has made possible a variety of services ranging from voice to data and now to multimedia. As a result, similarly to what happened to wire line capacity in the late 1990s, the demand for new wireless capacity is now growing at a very rapid rate. Nevertheless, the wireless communication system is consistently faced with diverse challenges. These include the sparsely available radio frequency spectrum and a complex squared error (LMMSE) channel estimations techniques. The results obtained showed that PTS gives low Bit error rate (BER) as compared to system without PTS with both channel estimation techniques for a range of values for signal to noise ratio (SNR).

Keywords: Orthogonal frequency division multiplexing, Peak to Average Power Ratio, Partial Transmit Sequence, Least Square, Linear-minimum-mean-square-error, Bit Error Rate.

I. INTRODUCTION

space-time varying wireless environment. Besides these, the system is also confronted with challenges of an increasing demand for higher data rates, better quality of service, and higher network capacity [1]. Consequently, there is a migration from Single-Input Single-Output antenna technology to a more promising Multiple-Input Multiple-Output antenna technology for deployment in the wireless communications Systems. The idea of using multiple antennas at both transmit and receive ends has emerged as one of the major technical breakthroughs in modern wireless communications system.

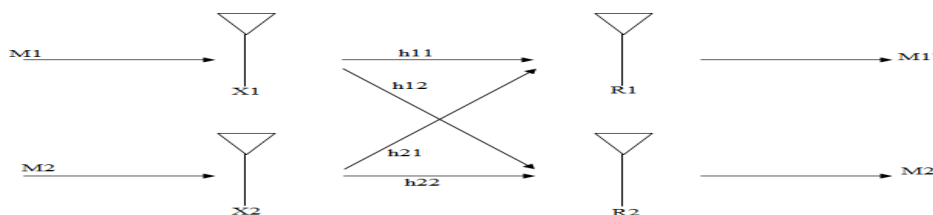

Figure 1- Transmit and Receive (2x2) MIMO System with channel coefficients

$$X = [X_0, X_1, X_2, X_3, \dots, X_{V-1}]$$

Where, V is represented as the dimension of total number of data, and X is mentioned as the input data.

Initially, the input frequency domain OFDM sequences are modulated into Theoretical studies and initial prototyping of MIMO systems have shown a high order of magnitude in spectral efficiency improvements for point-to-point communication [2,3]. As a result, MIMO is considered a key technology for improving the throughput of future wireless broadband data systems, which as at present are mired at data rates far below their wired counterparts. The schematic diagram of 2x2 MIMO system is shown in figure 1. MIMO is a wireless technology that uses multiple transmitters and receivers to transfer more data at the same time. The MIMO system combined the performance gains that are achievable in both the transmit antenna diversity and the receive antenna diversity systems with the use of multiple antennas at both end of the communication link. The main idea behind MIMO is that signals sampled in the spatial domain at both ends are combined in such a way that they either create effective multiple parallel spatial data channels (therefore increasing the data rate), and/or add diversity to enhance the bit-error rate performance of the Systems. The idea of spatial diversity is that in the presence of random fading occasioned by multipath propagation, SNR is significantly improved by combining the output of de-correlated antenna elements. The early 1990s witnessed new proposals for using antenna arrays to increase the capacity of wireless links thereby creating several opportunities beyond just diversity [1].

Orthogonal frequency-division multiplexing that is OFDM is a method of encoding digital data on multiple carrier frequencies. A special case of multicarrier transmission known as OFDM is one of the most widely used technologies in current wireless communications systems. OFDM is also seen as a potential candidate for the future generation of the mobile wireless Systems, especially the fourth generation (4G) Systems [4]. OFDM is a multicarrier modulation technique that can overcome many problems that arise with high bit rate communications. The data bearing symbol stream is split into several lower rate streams and these streams are transmitted on different carriers. Since this splitting increase the symbol duration by the number of orthogonally overlapping carriers, multipath resonances affect only a minor portion of the adjacent symbols. Remaining inter-symbol interference (ISI) is removed by extending the OFDM symbol with a cyclic prefix (CP). Using this method, OFDM reduces the dispersion effect of multipath channels encountered with high data rates and reduces the need for complex equalizers.

Though, one of the major concerns in OFDM is PAPR of the transmitted time domain signals, which indicates in-band radiation and out-of-band distortion in the non-linear region of power amplifier. Due to this non-linear process, the OFDM system consumes high power to execute the operation [5,6].

As a result, the high PAPR brings on OFDM signal distortion in the nonlinear region of high power amplifier, and this signal distortion induces degradation of high BER and adjacent channel interference. To avoid the occurrence of large PAPR of OFDM signals, various schemes for PAPR reduction have been presented [7,8], such as coding [9], companding [10,11], clipping and filtering [12], constellation extension [13], tone reservation and injection [14,15], selected mapping [16,17] and partial transmit sequence [18]. Among all existing schemes, partial transmit sequence [18] is very promising because of its good PAPR reduction performance without any signal distortion. Priyanka Singh Jadon and Prof. Pankaj Sharma [19] emphasised mainly on the PAPR reduction of OFDM system using partial transmits sequence and precoding techniques. K. Kanthi Kumar, Adimulam Yesu Babu, Battula Tirumala Krishna [20] focused on improving the SLM-PTS method with the improvement in new regressive group phase weighting approach. Poudel B and Mishra B [21] proposed two PAPR reduction technique; SLM and Optimum-PTS for reducing the PAPR and compared these two techniques on the basis of reduction in PAPR level, BER and the number of redundant bits required. Abdelhakim Khelifi and Ridha Bouallegue [22] evaluated the performance of LS and LMMSE estimation techniques for LTE Downlink systems under the effect of the channel length.

II. PROPOSED METHODOLOGY

Partial Transmit Sequence is one of the techniques used to reduce PAPR in OFDM system. The OFDM system partition the individual radio signal into equally spaced sub-signals to deliver high data broadcast with less signal distortion. The initial OFDM sequences are in frequency domain, which is represented in the equation,

time domain sequences, by employing IFFT. Hence, the OFDM model encodes only the digital data on multi-carrier frequency. Respective sub-carrier sequences are selected orthogonally to achieve multiple transmissions. The time domain signals are mathematically represented in the equation,

$$x_v = \frac{1}{\sqrt{V}} \sum_{k=0}^{v-1} X_k P_k^{cv}$$

where, x_v is signified as the signal proceed after IFFT procedure, c_v is illustrated as the orthogonal value of sub-carrier and P is demonstrated as phase factors.

To strengthen the performance of PAPR reduction, the shifting scheme is included in between the data signals. Then, the signal carrier system is associated with the summation of OFDM symbol sub-carriers, which leads to high peak power. This high peak

power is represented as the proportion between average power and maximum power of sub-carriers. It is expressed in the equation,

$$PAPR = 10 \log_{10} \frac{\max \{|x_v|^2\}}{E \{|A_v|^2\}}$$

where, $E \{|A_v|^2\}$ is represented as the average power of x_v and it is composed in the frequency domain, because IFFT is a scaled unitary transformation.

To perform the operation, the input block X is categorized into several individual sub-blocks V that are represented in the vectors as X_v , $v = 1, 2, \dots, V$. The respective equation is specified in the equation,

$$X = \sum_{v=1}^V X_v$$

To retrieve the original OFDM signal, all the sub-carriers position of the additional sub-block is considered as zero. Implementing of disjoint sub-blocks and zero insert sequences are characterized in Table 1.

Table 1-PTS Insertion

X : IFFT input						
Sub-blocks				Insert Sequences		
1	2	...	V - 1	1	...	V

A. Group Phase Weighting (GPW)

In this section, simulation has been conducted to estimate the performance of PTS with GPW. Each sub-block sequences are individually weighted by employing phase weighting factors (PWF). All the weighted sub-block candidate sequences are combined to get an OFDM sequence, which is mathematically expressed in the equation.

$$x' = IFFT \left\{ \sum_{v=1}^V b_v X_v \right\} = \sum_{v=1}^V b_v IFFT \{X_v\} = \sum_{v=1}^V b_v x_v$$

Where, b_v is mentioned as PWF and x_v is represented as a sub-block sequence.

By applying numerous PWF, a number of OFDM is obtained. In that, the one with lowest PAPR is determined for transmitting.

Assuming, the quantity of sub-blocks are $V = 4, (x_1, x_2, x_3, x_4)$ and the set of PWF P is symbolized as $\{1, -1\}$. Respective four sub-blocks are classified into two groups $R = 2$ and the first two sub-blocks x_1 and x_2 are in the first group and the remaining x_3 and x_4 are denoted in the second group. Phase weighting sequence (PWS) of each group is represented in the equation,

First group = $[1, 1]^T, [1, -1]^T$

Second group = $[1, 1]^T, [1, -1]^T, [-1, 1]^T$ and $[-1, -1]^T$

The sub-blocks are multiplied with the combination of phase factors $\{1, -1\}$ as shown above. Hence, the sub-candidate sequences from the first group and the second group is achieved by applying the phase weight sequences respectively, it is represented in the equations,

First group sub-candidate sequence,

$$G_{11} = x_1 + x_2, \quad G_{12} = x_1 - x_2$$

Second group sub-candidate sequence,

$$G_{21} = x_3 + x_4, \quad G_{22} = x_3 - x_4,$$

$$G_{23} = -x_3 + x_4, \quad G_{24} = -x_3 - x_4$$

Totally, eight output OFDM candidate sequences are obtained, by combining the both sub-candidate sequence of both first order and second order groups. The respective OFDM sequences y are mentioned in the equation,

$$y_1 = G_{11} + G_{12} = x_1 + x_2 + x_3 + x_4 = [1, 1, 1, 1]$$

$$y_2 = G_{11} + G_{22} = x_1 + x_2 + x_3 - x_4 = [1, 1, 1, -1]$$

$$y_3 = G_{11} + G_{23} = x_1 + x_2 - x_3 + x_4 = [1, 1, -1, 1]$$

$$y_4 = G_{11} + G_{24} = x_1 + x_2 - x_3 - x_4 = [1, 1, -1, -1]$$

$$y_5 = G_{12} + G_{21} = x_1 - x_2 + x_3 + x_4 = [1, -1, 1, 1]$$

$$y_6 = G_{12} + G_{22} = x_1 - x_2 + x_3 - x_4 = [1, -1, 1, -1]$$

$$y_7 = G_{12} + G_{23} = x_1 - x_2 - x_3 + x_4 = [1, -1, -1, 1]$$

$$y_8 = G_{12} + G_{24} = x_1 - x_2 - x_3 - x_4 = [1, -1, -1, -1]$$

In GPW, each element in PWS needs LN complex multiplications, where L is the over-sampling factor. Thus, the PWS which contains fewer elements have lower computational complexity for generating candidate sequence.

The fundamental idea of this technique is sub-dividing the original OFDM symbol data into sub-data which is transmitted through the sub-blocks which are then multiplied by the weighing value which were differed by the phase rotation factor until choosing the optimum value which has low PAPR. The schematic diagram of PTS scheme is shown in Figure 2.

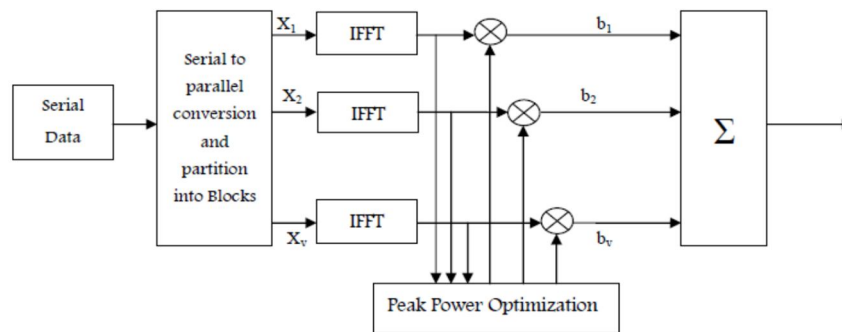

Figure 2- Block Diagram of PTS scheme

B. MIMO-OFDM System with PTS Scheme

1) At Transmitter:

- a) Initialize the parameters
 - i. Number of transmitting and receiving antennas = 2×2
 - ii. Number of Data Symbols = 32 (Binary)
 - iii. Guard Band = 16 symbols
 - iv. Modulation scheme = Binary
 - v. Length of each group for grouping = 16
 - vi. Data positions = All even places from 2 to 64
 - vii. Pilot positions = All odd places from 1 to 63
- b) Generate complex random pilot signals p_1 and p_2 for 2×2 MIMO.
- c) Generate complex random channel coefficients = $h_{11}, h_{12}, h_{21}, h_{22}$.
- d) The signal to noise ratio values are considered from 0 to 40dB at an interval of 5dB.
- e) Generate random data for both transmitting antennas.
- f) Modulate the data vectors using QAM scheme.
- g) Insert pilots.
- h) Apply IFFT to both signals for without PTS scheme.
- i) Apply PTS scheme to signals.
- j) Add cyclic prefix to results from step 8 and step 9.
- k) Add the effect of channel coefficients to results obtained after step 10.
- l) Combine vectors from both transmitters.
- m) Add additive which is Gaussian noise to the signals.

2) At Receiver:

- a) Receive the signals.
- b) Remove pilots from the signals.
- c) Apply FFT for without PTS scheme.
- d) For PTS scheme,
 - i. Separate groups
 - ii. As per index, find the data groups with minimum PAPR, i.e transmitted vectors.
 - iii. Find FFT for all eight vectors.
- e) Get the transmitted vectors with pilots.
- f) Extract data by removing pilots.

The LS Estimate

Here, we have the following vectors after step 19.

X – Transmitted Pilots

Y – Received Pilots

Z – Received Data vectors without PTS scheme

W – Received Pilot vectors without PTS scheme

For LS Estimate,

$$\begin{aligned} v_1 &= X' \cdot X; \\ v_2 &= \text{inv}(v_1); \\ v_3 &= Y' \cdot X; \\ H_{LS} &= v_2 \cdot v_3; \\ u_3 &= W' \cdot X; \\ H_{LSW} &= v_2 \cdot u_3; \end{aligned}$$

Data vectors for LS are,

$$\begin{aligned} X_{RLS} &= (\text{inv}(H_{LS}) \cdot Y'_v); \\ X_{RLSW} &= (\text{inv}(H_{LSW}) \cdot Z'); \end{aligned}$$

g) Demodulate the vectors.

h) Estimate the bit error rate (BER).

For LMMSE Estimate,

$$\begin{aligned} \text{Sigma} &= 10^{\left(\frac{\text{SNR}}{10}\right)}; \\ t_1 &= \frac{(X' \cdot X)}{(N_r \cdot \text{sigma})}; \\ t_2 &= \frac{\text{eye}(N_t)}{(N_r \cdot \text{sigmah})}; \quad \text{where, sigmah} = 0.25 \\ t_3 &= \text{inv}(t_1 + t_2); \\ t_4 &= \frac{(X' \cdot Y)}{(N_r \cdot \text{sigma})}; \\ H_{LMMSE} &= (t_3 \cdot t_4); \\ t_5 &= \frac{(X' \cdot W)}{(N_r \cdot \text{sigma})}; \\ H_{LMMSEW} &= (t_3 \cdot t_5); \end{aligned}$$

Data Vectors,

$$\begin{aligned} X_r &= (Y_r \cdot \text{inv}(H_{LMMSE}))'; \\ X_{rW} &= (Z \cdot \text{inv}(H_{LMMSEW}))'; \end{aligned}$$

i) Demodulate the data vectors.

j) Estimate bit error rate (BER).

k) Repeat step 6 to step 23 for 100 times.

l) Calculate mean of BER values obtained from 100 iterations.

m) Continue step 5 to 25 for all values of SNR from 0 to 40dB.

n) Plot results.

C. PTS Scheme

1) Split the vectors into 4 equal groups.

$$x_1 = \text{Data}(16)$$

$$x_2 = \text{Data}(16)$$

$$x_3 = \text{Data}(16)$$

$$x_4 = \text{Data}(16)$$

2) Get the IFFT response.

3) Padd all the vectors

$$x_1 = \text{Data}(16) \quad \text{Zero}(16) \quad \text{Zero}(16) \quad \text{Zero}(16)$$

$$x_2 = \text{Zero}(16) \quad \text{Data}(16) \quad \text{Zero}(16) \quad \text{Zero}(16)$$

$$x_3 = \text{Zero}(16) \quad \text{Zero}(16) \quad \text{Data}(16) \quad \text{Zero}(16)$$

$$x_4 = \text{Zero}(16) \quad \text{Zero}(16) \quad \text{Zero}(16) \quad \text{Data}(16)$$

4) Solve the group phase weighting equations.

5) Calculate the PAPR ratio

$$PAPR = 10 \log_{10} \left(\frac{\text{Power Peak Amplitude}}{\text{Power Average}} \right)$$

6) Select the signal with minimum PAPR.

III. RESULTS AND CONCLUSION

According to studies made different researchers, the performance based on BER v/s SNR, the LS estimate is good at higher noise level while LMMSE performs well as the noise is reduced. The performance graphs shown in figure 3 and figure 4 clearly indicates that the BER for LMMSE is low as compared to BER of LS estimate in both the cases, that is with and without PTS scheme. The proposed PTS scheme makes the BER to be zero at 20dB value of SNR as compared to 25dB SNR for without PTS scheme.

The PTS scheme uses simple mathematical calculations such as addition, subtraction with overhead of only PAPR calculations. Therefore, the proposed PTS scheme reduces complexity of the system. The performance of LS and LMMSE estimation can be combined to get best of the two for low BER values.

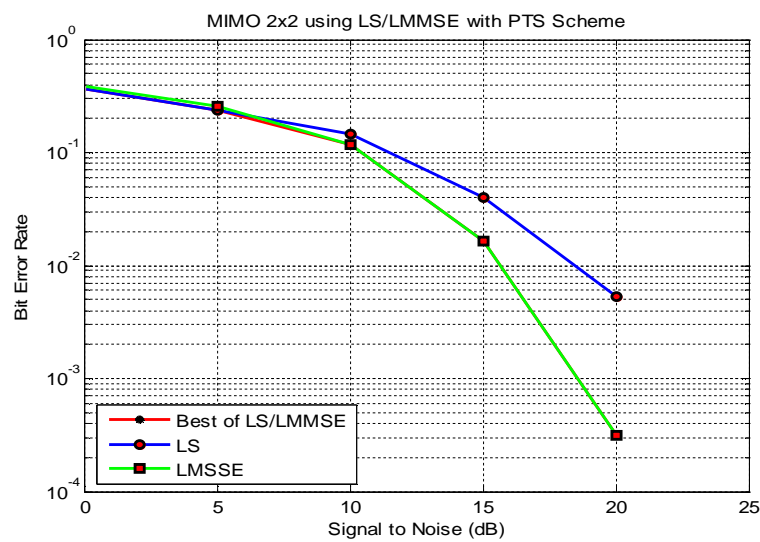

Figure 3-Performance of 2x2 MIMO-OFDM system using LS/LMMSE without PTS scheme

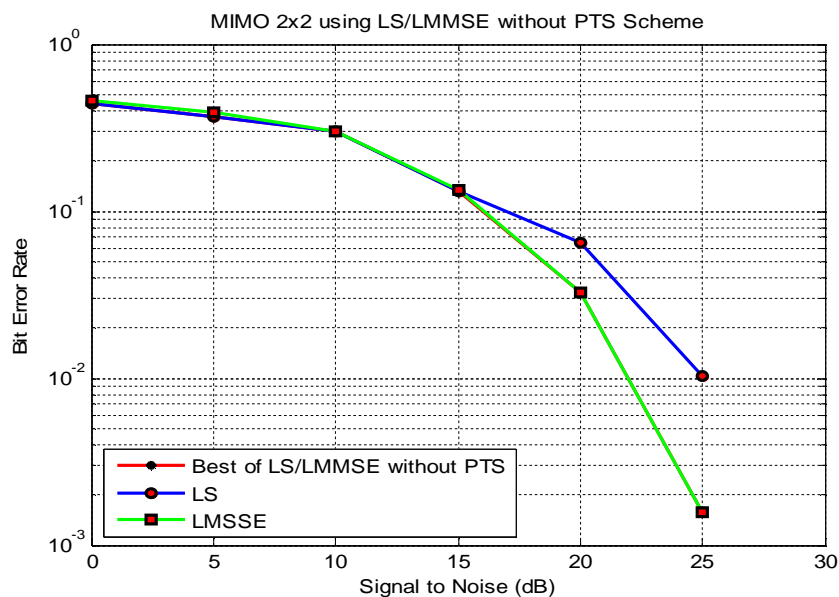

Figure 4 -Performance of 2x2 MIMO-OFDM system using LS/LMMSE with PTS scheme

REFERENCES

- [1] C. Oestges and B. Clerckx, "Wireless Communications from Real-World Propagation to Space-Time Code Design", Elsevier Academic Press, 480 pages, Mar. 2007.
- [2] A. J. Paulraj and T. Kailath, "Increasing capacity in wireless broadcast Systems using distributed transmission/directional reception," U. S. Patent, no. 5,345,599, 1994
- [3] H. Bolcskei, D. Gesbert, and A. J. Paulraj, "On the capacity of OFDM-based spatial multiplexing systems," *IEEE Transaction on Communication*, vol. 50, no. 2, pp. 225- 234, Feb. 2002.
- [4] S. Hara and R. Prasad, "Multicarrier Techniques for 4G Mobile Communications", ArtechHouse, Inc. Norwood, MA, USA, 268 pages, 2003.
- [5] Goel A., Gupta P., Agrawal M, "SER analysis of PTS based techniques for PAPR reduction in OFDM systems", *Digit. Signal Proc.* **23**(1), 302–313 (2013)
- [6] Lim, D.-W., Noh, H.-S., Jeon, H.-B., No, J.-S., Shin, D.-J, "Multistage TR scheme for PAPR reduction in OFDM signals", *IEEE Trans. Broadcast.* **55**(2), 300–304 (2009)
- [7] T. Jiang and Y. Wu, "An overview: peak-to-average power ratio reduction techniques for OFDM signals," *IEEE Trans. Broadcast.*, vol. 54, no. 2, pp. 257–268, Jun. 2008.
- [8] O.-J. Kwon and Y.-H. Ha, "Multi-carrier PAP reduction method using sub-optimal PTS with threshold," *IEEE Trans. Broadcast.*, vol. 49, no. 2, pp. 232–236, Jun. 2003.
- [9] M.-J. Hao and C.-H. Lai, "Precoding for PAPR reduction of OFDM signals with minimum error probability," *IEEE Trans. Broadcast.*, vol. 56, no. 1, pp. 120–128, Mar. 2010.
- [10] J. Hou, J. Ge, D. Zhai, and J. Li, "Peak-to-average power ratio reduction of OFDM signals with nonlinear companding scheme," *IEEE Trans. Broadcast.*, vol. 56, no. 2, pp. 258–262, Jun. 2010.
- [11] S. A. Aburakhia, E. F. Badran, and E. Mohamed, "Linear companding transform for the reduction of peak-to-average power ratio of OFDM signals," *IEEE Trans. Broadcast.*, vol. 55, no. 1, pp. 155–160, Mar. 2009.
- [12] J. Armstrong, "Peak-to-average power reduction for OFDM by repeated clipping and frequency domain filtering," *Electron. Lett.*, vol. 38, no. 5, pp. 246–247, Feb. 2002.
- [13] B. S. Krongold and D. L. Jones, "PAR reduction in OFDM via active constellation extension," *IEEE Trans. Broadcast.*, vol. 49, no. 3, pp. 258–268, Sep. 2003.
- [14] D.-W. Lim, H.-S. Noh, H.-B. Jeon, J.-S. No, and D.-J. Shin, "Multistage TR scheme for PAPR reduction in OFDM signals," *IEEE Trans. Broadcast.*, vol. 55, no. 2, pp. 300–304, Jun. 2009.
- [15] J. Tellado, "Peak to average power reduction for multicarrier modulation," Ph.D. Thesis, Stanford University, 1999.
- [16] E. Hong and D. Har, "Peak-to-average power ratio reduction in OFDM systems using all-pass filters," *IEEE Trans. Broadcast.*, vol. 56, no. 1, pp. 114–119, Mar. 2010.
- [17] L. Yang, K. K. Soo, Y. M. Siu, and S. Q. Li, "A low complexity selected mapping scheme by use of time domain sequence superposition technique for PAPR reduction in OFDM system," *IEEE Trans. Broadcast.*, vol. 54, no. 4, pp. 821–824, Dec. 2008.
- [18] S. H. Muller and J. B. Huber, "OFDM with reduced peak-to-average power ratio by optimum combination of partial transmit sequences," *Electron Lett.*, vol. 33, no. 5, pp. 368–369, Feb. 1997
- [19] Priyanka Singh Jadon, Prof. Pankaj Sharma, "Survey paper on PAPR reduction for MIMO-OFDM systems using PTS scheme", *International Research Journal of Engineering and Technology (IRJET)* e-ISSN: 2395-0056, Volume: 05 Issue: 06, June 2018
- [20] K. Kanthi Kumar, Adimulam Yesu Babu, Battula Tirumala Krishna, "Regressive group phase weighting in PTS combined with SLM approach for PAPR reduction in OFDM systems", Springer Science + Business Media, LLC 2017, 24 November, 2017
- [21] Poudel B, Mishra B, Performance Analysis of PAPR Reduction in 4x4 Spatially Multiplexed MIMO-OFDM System using SLM and Optimum-PTS Techniques, *Journal of Telecommunications System Management*, Volume 5, ISSN: 2167-0919, 2016
- [22] Abdelhakim Khelifi and Ridha Bouallegue, "Performance Analysis of LS and LMMSE Channel Estimation Techniques for LTE Downlink Systems", *International Journal of Wireless & Mobile Networks (IJWMN)* Vol. 3, No. 5, October 2011



10.22214/IJRASET



45.98



IMPACT FACTOR:
7.129



IMPACT FACTOR:
7.429



INTERNATIONAL JOURNAL FOR RESEARCH

IN APPLIED SCIENCE & ENGINEERING TECHNOLOGY

Call : 08813907089  (24*7 Support on Whatsapp)