



IJRASET

International Journal For Research in
Applied Science and Engineering Technology



INTERNATIONAL JOURNAL FOR RESEARCH

IN APPLIED SCIENCE & ENGINEERING TECHNOLOGY

Volume: 7 Issue: VI Month of publication: June 2019

DOI: <http://doi.org/10.22214/ijraset.2019.6385>

www.ijraset.com

Call:  08813907089

E-mail ID: ijraset@gmail.com

Motion Control Analysis of Quadcopter with PID Controller

Ch.V.N.Raja¹, Vegi Kovida², K. Rama Sudha³

¹Assistant Professor, Dept. of EEE, Anil Neerukonda Institute of Technology and Sciences, Visakhapatnam, India

²M.Tech Student (Control Systems Engineering) EEE, Anil Neerukonda Institute of Technology and Sciences, Visakhapatnam, India

³ Professor, EEE, AU college of Engineering, Andhra University, Visakhapatnam, India

Abstract: Unmanned Aerial Vehicle (UAV) widely used in Aerial surveillance, Remote sensing and Transport system. UAV with four propeller, known as Quadcopter. Quadcopter requires high flexibility and narrow area mobility. To analyze the behaviour of quadcopter, the dynamic model of the quad-rotor is required. Quadcopter is inherently unstable as it cannot recover to straight and level flight when there is momentary change in the control inputs unlike aircrafts. In this paper, to reduce the effect of momentary control inputs on stability of the Quad-rotor proposed PD and PID controllers by the MATLAB simulation.

Keywords: Quadcopter, Quadrotor, Unmanned Aerial Vehicle (UAV), Vertical Take-Off and Landing (VTOL), MATLAB 2013a

I. INTRODUCTION

An Unmanned Aerial Vehicle (UAV) is a vehicle which is able to fly without a human on board; nevertheless, it can be controlled remotely by human or can fly autonomously [1]. There are two types of UAV: rotary wing and fixed wing. Quadcopter is a rotary wing type UAV. It is named as quadcopter as it has four rotors and propellers placed on the main body [2]. Compared with the other flying vehicles, quadcopter has the advantage of vertical take-off and landing (VTOL) which allows the advantage of moving instantly in any direction at low speed but VTOL require more power in order to levitate and hovering. The attitude of the quadcopter can be controlled by varying the speeds of the four butterfly distribution rotors ([3], [4]). A quadcopter is a rotor craft UAV which is lifted by four rotors. Unlike traditional helicopters, quadcopters do not need variable pitch blades to adjust their direction. Instead, by changing the speed of the rotors, which are placed with the equal distance to the centre of quadcopter, they are able to perform agile and complex and maneuvers [5]. Four rotors provide 6 Degrees of Freedom (DoF) for a typical quadcopter, which brings high maneuverability and lift capacity however increases instability. This makes quadcopter unstable and makes it unable to return to straight and level flight when there is momentary change in the control inputs unlike aircrafts [6]. To stabilise the quadcopter during the flight a low level controller is designed. The research field is still facing some challenges in the control field because the quadrotor is a highly nonlinear, multivariable system and since it has six Degrees of Freedom (DOF) but only four actuators, it is an under actuated system. Under actuated systems are those having a less number of control inputs compared to the system's degrees of freedom. They are very difficult to control due to the nonlinear coupling between the actuators and the degrees of freedom ([7], [8]). In this paper: section II describes the mathematical modelling of quadcopter, the design of PD controller is discussed in section III, the design of PID controller is discussed in section IV and in section V describes the responses of the quadcopter with PD and PID controllers.

II. MATHEMATICAL MODELLING

A quadrotor has four rotors with fixed angles which represent four input forces and has six output states ($x, y, z, \phi, \theta, \Psi$). To obtain motion in the quadcopter in any direction, the quadcopter must rotate about the axes i.e. quadcopter must rotate about either roll, pitch or yaw. Quadcopter has four input forces which are basically the thrust provided by each propeller connected to each rotor with fixed angle. By changing the speeds of the rotors, quadcopter can be moved in any direction.

By changing the pitch angle, the quadcopter can be moved forward (backward) motion by increasing (decreasing) the speed of front (rear) rotor while decreasing (increasing) rear (front) rotor speed. By changing the roll angle, the quadcopter can be moved either left or right. The roll movement is obtained similarly by increasing (reducing) the speed of the right motor while reducing (increasing) the speed of the left motor. The front and rear motors rotate counter-clockwise while other motors rotate clockwise so that the yaw command is derived by increasing (decreasing) counter-clockwise motors speed while decreasing (increasing) clockwise motor speeds. This should be done by keeping the total thrust developed by rotors constant.

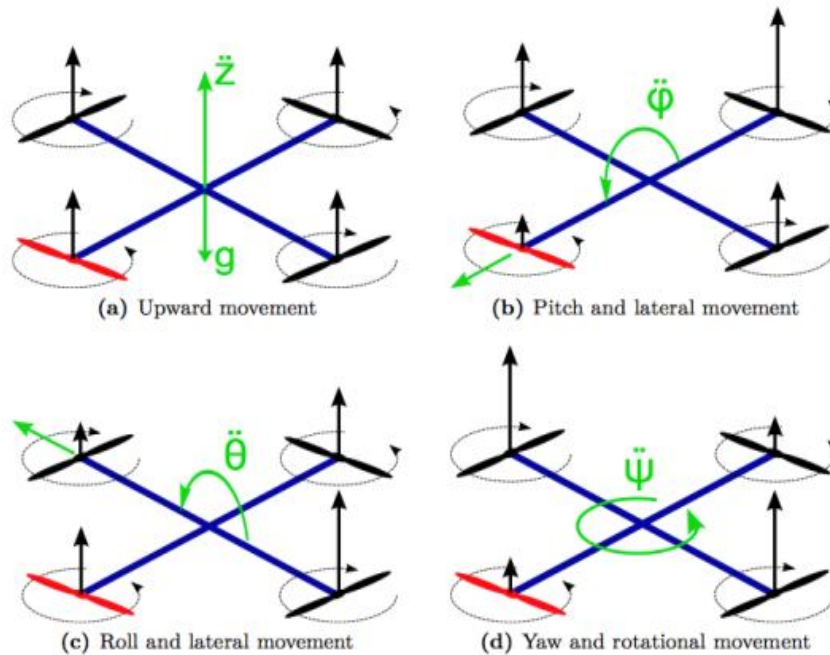

Fig. 1 Scheme of motor speeds for movement of the quadcopter

In order to move the quadcopter from body frame to the inertial frame, the following rotation matrix is used.

$$R = \begin{bmatrix} C_\Psi C_\theta & C_\Psi S_\theta S_\phi - S_\Psi C_\phi & C_\Psi S_\theta C_\phi + S_\Psi S_\phi \\ S_\Psi C_\theta & S_\Psi S_\theta S_\phi + C_\Psi C_\phi & S_\Psi S_\theta C_\phi - C_\Psi S_\phi \\ -S_\theta & C_\theta S_\phi & C_\theta C_\phi \end{bmatrix} \quad \dots (1)$$

Where, $S_x = \sin(x)$ and $C_x = \cos(x)$.

From Newton-Euler equations, the equations of motions of the quadcopter are:

$$\ddot{x} = U_1/m(\sin\Psi\sin\theta + \cos\Psi\cos\phi\sin\theta) \quad \dots (2)$$

$$\ddot{y} = U_1/m(-\cos\Psi\sin\phi + \cos\phi\sin\theta\sin\Psi) \quad \dots (3)$$

$$\ddot{z} = U_1/m(\cos\phi\cos\theta) - g \quad \dots (4)$$

Where x, y, z represent the linear position of quadcopter in the inertial frame.

θ is pitch angle, ϕ is roll angle, Ψ is yaw angle and g is acceleration due to gravity.

The quadrotor dynamic model describing the roll, pitch and yaw rotations contains then, three terms which are the gyroscopic effect resulting from the rigid body rotation, the gyroscopic effect resulting from the propeller rotation coupled with the body rotation and finally the actuators action:

$$I_{xx}\ddot{\phi} = (I_{yy} - I_{zz})\dot{\theta}\Psi - J\dot{\theta}\Omega_r + U_2 \quad \dots (5)$$

$$I_{yy}\ddot{\theta} = (I_{zz} - I_{xx})\dot{\phi}\Psi + J\dot{\phi}\Omega_r + U_3 \quad \dots (6)$$

$$I_{zz}\ddot{\Psi} = (I_{xx} - I_{yy})\dot{\theta}\phi + U_4 \quad \dots (7)$$

Where $\Omega_r = \Omega_2 + \Omega_4 - \Omega_1 - \Omega_3$, is the differential value of rotor differential rotor speed and J is total rotational moment of inertia around the propeller axis.

The control inputs of the quadcopter are the thrust of the quadcopter T and torques around roll, yaw and pitch angles i.e. $\tau_\phi, \tau_\theta, \tau_\Psi$.

The control inputs are represented by U_1, U_2, U_3, U_4

$$U_1 = b(\Omega_1^2 + \Omega_2^2 + \Omega_3^2 + \Omega_4^2) \quad \dots (8)$$

$$U_2 = bl(\Omega_4^2 - \Omega_1^2) \quad \dots (9)$$

$$U_3 = bl(\Omega_3^2 - \Omega_2^2) \quad \dots (10)$$

$$U_4 = d(\Omega_1^2 - \Omega_2^2 + \Omega_3^2 - \Omega_4^2) \quad \dots (11)$$

Where $\Omega_1, \Omega_2, \Omega_3, \Omega_4$ are the speeds of four rotors.

b is lift constant, d is drag constant, l is the distance between the rotor and the centre of mass of the quadcopter.

III.DESIGN OF PD CONTROLLER

In this section designed PD controller to reduce the effect of momentary control inputs on stability of the Quad-rotor to stabilize the quadcopter.

$$e(t) = x_d(t) - x(t) \quad \dots (12)$$

$$u(t) = k_p e(t) + k_d \frac{de(t)}{dt} \quad \dots (13)$$

In the above equation $u(t)$ is input of controller, $x_d(t)$ represents the value of desired state $x(t)$ represents value of present state, and $e(t)$ is the difference between desired state and the present state. k_p is the parameter for proportional and k_d is the parameter for derivative elements of PD controller.

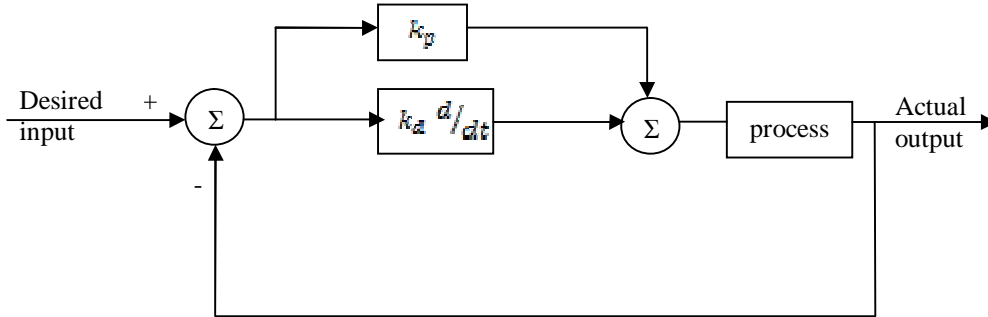

Fig. 2 Block diagram of PID controller

PD controller is designed using the following equations:

$$T = (g + k_{z,D}(\dot{z}_d - \dot{z}) + k_{z,P}(z_d - z)) m / c_\phi c_\theta \quad \dots (14)$$

$$\tau_\phi = (k_{\phi,D}(\dot{\phi}_d - \dot{\phi}) + k_{\phi,P}(\phi_d - \phi)) I_{xx} \quad \dots (15)$$

$$\tau_\theta = (k_{\theta,D}(\dot{\theta}_d - \dot{\theta}) + k_{\theta,P}(\theta_d - \theta)) I_{yy} \quad \dots (16)$$

$$\tau_\psi = (k_{\psi,D}(\dot{\psi}_d - \dot{\psi}) + k_{\psi,P}(\psi_d - \psi)) I_{zz} \quad \dots (17)$$

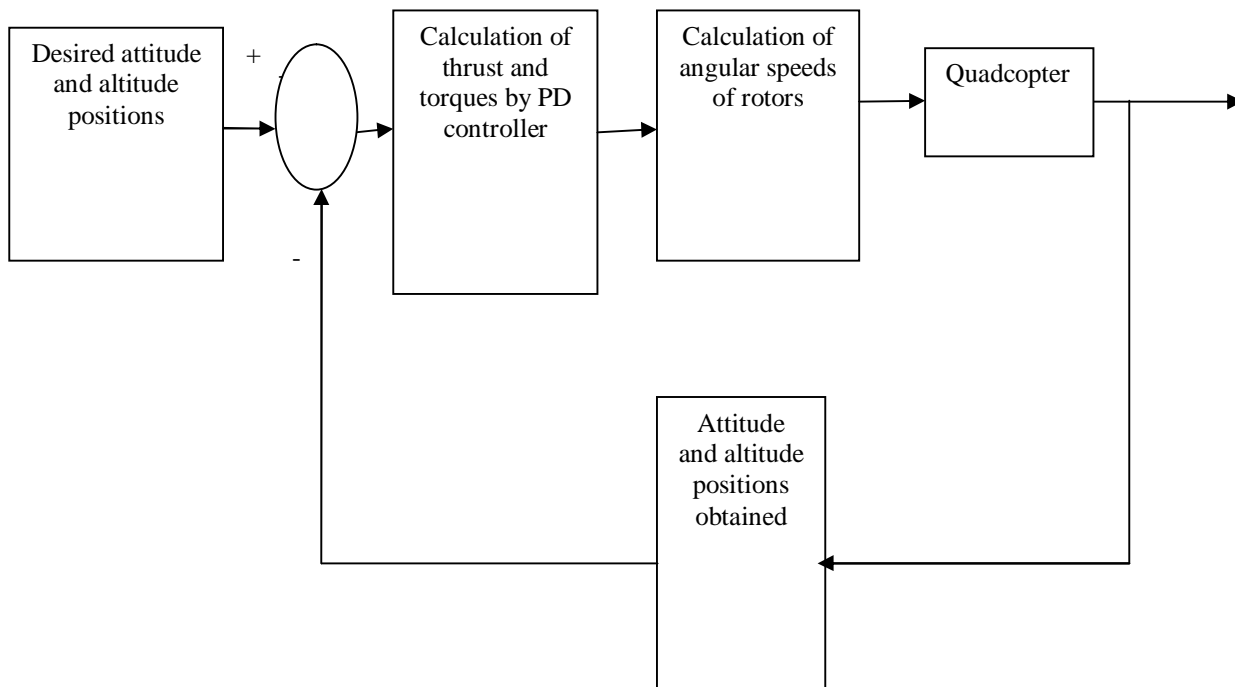

Fig. 3 Block diagram to increase the stability of the Quadcopter using PD controller

IV. DESIGN OF PID CONTROLLER

In this section designed PID controller to reduce the effect of momentary control inputs on stability of the Quad-rotor to stabilize the quadcopter.

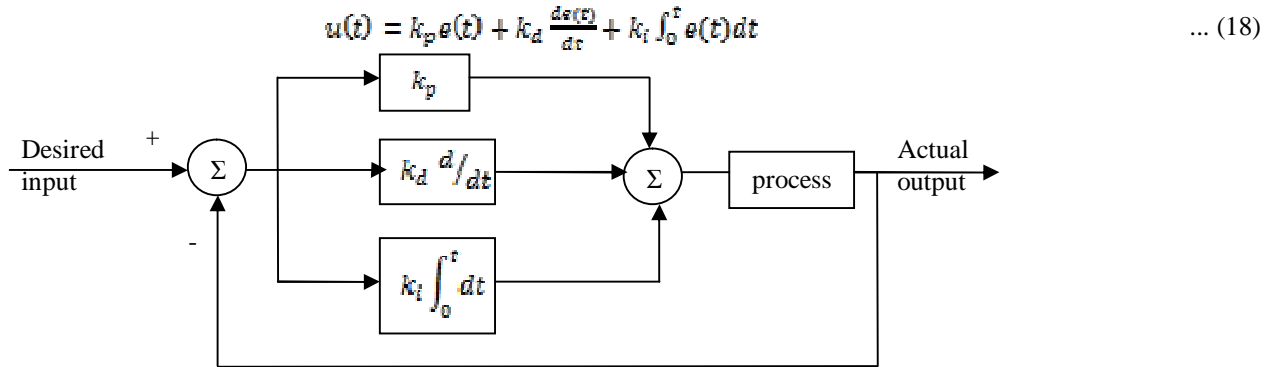

Fig. 4 Block diagram to increase the stability of PID controller

PID controller is designed using the following equations:

$$T = (g + k_{z,D}(\dot{z}_d - \dot{z}) + k_{z,P}(z_d - z) + k_{z,I} \int_0^t (z_d - z) dt) m / c_\phi c_\theta \quad \dots (19)$$

$$\tau_\phi = (k_{\phi,D}(\dot{\phi}_d - \dot{\phi}) + k_{\phi,P}(\phi_d - \phi) + k_{\phi,I} \int_0^t (\phi_d - \phi) dt) I_{xx} \quad \dots (20)$$

$$\tau_\theta = (k_{\theta,D}(\dot{\theta}_d - \dot{\theta}) + k_{\theta,P}(\theta_d - \theta) + k_{\theta,I} \int_0^t (\theta_d - \theta) dt) I_{yy} \quad \dots (21)$$

$$\tau_\psi = (k_{\psi,D}(\dot{\psi}_d - \dot{\psi}) + k_{\psi,P}(\psi_d - \psi) + k_{\psi,I} \int_0^t (\psi_d - \psi) dt) I_{zz} \quad \dots (22)$$

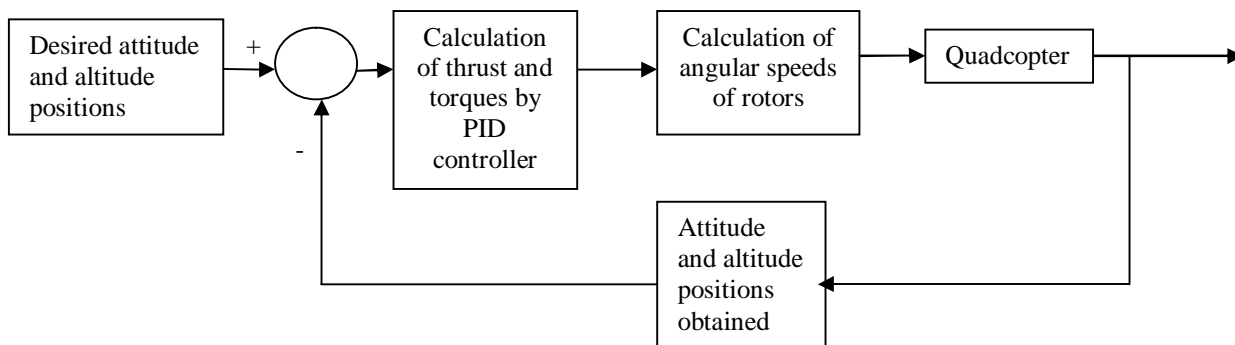

Fig. 3 Block diagram to increase the stability of the Quadcopter using PID controller

In MATLAB, the control inputs of the quadcopter which are the thrust of the quadcopter T and torques around roll, yaw and pitch angles i.e. $\tau_\phi, \tau_\theta, \tau_\psi$ which are represented by U_1, U_2, U_3, U_4 are calculated by the controller using the error between the desired attitude, altitude positions and the obtained attitude, altitude positions. And the corresponding angular speeds of rotors are calculated by using the following equations:

$$\Omega_1^2 = \frac{T}{4b} - \frac{\tau_\theta}{2bI} - \frac{\tau_\psi}{4d} \quad \dots (23)$$

$$\Omega_2^2 = \frac{T}{4b} - \frac{\tau_\phi}{2bI} + \frac{\tau_\psi}{4d} \quad \dots (24)$$

$$\Omega_3^2 = \frac{T}{4b} + \frac{\tau_\theta}{2bI} - \frac{\tau_\psi}{4d} \quad \dots (25)$$

$$\Omega_4^2 = \frac{T}{4b} + \frac{\tau_\phi}{2bI} + \frac{\tau_\psi}{4d} \quad \dots (26)$$

The angular speeds are provided to the quadcopter designed in MATLAB.

V. RESULTS AND SIMULATION

The simulation of mathematical model of quadcopter is implemented in MATLAB simulink. The model is simulated by using the parameter values taken from [9].

Table I
Parameter values for simulation of MATLAB

Parameter	Value	Unit
g	9.81	m/s^2
m	0.65	kg
l	0.23	m
b	$3.13 \cdot 10^{-5}$	—
d	$7.5 \cdot 10^{-7}$	—
J	$6.5 \cdot 10^{-5}$	$kg\ m^2$
I_{xx}	$7.5 \cdot 10^{-3}$	$kg\ m^2$
I_{yy}	$7.5 \cdot 10^{-3}$	$kg\ m^2$
I_{zz}	$1.3 \cdot 10^{-2}$	$kg\ m^2$

In MATLAB simulink, the quadcopter is simulated with two different controllers i.e. PD and PID controllers designed and the step responses of roll, pitch, yaw and z are tabulated as shown in the following table.

Table III
PD and PID Values for Phi, Theta, Psi and Z

Phi						
controller	k_p	k_i	k_d	%overshoot	$t_s(sec)$	$t_r(sec)$
PD	14.69	0	3.32	0	1.24	0.44
PID	9.3046	5.61	3.29	5.52	5	0.34
Theta						
controller	k_p	k_i	k_d	%overshoot	$t_s(sec)$	$t_r(sec)$
PD	14.69	0	3.32	21.87	1.37	0.013
PID	9.81	6.01	3.53	21.07	5.5	0.012
Psi						
controller	k_p	k_i	k_d	%overshoot	$t_s(sec)$	$t_r(sec)$
PD	5.58	0	1.32	3.66	1.2	0.175
PID	3.91	2.39	1.33	2.629	2.4	0.044
Z						
controller	k_p	k_i	k_d	%overshoot	$t_s(sec)$	$t_r(sec)$
PD	0.87	0	9.99	0	2	0.23
PID	2.62	0.15	9.99	2.31	3	0.2

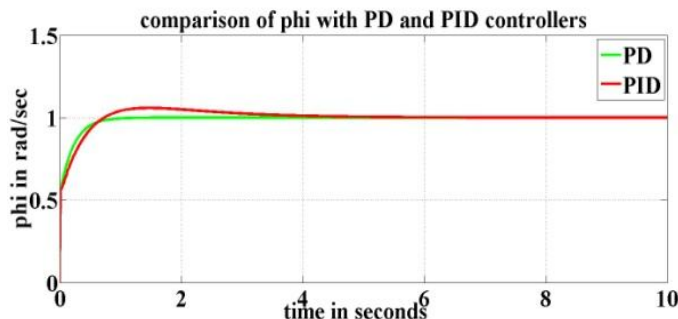

Fig. 4 step response of phi with PD and PID controllers

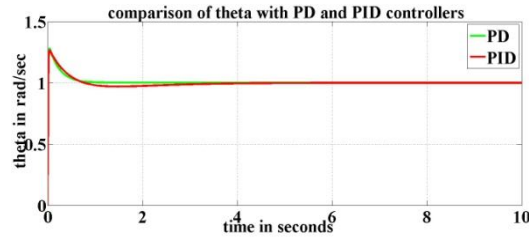

Fig. 5 step response of pitch with PD and PID controllers

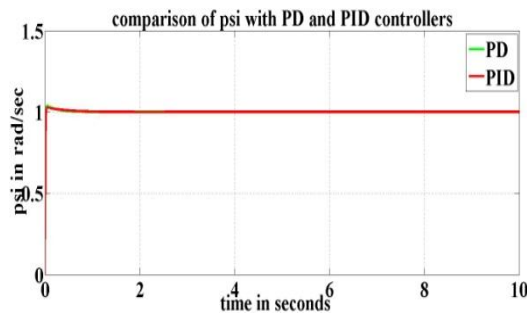

Fig. 6 step response of yaw with PD and PID controllers

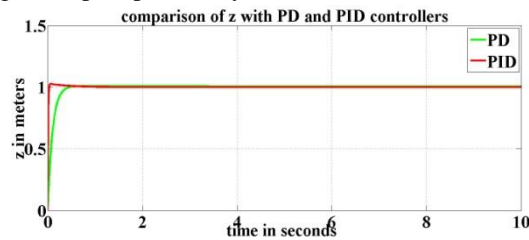

Fig. 7 step response of z with PD and PID controllers

VI. CONCLUSIONS

The P term calculates a proportional response to the error, for example if the quad is tilted a little bit then it can only correct a little bit and does not overshoot the target value, the I controller will ramp up the response if it has not lowered fast enough, which in some cases can be good for example if there is wind and the proportional term is not correcting enough, but that too can cause problems with overshooting the error (requiring a negative error for the same time as there was a positive error), the D controller will dampen the P and I controllers as you get closer to the set point by measuring the rate of change of the system and slowing it as it approaches the set point. Using the PID controller can make the rise time decrease and increases the settling time Using only the P and D controllers can sometimes give better results especially in less demanding environments and can be easier to tune. PD controller works great for multicopters expected to make less aggressive maneuvers where a well tuned PID controller can perform better with very aggressive environments.

REFERENCES

- [1] Jun Li, Yuntang Li "Dynamic Analysis and PID Control for a Quadrotor" 2011 IEEE
- [2] Zaki Mustapa, Shakir Saat, S. H. Husin, Norafizah Abas "Altitude Controller Design For Multi-Copter UAV" 2014 IEEE
- [3] Hamiao Huang, Gabriel M. Hoffman, Steven L. Waslander and Claire J. Tomlin "Aerodynamics and control of autonomous quadrotor Helicopters in Aggressive Maneuvering" 2009 IEEE
- [4] Nengsheng Bao, Xie Ran, Zhanfu Wu, Yanfen Xue, Keyan Wang "Research on attitude controller of quadcopter based on cascade PID control algorithm" 2017 IEEE
- [5] Atheer L. Salih, M. Moghavvemi, Haider A. F. Mohamed and Khalaf Sallom Gaeid "Modelling and PID Controller Design for a Quadrotor Unmanned Air Vehicle" 2011 IEEE
- [6] V. Martinez, "modelling of the flight dynamics of a Quadrotor Helicopter", Dept. Of aerospace sciences. Master of science, Cranfield University, 2007
- [7] Muhammad Arifudin Lukmana, Hendro Nurhadi "preliminary study on unmanned aerial vehicle(UAV) Quadcopter using PID controller" 2011 IEEE
- [8] Gabriel M. Hoffmann, Hamiao Huang, Steven L. Waslander Claire J. Tomlin "Quadrotor Helicopter Flight Dynamics and Control: Theory and Experiment" AIAA Guidance, Navigation and Control Conference and Exhibit
- [9] Samir bouabdallah "design and control of quadrotors with application to autonomous flying"



10.22214/IJRASET



45.98



IMPACT FACTOR:
7.129



IMPACT FACTOR:
7.429



INTERNATIONAL JOURNAL FOR RESEARCH

IN APPLIED SCIENCE & ENGINEERING TECHNOLOGY

Call : 08813907089  (24*7 Support on Whatsapp)