



# **iJRASET**

International Journal For Research in  
Applied Science and Engineering Technology



---

# **INTERNATIONAL JOURNAL FOR RESEARCH**

IN APPLIED SCIENCE & ENGINEERING TECHNOLOGY

---

**Volume: 7      Issue: VIII      Month of publication: August 2019**

**DOI: <http://doi.org/10.22214/ijraset.2019.8023>**

**[www.ijraset.com](http://www.ijraset.com)**

**Call:  08813907089**

**E-mail ID: [ijraset@gmail.com](mailto:ijraset@gmail.com)**

# Heat Transfer Enhancement of a Concentric Tube Heat Exchanger with Circumferential Circular Staggered Fins

Gorli Siva Sai Ram<sup>1</sup>, Ms. K. Vijetha<sup>2</sup>, Prem Kumar Reddy<sup>3</sup>

<sup>1</sup>Student, <sup>2</sup>Guide(M. Tech.), <sup>3</sup>Co-Guide, Department Of Mechanical Engineering, Aditya Engineering College (A), An Autonomous Institution, (Approved by AICTE, Affiliated to JNTUK, Accredited by NBA, NAAC with 'A' Grade), Aditya Nagar, ADB Road, Surampalem

**Abstract:** Heat exchangers are used in industrial process to recover heat between two process fluids. The project carried out on concentric tube heat exchanger having tube with circumferential fins and without fin. The fins were taken in the form of rectangular staggered type arranged in circular way with spacing of 2 mm. The fins were provided on the circumference of inner tube for creating turbulence of hot water. The height and thickness of the fins are 10mm and 0.2mm respectively. Experiment was performed for heat exchanger with fins and without fins. The experiment were performed for different flow rates of hot and cold fluid to evaluate different parameters like Overall heat transfer, Nusselt number, Convective heat transfer coefficient, Pressure drop, friction factor were obtained and compared for simple inner tube and finned tube. Among different experimented cases, the highest nusselt number was obtained is 51.34% more than that of plain tube. Thermo hydraulic performance ( $\eta$ ) =77.6% and performance evaluation criteria is 78.48%. overall heat transfer coefficient of with insert is 1185.032 w/m<sup>2</sup>°c which is 3times more than plain tube.

## I. INTRODUCTION

Heat exchangers are devices that facilitate the exchange of heat between two fluids that are different temperatures while keeping them from mixing with each other. Heat exchangers are the devices which are used for heat transfer between two or more fluids or between a solid particles and fluid which are at different temperatures. Heat exchangers are based on concept that loss of heat on higher temperature side is exactly the same as heat gained in lower temperature side. In this results in decrease of temperature at higher side and increase in temperature at lower side. In heat exchangers the temperatures of fluid keep on changing throughout the tubes. Heat exchangers are commonly used in practice in a wide range of applications, from heating and air-conditioning systems in a household, to chemical processing and power production in large plants. Heat exchangers differ from mixing chambers in that they do not allow the two fluids involved to mix. Heat transfer in a heat exchanger usually involves convection in each fluid and conduction through the wall separating the two fluids. In the analysis of heat exchangers, it is convenient to work with an overall heat transfer coefficient U that accounts for the contribution of all these effects on heat transfer. The rate of heat transfer between the two fluids at a location in a heat exchanger depends on the magnitude of the temperature difference at that location, which varies along the heat exchanger.

## II. LITERATURE SURVEY

- 1) Fehle et al. [1] found the heat transfer behavior of the compact plate fin heat exchanger by applying holographic interferometry. For this, he enabled a non-invasive and inertialess visualization of the temperature field. Then from the constant temperature line at the wall of the temperature field, he determined the local Nusselt number. For determining the effect of corner radii of the heat metal sheets, they first investigated the transfer of heat in plane fin arrangements. They also examined the increase of turbulence by the effect of circular segments in the inclined, non-staggered and staggered arrangements. After the determining the average Nusselt number they got the conclusion that the rate of heat transfer is highest in the in the non-staggered geometry and the staggered geometry achieved the best volume goodness factor.
- 2) Ranganayakulau et al. [2] analyzed the cross flow plate fin, cross flow tube fin, parallel plate fin and the counter-flow plate fin heat exchangers by taking the effect of heat conduction in the longitudinal direction across the heat exchanger wall by using finite element method. They observed that the performance declination of cross flow type heat exchangers is higher compared to the counter-flow and parallel flow heat exchangers for all the cases. This occurrence of the distribution of temperature is two dimensional.

- 3) Sanaye and Hajabdollahi [3] applied  $\epsilon$ -NTU method for the thermal modeling of the compact heat exchanger. By applying  $\epsilon$ -NTU method, they calculated the effectiveness and the pressure drop of the heat exchanger. The fin pinch, height of the pin, offset length of the fin, flow length of the cold stream, no-flow length and flow length of the hot stream are considered as the six design parameters. They used non-dominated sorting genetic algorithm (NSGA-II) for getting the maximum effectiveness and minimum total yearly cost as two objective functions.

### III. DISCUSSION ON CONCENTRIC HEAT EXCHANGER:

The SOLTEQ HE104-PD Concentric Tube Heat Exchanger use the same operating principles as the simplest type of heat exchanger which is the double pipe heat exchanger. One fluid flows through the smaller pipe while the other fluid flows through the annular space between the two pipes. For Experiment A, Experiment B and Experiment D, the hot water flows through the smaller pipe whereas the cold water flows through the annular space between the two tubes.

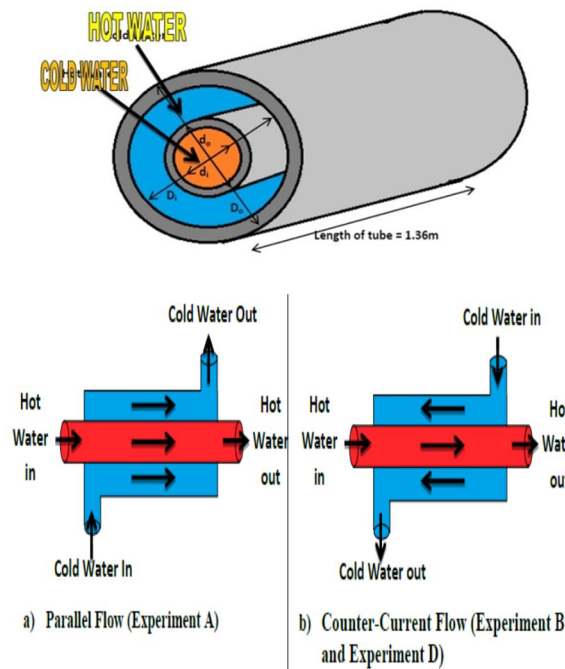

#### A. Discussion on Fins

In engineering community to find new approaches for proposing solutions. Furthermore, the rise in energy consumption has led to formation of many forums and energy management groups to enforce the storage of energy wherever possible in industrial or domestic sectors and in any possible form. It is clear that thermal energy as one of the forms of energy is vastly wasted. Therefore, finding a way to store it has attracted scientists' attention to provide the best method for its storage in a way that it becomes possible to utilize the energy in case of necessity. Storage of thermal energy is divided into two forms. In sensible heat storage systems, there is a proper relationship between the amount of energy and the melting temperature of the material. Alternatively, latent heat is another method for storing thermal energy where the energy storage progresses along with phase change of a substance. In this case of storage, the substance temperature remains constant during the process. Of the two forms, latent heat thermal energy storage (LHTES) technique has features that have been proven to be a better choice. Its advantages include large energy storage capability for a given volume, uniform energy storage because of small temperature gradient, compactness etc. One of the issues that degrades the performance of these systems is their low thermal conductivity which drastically affects the LHTES unit performance. As a result, the rate of melting or solidification of PCM is quiet low. To tackle this problem, since making large-scale LHTES units may not be economical nor practical, it is necessary to improve the thermal performance of the LHTES units. Enhancing techniques for phase change materials can be divided into three categories: (a)employing multiple PCMs improvement of thermal conduction properties of PCM such as blending the PCM with highly conductive particles as in impregnation of the PCM with graphite and extending the heat transfer surface of the heat exchanger, as inencapsulation of PCM use of fins or multi tube systemsHere we propose a novel approach for maximization of the performance of a LHTES unit through the use of innovative fins. The use of extended surfaces by using fins is one of the possible strategies for increasing the rate heat transfer between the PCM and the HTF

in an energy storage unit. The easy installation and low required maintenance during operation are the benefits of using fins compared with the other heat transfer enhancing methods. Fins of heat exchangers can be divided into various types depending on their fin structures.

### B. Types of fins

Fins can be broadly classified as:

1) *Longitudinal Fin*: Longitudinal fins on a tube are best suited for applications where the flow outside the tubes.

Ex

- a) Longitudinal fin – Rectangular profile
- b) Longitudinal fin – Rectangular profile
- c) Longitudinal fin - Trapezoidal profile
- d) Longitudinal fin - Concave parabolic

2) *Radial / Transverse Fin*: Radial fins are normally used for gas flows or turbulent flows and for cross flow type exchangers or shell and tube heat exchangers.

Ex:-

- a) Radial fin: Rectangular profile
- b) Radial fin: Triangular profile

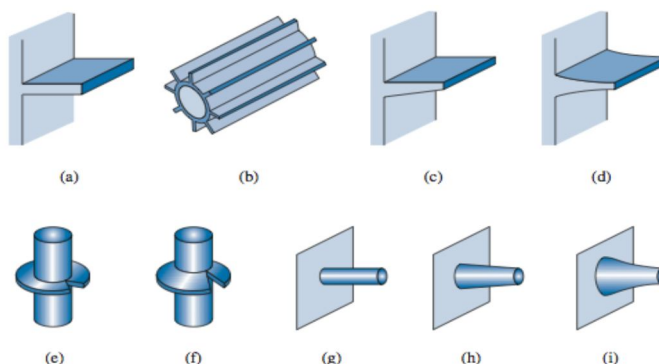

3) *Pin fin*: Pin fins are used to increase heat transfer from heated surfaces to air.

Ex

- a) Pin fin – Cylindrical
- b) Pin fin – Tapered profile
- c) Pin fin – Concave parabolic

### C. Insert Design Specifications

Insert is designed in order to create turbulence in inner tube to increase heat transfer rate in concentric tube heat exchanger.

1) *Fins*

- a) Material – Copper
- b) Thickness - 0.2mm
- c) Overall fins length of span – 1000mm
- d) Fin length - 10mm
- e) Each fin height – 10mm

2) *Outer Tube Specifications*

- a) Material- Mild steel
- b) Outer diameter- 58mm
- c) Inner diameter- 55mm
- d) Thickness- 3mm
- e) Length- 1000mm

3) *Inner Tube Specifications*

- a) Material- Copper
- b) Outer diameter- 27.4mm
- c) Inner diameter- 25.4mm
- d) Thickness- 2mm
- e) Length- 1200mm

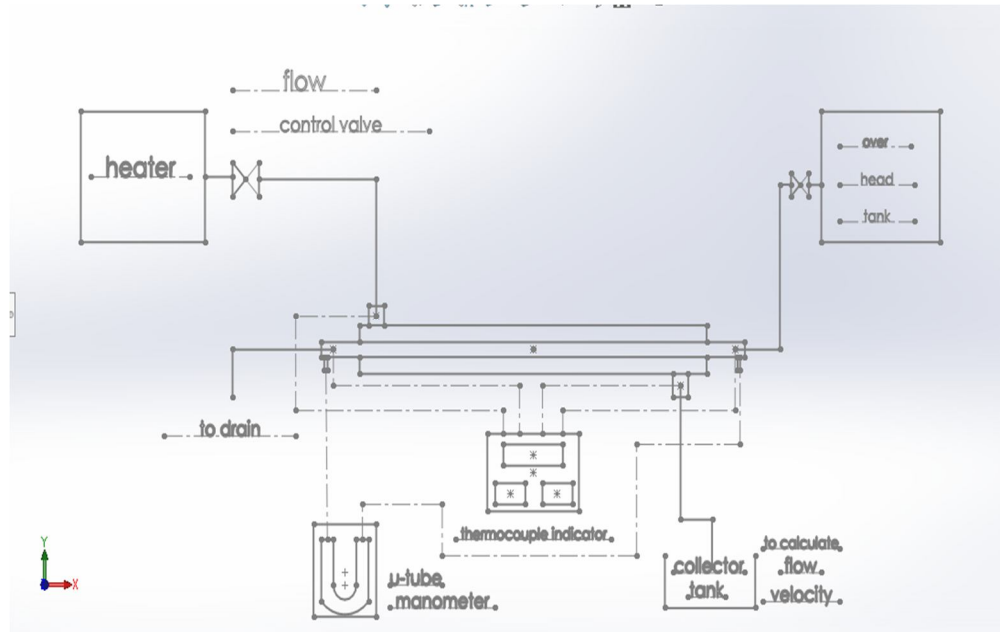

Experimentation setup of concentric tube heat exchanger

#### IV. FABRICATION PROCESS

Initially the design of individual elements and assembly diagrams of concentric tube heat exchanger was done in SOLID WORKS 2018, which are projected in design chapter. The fabrication process was started by constructing a support stand with required dimensions. In order to prepare the concentric tube setup, the outer tube was cut and drilled based on dimensions. In order to regulate inlet and outlet flow two 1 inch pipes are welded at both the ends. Inner tube (copper tube) is made to stand inside the outer tube with the help of flanges which are welded either sides of outer tube. By this process concentric tube setup is done. In order to supply hot water to the experiment geyser is mounted on the supporting stand above the concentric tube setup. PVC and CPVC pipes are fitted either sides of concentric tube setup in order to regulate water flow to concentric tubes.

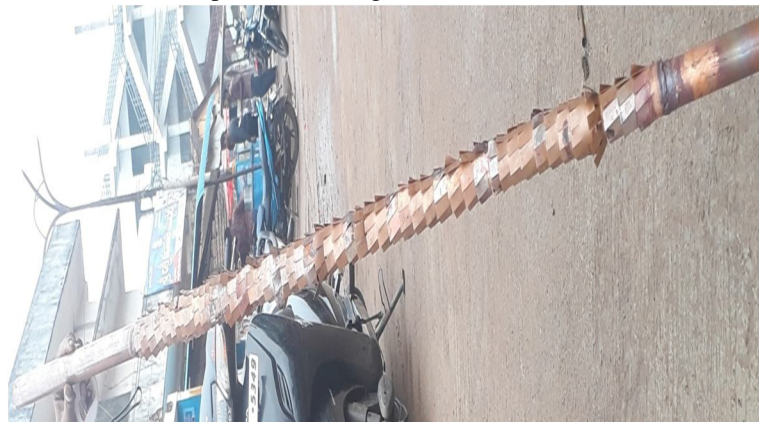

Insert is fabricated with the help of sheet metal work, as a part of insert fabrication copper fins thickness 0.2mm and width 10mm is cut and bent in order to obtain required shape. Insert is fabricated by maintaining uniform width and pitch.



In order to measure change in the temperature thermocouples are installed at both the outlets and inlets. In order to measure mass flow rate small rubber pipes are attached at both the outlet pipes. To avoid leakages M seal's are pasted at various joints.

### V. EXPERIMENTAL SETUP

The important parts of experimental set-up are the test section containing horizontal concentric pipes, u-tube manometers, nipples, thermocouples, electrical heater (geyser) with temperature indicators. All these instruments are selected as per the requirements depending upon their measuring range, accuracy and availability in the market. The test section is made up of copper tubes as it has higher thermal conductivity.

To achieve a particular engineering objective, it is very important to apply certain principles so that the product development is done economically. This economic is important for the design and selection of good heat transfer equipment. The heat exchangers are manufactured in different types, however the simplest form of the heat exchanger consist of two concentric pipes of different diameters known as double pipe heat exchanger. In this type of heat exchanger, one fluid flows through the small pipe and another fluid flows through the space between both the pipes. The flows of these two different or same fluids, one is at higher temperature called hot fluid and another is at lower temperature called cold fluid, can be in same or in opposite directions. If the flows are in same direction then the heat exchanger is called as parallel flow heat exchanger and if the flows are in opposite direction then the heat exchanger is called as counter flow heat exchanger.

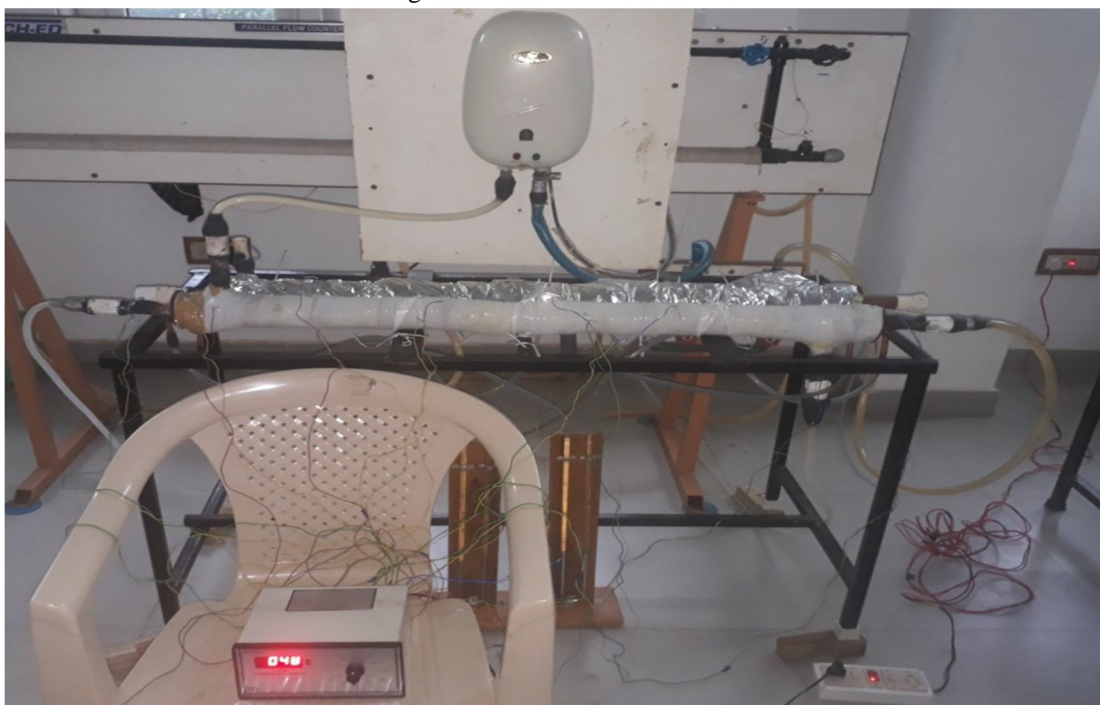

Pictorial image of experimental setup

**VI. PROCEDURE FOR MEASUREMENT:**

- A. Set all the eight thermocouple wires at desired positions (on both inlets, outlets and top surface of the copper tube) to measure the temperature.
- B. Cover the concentric heat exchanger setup with glass wool to provide thermal insulation.
- C. Before starting the experiment check for water leaks and whether all the electrical connections working or not.
- D. By using any water tap water is allowed to flow into tubes and flow rate is controlled by regulating valves.
- E. Hot water enters into outer tube from geyser and at the same time cold water enters inner tube.
- F. Change in temperature at both the inlets and outlets are obtained at temperature indicator.
- G. Mass flow rate is measured by using collection tank method.
- H. Pressure drop is obtained in u tube manometer by checking difference between both the heads.
- I. All readings are taken only after reaching to steady state.

**VII. EXPERIMENTAL READINGS**

Table 2: Plain tube:

Cold water temperature (°c)		Hot water temperature (°c)		Manometer readings (mm)		Mass flow rate (kg/sec)	
Inlet	Outlet	Inlet	Outlet	H1	H2	Inlet	Outlet
31	34	52	50	11	10.8	0.0277	0.0588

Table 2: Tube with fins insert

Cold water temperature (°c)		Hot water temperature (°c)		Manometer readings (mm)		Mass flow rate (kg/sec)	
Inlet	Outlet	Inlet	Outlet	H1	H2	Inlet	Outlet
29	39	61	49	13.25	12.05	0.0277	0.0588

Table 3: Plain tube:

Reynolds number		Nusselt number		Surface heat transfer coefficient		LMTD	Prandtl number	
Hot water	Cold water	Hot water	Cold water	Hot water	Cold water		Hot water	Cold water
971.375	3854.82	8.2791	33.268	129.335	782.882	18.495	3.585	5.355

Table 4: Tube with fins insert

Reynolds number		Nusselt number		Surface heat transfer coefficient		LMTD	Prandtl number	
Hot water	Cold water	Hot water	Cold water	Hot water	Cold water		Hot water	Cold water
1196.766	6606.075	9.932	50.351	155.05	1185.032	20.984	3.771	5.584

### VIII. RESULTS

For comparison of result obtained from the experiment of concentric tube heat exchanger with fin and without fin graphs are plotted between different parameters.

GRAPH 1: Nu vs Re

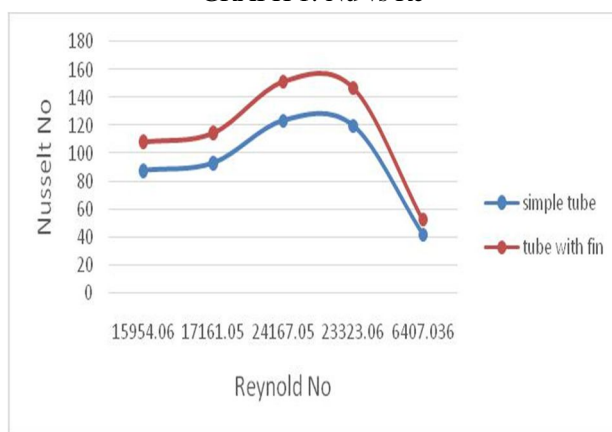

From above graph  $N_u$  vs  $R_e$  we can understand that after using the fins on the tube Nusselt number increase compare to simple tube, which indicate that tube with fin give more convective heat transfer compare to simple tube.

GRAPH 2 : f vs Re

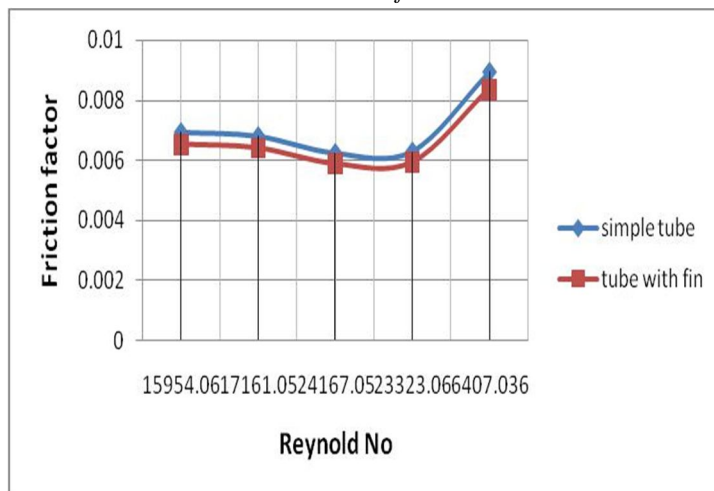

From above graph f vs re we can understand that the friction factor is high for simple tube than tube with fins.



Graph 3 : Pressure drop vs Re

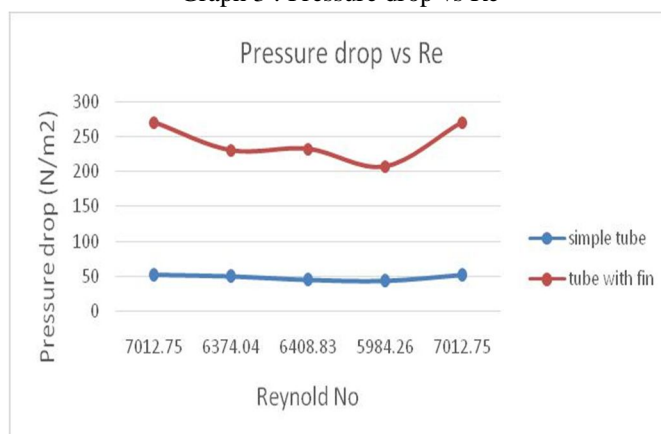

From above graph it is concluded that pressure is increases in fins inserted tube .

### IX. CONCLUSION

In this experiment, a fins insert is proposed for heat transfer enhancement and there heat transfer performance and flow characteristics of insert are studied up numerically. The flow structure and mechanism of heat transfer performance are analysed. The following conclusions are obtained.

- A. As the fluid flows through the fins insert, the cold fluid in core region is rapidly exchanged heat with the hot fluid near the tube well. As a result heat transfer rate increases from 1806.34 W to 4047.388 W.
- B. Besides heat transfer other dimensionless properties such as Reynolds number, nusselt number and friction factor also increases from 1196.766 to 6606.176 and nusselt number increases from 9.932 to 50.351 followed by friction factor from 0.1004 to 0.92871.
- C. By studying all above factors we can conclude that for turbulent flow condition. fins insert offers more heat transfer than plain tube and therefore achieve a high overall heat transfer performance.

### X. FUTURE SCOPE

In the future, heat transfer rate in concentric tube heat exchanger can be increased by changing working fluids such as nano fluids such as nano fluids in the place of water. We used FINS insert but many other different types of inserts can be designed and which can increase the turbulence in specimen which may increase the overall heat transfer coefficient.

### XI. ACKNOWLEDGEMENT

I am thankful to my guide Ms. K.VIJETHA, Professor, who has spared his valuable time. I am indebted to him without whom I would not have successfully completed the project.

### BIBLIOGRAPHY

- [1] G.Vadivel, G.Vijayakumar, An experimental Performance and Analysis of Fin Heat Exchanger , International journal of innovative Research science, Engineering and technology ,vol-4 issue 6,( 2015)
- [2] K. Chang and P. Long, An experimental study of the airside performance of slit fin-and-tube heat exchangers under dry and wet conditions, International Journal of Air- Conditioning and Refrigeration, 17 (1) (2009)
- [3] Ranganayakulu, Ch, and K. N. Seetharamu. "The combined effects of longitudinal heat conduction, flow nonuniformity and temperature nonuniformity in crossflow plate-fin heat exchangers." International communications in heat and mass transfer 26.5 (1999): 669-678.
- [4] K. Torii, K. M. Kwak and K. Nishino, Heat transfer enhancement accompanying pressure-loss reduction with winglet- type vortex generators for fin-tube heat exchanger, International Journal of Heat and Mass Transfer, 45 (2002)
- [5] M. Fiebig, A. Valencia and N. K. Mitra, Wing-type vortex generators for fin-and-tube heat exchangers, Experimental Thermal and Fluid Science. 7 (1993)



10.22214/IJRASET



45.98



IMPACT FACTOR:  
7.129



IMPACT FACTOR:  
7.429



# INTERNATIONAL JOURNAL FOR RESEARCH

IN APPLIED SCIENCE & ENGINEERING TECHNOLOGY

Call : 08813907089  (24\*7 Support on Whatsapp)