



IJRASET

International Journal For Research in
Applied Science and Engineering Technology



INTERNATIONAL JOURNAL FOR RESEARCH

IN APPLIED SCIENCE & ENGINEERING TECHNOLOGY

Volume: 7 Issue: IX Month of publication: September 2019

DOI: <http://doi.org/10.22214/ijraset.2019.9093>

www.ijraset.com

Call:  08813907089

E-mail ID: ijraset@gmail.com

Real Time Smart Grid Load Management by Integrated and Secured Communication: Simulation and Experimental Validation

Megha K. R¹, Abdul Khadar. A²

¹PG Student (Power Electronics), Department of EEE, Ballari Institute of Technology & Management, Ballari, Karnataka-583 104, India

²Associate Professor, Department of EEE, Ballari Institute of Technology & Management, Ballari, Karnataka-583 104, India

Abstract: Request of electrical vitality is expanding step by step. We need better networks to diminish the weight on power framework by making it increasingly solid and verified. Smart Grid (SG) is another innovation towards the customary frameworks because of its two different ways correspondence and multi-highlighted properties. Advanced Metering Infrastructure (AMI) is a key objective towards the modernization of existing sources and a functioning zone of research. AMI assembles the information of dynamic interest, blames in power framework, low voltage profile, charging data and different security alerts. In this paper we proposed a metering system that gathers the constant burden information for intelligent grid and screens the robbery location, line misfortunes in conveyance organize and streamlined planning of sustainable power source assets. In proposed technique we use smart meters having Zigbee convention as Home Area Network (HAN) and data is assembled by control focus at Distribution Transformer that goes about as a nearby control focus. The nearby control focus can send and get data to a remote-control focus for example Ace Data Management Center (MDMC) by means of Neighborhood Area Network (NAN). Every one of the information assembled from various neighborhood control focus by MDMC is dissected and continuous burden information is accomplished. The proposed plan is discovered compelling both in correspondence design and security of the very intelligent grid.

Keywords: Advanced Metering Infrastructure (AMI), Global System for Mobile Communication (GSM), Real Time Load Data Management, Smart Grid, Zigbee.

I. INTRODUCTION

Expanding requests of clients for electrical energy have constrained government to think for elective arrangement. Numerous nations have executed the answer for these issues as Smart Grid (SG). US have first instituted the expression of Smart Grid in 2007. Numerous nations like United States, United Kingdom and China have just introduced these setups and working effectively. One of greatest preferred outlook of SG is fine-granular estimations. It gives remote estimations and made administrator simple burden taking care of. Still it slacks with an issue of protection. Dutch parliament in 2009 has rejected the choice to introduce SG. Thus, these issues ought to be settled without intruding on charging and other burden taking care of issues. Transmission lines are utilized to convey and transmit electrical vitality from creating stations. Power stations go about as focus among age and circulation. It is extremely hard to keep up start to finish correspondence among source and transmitting end since it includes unlimited oversight and Enormous switching control [1]. Security issues, dynamic controls and canny observing are the essential necessities of networks. Secured Communication (SG) moved toward becoming answer for these necessities. Automatic Metering Infrastructure (AMI) is a significant piece of SC that assume key job in the administration of continuous information. The Automatic Meter Reading (AMR) are mounted at customers finishes and data are continually watched in like manner control is moved in best ways and savvy network can answer quick through remote occasions. Moreover, Power framework and correspondence stays on same page for legitimate working.

SC likewise gives the idea of dispersed age. It gave promising reliability and contamination free condition [3]. Strength is additionally a fruitful highlight of appropriated age that is answerable through small creating matrix stations. So as to find blames rapidly these frameworks can be further arrange into sub-networks called smaller scale lattices.

Feature	Previously Used Grid	Smart Grid
Equipment	Electromechanical	Digital
Information Flow	1-way communication	End to End communication
Generation	Integrated generation	Distributed generation
Grid Topology	Radial	Interconnected
Sensors	Less sensors	More Sensors
Observing Ability	Manual	Self
Outage Recovery	Manual	Automatic
Protection Ability	Complicated	Easy
Control Type	Passive Control	Active Control
Testing	Manual check	Remote check
Pollution	High	Low
Overall Efficiency	Low	High
Control Ability	Limited control	Pervasive control
Customer Preference	Few customer choices	Many customer choices

Table: Comparison between existing Grid and future Smart Grid

The remainder of this paper is sorted out as pursues. Area II presents the related work. The keen framework Communication systems are displayed in Section III. Area IV subtleties the proposed model for ongoing burden the executives of savvy lattice. Area V gives the security investigation. Segment VI will finish up this paper

II. IMPLEMENTATION

Numerous frameworks have been proposed for constant and secure correspondence of brilliant network. A few papers and writing have been sought out and think about. A portion of those are related with savvy framework engineering and correspondence conventions, In [6] a capable calculation is intended for legitimate arranging of every hub's correspondence in a multi-jump and multi-channel remote sensor organize. The creators defined the booking issue as far as numerical conditions for the remote sensor organize expected steering topology, and explain these conditions to activity the ideal planning arrangement. Creators in [7] have chacterize Robust Header Compression (ROHC) system is a kind of algorithm to compress the header of various IP packets on savvy matrix. Transfer speed use, low dormancy rate, diminished deferral are its additional attributes. In [8] information estimation has done utilizing various strategies for example Current transformers (CT), sensors and Potential transformers (PT). They made a correlation among IP and CNN and demonstrated CNN as best method. In [10] scientists have managed ongoing correspondence through an effective convention named as MODBUS. In [11] this paper, IPV6 has suggested that help in making association between proposed setup. It don't require application layer that makes its commitment at huge dimension in correspondence field [12]. This paper has utilized a strategy named as DSIPA. It is a light cater gory system which is in charge of assigning IP addresses to hubs in setup. Scientists in [13] have utilized a system of Secure Signal Processing that helps in making the above portrayed issue verified through encryption. So as to make this framework effective, exclusively houses are getting associated with SG. These new associations are making request reaction increased in value. In [15] bidirectional correspondence is finished. Various neighborhood vitality units have introduced which are constrained by ace unit known as Central Energy Management Unit. There will be no individual nearby vitality units. This paper utilizes GSM observing to support correspondence and use Micro controller to make interface. Creators of [16] have experienced correspondence methodology that makes an extension among burden and estimation of information by administrator. It has experienced all issues that ought to be considering in establishment of SG for example segments, devices, and establishment, correspondence and security issues. Parcel of work has been done on SG that outcome in miniaturized scale lattices. Small scale frameworks are really go about as parts of SG. They really work even on intruded on power supply for example at the point when there is no supply from burden side. They have reinforcement system as sustainable power source and non-sustainable power source. They help to serve in territories which are not situated in vicinity to fundamental framework stations. All things considered, these networks are confronting numerous issues as economy, security, requests, establishments and some more. Significant issues that should be taken care of on earnest bases are the board and charging issues. A plan named pair-wide key pre-appropriation plot [17] with one of a kind identifiers are associated with gadgets to make validation exact. Creators of [18] have clarified every one of these focuses and give their view about each and every point. Security issues are further settled by development metering foundation. They help in influencing framework to synchronize further arrangements with exchanging, requests and correspondence issues.

This data is significant for appropriate working and requests of keen network. The proposed system is center for security of keen network. Multi-cast and broadcast can be bolstered by it.

III. PROPOSED METHOD

Continuous information is considered in this paper. To accomplish this AMRs are introduced at client's premises. A stack description is monitored by AMRs continuously to get ongoing information of intensity, current and voltage. At that point it will send this to information organizer which is really a PMD. The capacity of information facilitator is information analyzer and joined the framework through dissemination transformer. In addition, gathering and sending of information from homes which are utilizing this dispersion transformer sent it to information facilitator. In this paper, we have utilized Zigbee to make conceivable communication between information facilitator and AMIs.

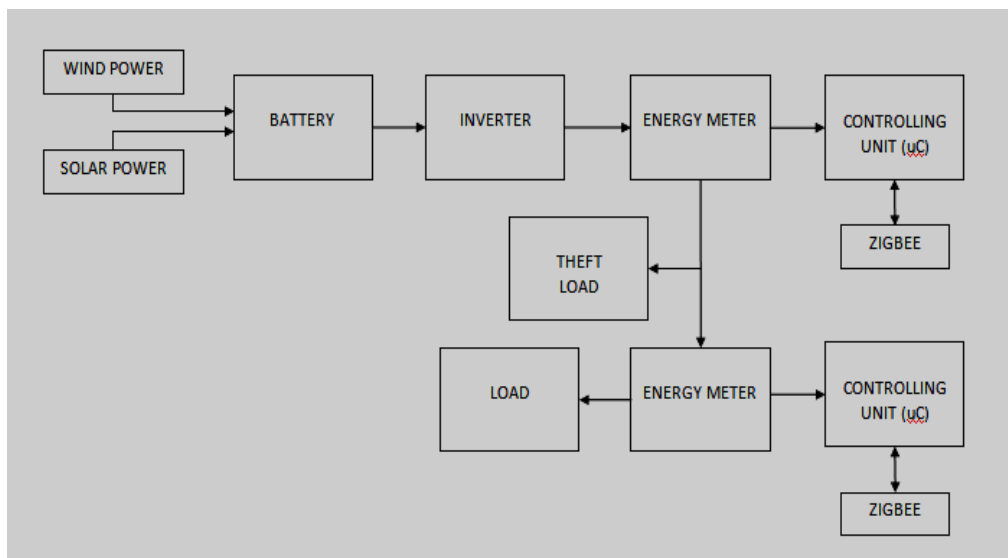

Fig: Proposed system block diagram

IV. HARDWARE SYSTEM

A. Feature of Zigbee.

Zigbee module is a little chip that is microcontroller and appeared. It utilizes Zigbee convention in a communicate organizing model. Zigbee gave promising answers as computerization and broadly utilized in home condition. It can likewise utilize with AMI because of dynamic element in HAN.



Fig: Zigbee module

Unwavering quality, extend, speed, transmission capacity, affectability, and information rate continued by this convention are including characteristics of Zigbee that makes it best choice for the structure of AMI in savvy lattice [22]. Vitality meters are comprised of Zigbee chip and ATMEL microcontroller. This microcontroller is interfaced with a widespread offbeat beneficiary and transmitter. Computerized input is required so a simple to advanced converter is utilized which changes over voltage and current into advanced qualities. Table 2.2 is portraying properties of Zigbee.

V. RESULTS

The proposed system results are as shown below.

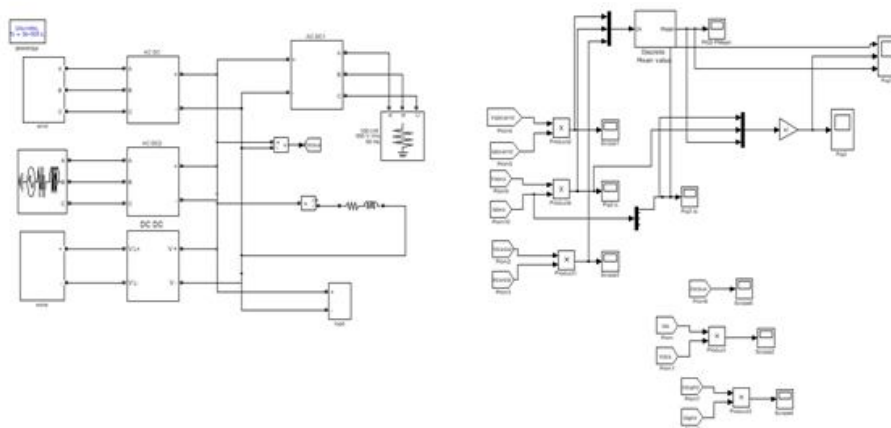

Fig: Simulink designed circuit by using MAT lab software.

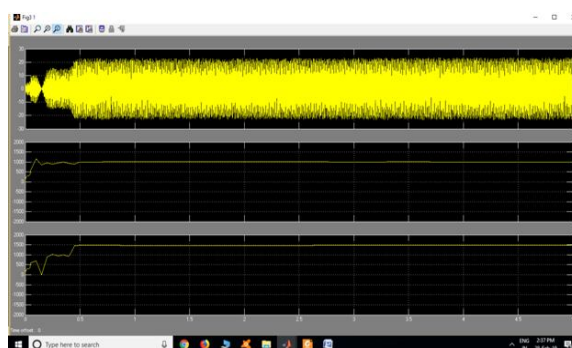

Fig: Simulation circuit results.

The simulation circuit is designed by means of employing the hybrid power generation concept of combined Solar and Wind power, in between an intermediate power plant is designed in order to meet the demand of the consumers during peak load requirements. Also the system is designed with DC – AC convertors and DC – DC convertors for obtaining the desired output parameters. A control circuit is designed in such a way that both analog to digital converter and digital to analog convertors are employed to provide control operation. Hence at the output results we obtain Load Current as first output parameter, second one as Power output parameter and final one as Average Power Output parameter as all these are required to manage the operation of Smart Grid in an most efficient manner.

VI. CONCLUSION

This paper has given a concise diagram on significance of smart grid station and its component. AMI went about as base stone and contributed for SG ongoing burden information the board. It helps in accomplishing ongoing burden information the executives in sharp or smart grids by means of a short range gadget named as Zigbee introduced with AMI. This aides in less utilization of authorized piece of band which thus lessens cost. Since, the proposed framework is a between associated framework and exchanges data starting with one end then onto the next end. Consequently, guarantees security and protection. Additionally, it helps in streamlining of timetable of half breed vitality assets. All data and information utilized in this framework is precise and can help in keeping up bigger frameworks. Results and reproductions have demonstrated the framework dependability and productivity. In future, it very well may be utilized for mechanical and little business regions keeping residential zone include. Working with three zones at any given moment can contribute in this field more.

A. Security

Many organizations apply security strategies that are similar to their existing security models. Some utility security models include segmented and proprietary systems, such as supervisory control and data acquisition (SCADA), newer “open network” systems and interoperability concepts, legacy systems integration, field devices authentication and publicly reviewed standards use.

- 1) *SCADA*: Many technologies involved in SCADA are proprietary and were designed and built over many years. SCADA platforms and security systems have been largely segmented into private networks and often organizations have security strategies that limit access to trusted sources only.
- 2) *Open Network Systems*: A smart grid system is an open network with an infrastructure that must interoperate with different types of devices, data collection points and network protocols. For example, organizations may want to expand the network to include end-user or customer devices to allow customers to be more proactive in monitoring their appliance or energy use. Also, given that smart grid technology is primarily first generation technology, rapid changes and technological evolutions are expected, therefore quick adaptation to new security approaches and technologies will be necessary.
- 3) *Integration of Legacy Systems*: Some principles and lessons learned in IT security can be applied to the smart grid system. The smart grid system, however, has more devices and more diverse devices than a typical IT network. Many legacy devices on these networks have much longer service lives than those of typical IT technologies. A smart grid security design should enable legacy system integration, many of which have only basic communications and security capabilities.
- 4) *Field Device Authentication*: The power grid has millions of field devices that are potentially accessible to unauthorized and perhaps ill-intentioned people. The security design should treat them as a threat until they are authenticated through the network.
- 5) *Publicly Reviewed Standards*: Grid security often assumes that a vulnerability point will be exploited only if its location or access method is widely known. It also often assumes that proprietary non-routable protocols make the grid secure. The opposite is often true. Security methods based on publicly reviewed standards often result in flaws being discovered and resolved more quickly than in proprietary systems.

B. Importance of Power Management

At the core of power management is an understanding of how to effectively optimize energy consumption of each system component. This entails studying the different tasks that your system performs, and configuring each component to ensure that its performance is just right for the job.

- 1) The main motivator for power management is
 - a) reducing overall power consumption to save cost
 - 2) The proper use of power management results in
 - a) heat reduction for servers and computing centers
 - b) reduced secondary costs, including cooling, space, cables, generators, and uninterruptible power supplies (UPS)
 - c) extended battery life for laptops
 - d) lower carbon dioxide output
 - e) meeting government regulations or legal requirements regarding Green IT, for example Energy Star
 - f) meeting company guidelines for new systems

REFERENCES

- [1] E. Hossain, H. Zhu and H. Vincent, “Smart grid communications and networking. Cambridge University Press, 2012.
- [2] S. Goel, Y. Hong, V. Papakonstantinou, and D. Kloza, “Smart grid security”. Springer, 2015.
- [3] M. K. Nigam and a K. Nag, “Compensation of Impacts of Distributed Generation Using Smart Grid Technology”. International Journal of Scientific and Research Publications vol. 3, 2013.
- [4] R. Ma, H.-H. Chen, Y.-R. Huang, and W. Meng, “Smart Grid Communication: Its Challenges and Opportunities,” IEEE Trans. Smart Grid, vol. 4, no. 1, pp. 36–46, 2013.
- [5] X. Fang, S. Misra, G. Xue, and D. Yang, “Smart grid-the new and improved power grid: A survey,” IEEE Commun. Surv. Tutorials, vol. PP, no. 99, pp. 1–37, 2011.
- [6] S. Kumar, H. Lim, H. Kim, and I. Members, “Energy Optimal Scheduling of Multi-Channel Wireless Sensor Networks for Wireless Metering.” Electronics, Information, and Communications (ICEIC), 2016 International Conference on. IEEE, 2016.
- [7] Y. Tsado, D. Lund, and K. Gamage, “Performance of Time-Critical Smart Grid Applications in Narrow Band Power Line Communication,” 7th IET Int. Conf. Power Electron. Mach. Drives (PEMD 2014), pp. 5.2.01–5.2.01, 2014.
- [8] E. Engg and S. Grid, “Design of secure communication protocol for Smart Grid.”



- [9] H. Ohsaki, Y. Nakamoto, N. Yokoi, and H. Moribe, "Performance comparison of IP and CCN as a communication infrastructure for smart grid," Proc. - Int. Comput. Softw. Appl. Conf., vol. 3, pp. 523–528, 2015.
- [10] S. Mohanty, B. N. Panda, and B. S. Pattnaik, "Implementation of a web of things based smart grid to remotely monitor and control renewable energy sources," 2014 IEEE Students' Conf. Electr. Electron. Comput. Sci. SCEECS 2014, 2014.
- [11] M. Chakraborty and N. Chaki, "An IPv6 based hierarchical address configuration scheme for smart grid," Proc. - Int. Conf. 2015 Appl. Innov. Mob. Comput. AIMoC 2015, pp. 109–116, 2015.
- [12] C. Y. Cheng, C. C. Chuang, and R. I. Chang, "Lightweight spatial IP address configuration for IPv6-based wireless sensor networks in smart grid," Proc. IEEE Sensors, 2012.
- [13] E. Zakeriya, et al. "Privacy-preserving data aggregation in smart metering systems: An overview." IEEE Signal Processing Magazine 30.2 (2013): 75-86.
- [14] M. Bayat, S. Keyhan, and R. Alireza, "A unified framework for participation of responsive end-user devices in voltage and frequency control of the smart grid." IEEE Transactions on Power Systems 30.3 (2015): 1369-1379.
- [15] M. F. Khan, et al. "Communication technologies for smart metering infrastructure." Electrical, Electronics and Computer Science (SCEECS), IEEE Students' Conference on. IEEE, 2014.
- [16] D. Brettschneider, et al. "On homomorphic encryption for privacy preserving distributed load adaption in smartgrids." Communications (ICC), IEEE International Conference on. IEEE, 2016.
- [17] A. S. Dobakhshari, A. Sadegh and M. Ali, "Control of microgrids: Aspects and prospects." Networking, Sensing and Control (ICNSC), 2011 IEEE International Conference on. IEEE, 2011.
- [18] A. Kayem, et al. "Key Management for Secure Demand Data Communication in Constrained Micro-Grids." Advanced Information Networking and Applications Workshops (WAINA), 2016 30th International Conference on. IEEE, 2016.
- [19] V. Kumar and M. Hussain, "Secure communication for advance metering infrastructure in smart grid," 11th IEEE India Conf. Emerg. Trends Innov. Technol. INDICON, 2015.
- [20] X. Long, D. Tipper, and Y. Qian, "An advanced key management scheme for secure smart grid communications," 2013 IEEE Int. Conf. Smart Grid Commun. Smart GridComm , pp. 504–509, 2013.
- [21] S. Roy and B. Bedanta, "Advanced Metering Infrastructure for Real Time Load Management in a Smart Grid."
- [22] R. H. Khan and J. Y. Khan, "Wide area PMU communication over a WiMAX network in the smart grid," IEEE 3rd Int. Conf. Smart Grid Commun. Smart Grid Comm, pp. 187–192, 2012.



10.22214/IJRASET



45.98



IMPACT FACTOR:
7.129



IMPACT FACTOR:
7.429



INTERNATIONAL JOURNAL FOR RESEARCH

IN APPLIED SCIENCE & ENGINEERING TECHNOLOGY

Call : 08813907089  (24*7 Support on Whatsapp)