



# IJRASET

International Journal For Research in  
Applied Science and Engineering Technology



---

# INTERNATIONAL JOURNAL FOR RESEARCH

IN APPLIED SCIENCE & ENGINEERING TECHNOLOGY

---

**Volume: 7      Issue: X      Month of publication:      October 2019**

**DOI:      <http://doi.org/10.22214/ijraset.2019.10032>**

**[www.ijraset.com](http://www.ijraset.com)**

**Call:       08813907089**

**E-mail ID: [ijraset@gmail.com](mailto:ijraset@gmail.com)**

# Design and FEA Analysis of Boiler Chimney against Fouling

Priyanka Thigale<sup>1</sup>, Prof. R. K. Nanwatkar<sup>2</sup>

<sup>1</sup>PG Student, <sup>2</sup>Asst Professor, Department of Mechanical Engineering, NBN Sinhgad School of Engineering, Ambegaon (Bk), Pune, India.

**Abstract:** Chimney plays very important role in the exhaust of flue gases from boiler to the atmosphere. An initial design of chimney heat recovery heat exchanger was provided. Generally, boiler is a closed vessel in which fluid (water) is heated. A chimney is nothing but a simple structure used for carrying hot flue gases from stove, furnace to the atmosphere. It causes heat losses in many ways in such a way that the discharge of hot combustion gases to the atmosphere through chimneys. This Paper focuses on an initial design of chimney for 15 TPH boiler, 15 bar pressure is provided. Design against Fouling is mainly Focused in this work for reducing discharge of hot combustion gases and an attempt is made to improve the Efficiency of Boiler. The main objective of this project is to redesign the chimney to reduce the formation of fouling which drastically affects the efficiency of boiler. An experimental analysis using FEA is done by using ANSYS and same is validated with actual solution by customer end.

**Keywords:** FEA, boiler, chimney, fouling, cyclic loads, creosote

## I. INTRODUCTION

At the point when hot vent gases goes from a flame through cylinders then this sort of heater are called as flame tube boilers. In this sort warmth is moved from the dividers of the cylinders by methods for conduction mode, accordingly when water is warmed it is changed over to the steam. The benefits of this sort of evaporator is, there are numerous little cylinders or pipes henceforth it offer huge warming surface territory.

A fireplace is basic structure where hot vent gases are conveyed to the environment from heater. Along these lines it results heat misfortunes with the end goal that fireplace conveys hot pipe gases to climate. By and large vertical fireplaces are utilized, with the goal that progression of gases should take easily, and to draw the air into the burning is known as smokestack impact. The space inside the fireplace is called as vent. By and large fireplaces are situated in structures, s trains and ships as well. Alluding to train stacks or ship fireplaces, the term smokestack is utilized. The capacity to move pipe gases to the environment because of smokestack impact is know as fireplace impacts. Fouling is only the affidavit of undesirable material on surfaces because of this aggravation happens in capacity of part. Fouling material additionally comprise of inorganic or non-natural substance . Fouling is normally not quite the same as surface-development wonders, in this it can happen on a surface of a segment, framework which plays out the capacity. Because of vaporization of inorganic components like coal during burning can cause fouling. At the point when the components stored on the outside of part because of warmth is consumed and temperatures decline in the convection zone of the heater, and in this way mixes shaped from this.

Store development, encrustation, crudding, statement, scaling, scale arrangement, slagging, and muck development are different terms which can be utilized to portray fouling . This Fouling are normally found in ship frames and so forth. In warmth move parts fouling happens because of salts present in the cooling water or gases, and in this way the math is create on teeth . There are two fundamental sorts of fouling full scale fouling and small scale fouling which are utilized in the cooling innovation and other specialized fields. In this way Micro fouling is increasingly hard to counteract.

Types of Fouling

- A. Crystallization fouling.
- B. Particulate fouling.
- C. Biological fouling.
- D. Reaction fouling.
- E. Freezing fouling.
- F. Corrosion fouling.

## II. LITERATURE SURVEY

Ulrich Kleinhansa, Christoph Wielanda, Flemming J. Frandsenc, Hartmut Spliethoffa,b in ELSAVIER journal of Progress in Energy and Combustion Science, in paper entitled (4 February 2018), "Ash formation and deposition in coal and biomass fired combustion systems: Progress and challenges in the field of ash particle sticking and rebound behavior" survey the present learning on powder development, fiery remains molecule transport and statement during strong fuel ignition, with accentuation on molecule staying and bounce back conduct. A piece of the fuel can be inorganic, this structures inorganic vapors and fiery debris particles. The impaction of strong, liquid or mostly liquid particles on surfaces is subject to the molecule and surface qualities. For example, a particulate store may catch approaching particles or be evacuated because of disintegration, while liquid layer will gather all affecting particles, regardless of in the event that they are sticky or not. The fundamental properties influencing the molecule stickiness are the consistency and surface strain for silicate-rich fiery remains. On other hand, the stickiness of salt-rich slag for herbaceous biomass and wood-or waste-based fills is regularly portray by utilizing the fluid soften part. The critical parameters, for example, the molecule motor vitality and the edge of impaction. In the event that all active vitality is dispersed during the effect, the molecule will stay superficially. This audit exhibits a review of significant cinder shaping components found in biomass and coal, and talks about the heterogeneity of particles' inorganic structure. Systems, for example, Ash transportation and affidavit likewise their scientific depiction are talked about. Likewise arrangement and temperature-depended models are given for the estimation of fiery debris molecule and store properties. These properties are basic so as to portray the molecule staying and bounce back conduct. Fiery remains molecule staying and bounce back criteria can be isolated into three fundamental gatherings, they are as per the following:

- A. The particle melt fraction,
- B. The particle viscosity, or
- C. The energy dissipation of a particle

Staying criteria are displayed, their required parameters are talked about and normal molecule and surface properties found in burning frameworks are outlined. Eight diverse staying criteria are executed in a computational liquid elements code and calculations are analyzed against estimations from an entrained stream reactor. Uniform estimated soft drink lime glass particles are connected rather than inhomogeneous fly powder particles, since soft drink lime glass is known to carry on like coal fly slag. By utilizing a foundation dependent on crafted by Srinivasachar et al best understanding for the affidavit rates on a perfect cylinder is accomplished. In this model, the staying and bounce back limit is a component of the molecule dynamic vitality, the edge of impaction, and, the molecule consistency. Hence, the parameter, for example, silicate-rich fiery debris are utilized to affirmed the molecule consistency. It ought to be determined utilizing temperature-and sythesis subordinate connections, staying alert that there is a huge dispersing in the outcomes from such models and that the models are regularly just substantial in restricted compositional ranges, and can't be utilized outside these. An unthinking model is utilized to clarify results from glass molecule tests and their reliance on the molecule motor vitality. Accordingly, the impaction procedure is subdivided in four stages, and the vitality dispersal of each progression is determined. These hypothetical contemplations demonstrate that the contact edge of a liquid bead with the substrate is of minor significance, and that most of saving particles are commanded by crafted by disfigurement against thickness. This audit passes on the its exact forecast for silicate-rich fiery debris and significance of the molecule consistency. The proposed standard can anticipate the staying of little, strong particles underneath 10 mm distance across, as it is frequently seen in writing. Additionally, it is urgent to think about the surface structure and stickiness, so as to foresee testimony rates in strong fuel-terminated frameworks. Because of various fiery remains molecule science, biomass cinders and their stickiness are progressively troublesome, when contrasted with coal powder. And furthermore salt-rich particles and their stickiness are control. Here, a connection between the consistency and measure of fluid stage is a promising methodology, and ought to be tended to in future work. Moreover, the thickness of various cinder particles silicate-, salt-or Ca-rich ought to specially be demonstrated from the concoction and physical structure rather than an exact fitting strategy between fuel science and consistency estimations:<sup>[1]</sup>

Akash Singh, Vivek Sharma, Siddhant Mittal, Gopesh Pandey, Deepa Mudgal, Pallav Gupta in Springer International Journal of Industrial Chemistry (2018) in paper entitled, "An overview of problems and solutions for components subjected to freside of boilers" examined different reports including issues, (for example, agglomeration, slagging, fouling, burning embrittlement, weariness disappointment and high temperature erosion) identified with boilers and their potential arrangements. Likewise a portion of the controlling parameters for high temperature erosion has additionally been examined. For the improvement in surface Thermal splashing is utilized as a primary device. By utilizing diverse covering systems and materials issue of erosion, wear opposition,

electrical or warm protection can be changed. What's more, consequently because of testimony of fiery remains in biomass-terminated boilers additionally causes serious issues of agglomeration. By utilizing kaolin or  $NH_3$  in the bed of boilers this issue of agglomeration can be comprehended. Heartbeat explosion wave innovation, savvy ash blower, and synthetic treatment innovation are some significant procedures which can be utilized to limit the impacts of fouling. They found that Corrosion hindrance is one of the strategies that have been utilized to secure and build the life of metallic social legacy. Sol-gel defensive coatings on the metal and combinations surfaces can diminish the rate of consumption in different destructive mediums. <sup>[2]</sup>

Ming-Jia Li, Song-Zhen Tang, Fei-long Wang, Qin-Xin Zhao, Wen-Quan Tao, in ELSEVIER journal, (2017) titled, "Gas-side fouling, erosion and corrosion of heat exchangers for middle/low temperature waste heat utilization: A review on simulation and experiment" condensed the trial studies, improvement and incitement for the fouling, disintegration and erosion of warmth exchangers. The key instruments, the forecast models and techniques, important examinations of fouling, disintegration and erosion the reproductions with these models were presented. Furthermore, the expectation procedures of the fouling, disintegration and erosion rate were presented by accepting creators' examinations as delineations among them. At long last, it ought to be noticed that for the fouling, disintegration and consumption issues, there are still some key attempts to be improved comprehend the fouling, disintegration and erosion components, and propose the novel warmth exchangers for hostile to fouling, against disintegration and hostile to consumption. In future warmth exchanger structures can beat the issues. Hence This will advance the advancement of advances which can proficiently recuperate the hot pipe gas waste warmth and therefore by and large vitality use productivity is improved.

### III. PROBLEM IDENTIFICATION

The need to make proficient boilers in heater industry is significant in view of up and coming new innovations. Various parameters ought to be chosen for proficient working for kettle. Because of various warmth misfortune happening in the evaporator the exhibition of heater gets influenced. The unburnt pipe gases get aggregated on the smokestack surface and this structures a layer of on surface, this is called as fouling and this issue accompanies organization. Subsequently, in view of fouling on surface its warmth move rate diminishes and accordingly the effectiveness of evaporator changes. So to beat this issue we have make a unique arrangement with the goal that warmth lost through vent gases while leaving stack stage may produce a thought of fouling results. Consequently by expanding the speed of the vent gases this issue can be diminished. So we have to make an arrangement for expanding the speed of pipe gases

#### A. Objectives

- 1) The main objective of this project is redesigning and testing of boiler chimney to reduce fouling but also not to affect efficiency.
- 2) An attempt is made by material modification and by introducing flappers in the fifth section of the chimney. Flappers were properly installed at various angles like  $10^\circ$ ,  $12^\circ$ ,  $15^\circ$  and results analyzed by comparing all of them.
- 3) Material modification by selecting material which can reduce the chances of fouling.
- 4) Design modification of chimney by introducing the flappers and verification of the same through FEA and validating it with actual results given by customer end.

#### B. Scope

- 1) In this project, an initial design of chimney for 15 TPH boiler, 16 bar pressure is provided.
- 2) This project is based on the work undertaken to redesign the flue gas duct in chimney to reduce the formation of fouling which affect the efficiency of the boiler.
- 3) This system was specifically designed for boiler chimney. In the completion of the design, the flappers are provides in the flue gas duct (segment V).
- 4) The attempt of project is to reduce the cross section area in that particular segment to increase the flow of flue gases.

#### C. Methodology

- 1) The project is proposed to be done in the following manner.
- 2) Compiling the problems, difficulties arise in boiler system which causes reduction in boiler efficiency.
- 3) Research on fouling in boilers & its effect on boiler efficiency.
- 4) Research on ways of minimizing fouling.
- 5) Finding out the best way to change the design to reduce fouling problems.

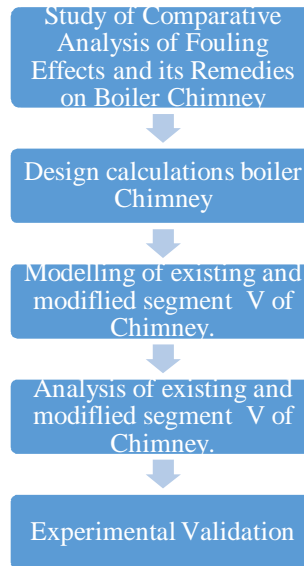

Fig. No. 1: Flowchart of methodology

#### IV. DESIGN AGAINST FOULING

It was our duty to consider the effect of fouling upon the component performance during the specific operation lifetime and make provisions in our design for sufficient extra capacity to ensure that the exchange will meet process specifications up-to shut down for cleaning. We were also to consider the mechanical arrangements that are necessary to permit easy cleaning. In our design, the following measures have been taken to reduce the rate of fouling.

- A. Provision for particulate filters.
- B. Introduction of turbulent flow upstream of the exchanger core

#### V. BOILER SPECIFICATION

Boiler steam capacity	15 TPH
Working steam pressure	15 bar
Fuel	Coal
Fuel firing rate	2023 kg/hr
Steam generation rate	8954 kg/hr
Steam pressure	14 bar
Feed water temperature	90°C
% Of co <sub>2</sub> in flue gases	8%
% Of co in flue gases	167
Average flue gas temperature	210 °C
Ambient temperature	027 °C
Humidity in ambient air	0.018kj/kg of dry air
Surface temp of boiler	65 °C
Wind velocity around boiler	4 m/sec
Total surface area of boiler	118 mm <sup>2</sup>
G cv of bottom ash	700 K.cal/kg
G cv of fly ash	395 k.cal/kg
Ratio of b. A/ f.a	90;10
Fuel analysis in %	
Ash content in fuel	7.80%
moisture in coal	29%
carbon content	38%

Table No. 1 : Boiler Specification

**VI. DESIGN CALCULATION**

**A. Data Required For Design Calculation**

	Top diameter (in mm)	Bottom diameter (in mm)	Height (in mm)	Shell thickness (in mm)	Avg. diameter (in mm)
Seg 1	900	900	5000	6	900
Seg 2	900	900	5000	6	900
Seg 3	900	900	5000	6	900
Seg 4	900	900	5000	8	900
Seg 5	900	1575	5000	10	1237.5
Seg 6	1575	2250	5000	10	1912.5

Table No. 2 : Data required for design calculation

**B. Basic Dimensions of Chimney**

Total height of chimney = 30m

Height of flare = H = 1/3(30) = 10 m

Diameter of the flare = 1.6x0.9 = 1.44m.

Computation of wind pressure:

The design wind speed at any height z is given by

$$V_z = V_b \cdot k_1 \cdot k_2 \cdot k_3$$

Where,

V<sub>b</sub> = basic wind speed at the site = 37m/s for Pune.

k<sub>1</sub> = probability factor (risk coefficient) = 1.0 for general buildings and structures.

k<sub>3</sub> = topography factor = 1.0 for flat topography

k<sub>2</sub> = terrain, height and structure size factor

$$V_z = 37 \times 1 \times 1 \times k_2$$

Now design wind pressure P<sub>z</sub> = 0.6V<sup>2</sup>

$$= 0.6 \times (37 \times k_2)^2 \times 10^{-3} \text{ kN/m}^2$$

$$= 22.2 k_2 \text{ KN/m}^2$$

For chimney, adopting a shape factor of 0.7, f<sub>z</sub> = (P<sub>z</sub> · D · Δ<sub>z</sub>) 0.7.

**C. Calculation Of Wind Speed Pressure and Force For Each Segment**

Segment	H(m)	k <sub>2</sub>	D (m)	Δ <sub>z</sub>	P <sub>z</sub> = 1.3245 k <sub>2</sub> <sup>2</sup> (kN/m <sup>2</sup> )	f <sub>z</sub> = (p <sub>z</sub> · D · Δ <sub>z</sub> ) 0.7 (KN)
Seg 1	30	1.10	0.9	5	1.6037	5.0517
Seg 2	25	1.062	0.9	5	1.4962	4.1713
Seg 3	20	1.05	0.9	5	1.4612	4.6029
Seg 4	15	1.02	0.9	5	1.3789	4.3468
Seg 5	10	0.98	1.2375	5	1.2729	5.5132
Seg 6	5	0.98	1.9125	5	1.2729	8.5205

Table No. 3 : Calculation of wind speed pressure and force for each segment

**D. Moment at Each Section**

Moment at segment 1=(5.0517 x 2.5)  
=12.6292 KN-m

Moment at segment 2=(5.0517 x 7.5)+(4.1731x2.5)  
=49.6705 KN-m

Moment at segment 3=(5.0517 x 12.5)+(4.1731x7.5)+ (4.6029x2.5)  
=110.0017 KN-m

Moment at segment 4=(5.0517 x 17.5)+(4.1731x12.5)+ (4.6029x7.5)+(4.3436x2.5)  
=192.6992 KN-m

Moment at segment 5=(5.0517 x 22.5)+(4.1731x17.5)+ (4.6029x12.5)+(4.3436x7.5)+(5.5132x2.5)  
=300.0387 KN-m

Moment at segment 6=(5.0517 x 27.5)+(4.1731x22.5)+ (4.6029x17.5)+(4.3436x12.5)+(5.5132x7.5)+(8.5205x2.5)  
= 442.4625 KN-m

**E. Design of Chimney Shell**

Stress due to chimney weight,

$f_s=0.0785h \text{ N/mm}^2$

Stress due to weight of lining,

$f_l=0.002h/t \text{ N/mm}^2$

Stress due to wind,

$f_w=(0.004M_w x x)/(\pi D^2 t) \text{ N/mm}^2$

Minimum thickness of shell from stability point of view= $D/500$

$=900/500 =1.8 \text{ mm.}$

It is assumed that the design life of steel chimney shell will be 20 years and coal is used for boiler. Hence add additional 4mm Thickness to account for corrosion, Hence total minimum thickness of plate= $6+4=10\text{mm.}$

Effective thickness = $10-4=6\text{mm}$

$f_c$  = the maximum compressive force per unit length

$f_t$  = Maximum uplift force per unit length of circumference

**F. Determination of Stress**

Seg	h(m)	D(m)	T(mm)	D/t(mm)	h/D	$f_c \text{ (N/mm}^2\text{)}$	$f_t \text{ (N/mm}^2\text{)}$
1	5	0.9	6	150	5.55	124	105
2	10	0.9	6	150	11.11	124	105
3	15	0.9	6	150	16.66	124	105
4	20	0.9	8	112.5	22.22	108	105
5	25	1.2375	10	123.75	20.20	108	105
6	30	1.9125	10	191.25	25.1572	97	105

Stress due to chimney weight (fs)	Stress due to weight of lining (fl)	Stress due to wind (fw)	Fc max	Ft max	Stability check
0.3925	1.666	3.308	5.366	2.9155	stable
0.785	3.333	13.102	17.130	12.227	stable
1.1775	5	28.818	34.996	27.641	stable
1.57	5	37.86	44.43	36.29	stable
1.9625	5	24.94	31.908	22.977	stable
2.355	6	15.4022	23.757	13.047	stable

Table No. 4 : Determination of stress

### G. Computation of Actual Weight

Self Weight of chimney

$W_s = \text{Density of steel (78.5kN/m}^3) \times \text{Volume of steel in chimney}$

$$W_s = 3(78.5 \times \pi \times 0.9 \times 0.006 \times 5) + (78.5 \times \pi \times 0.9 \times 0.008 \times 5) + 2(78.5 \times \pi \times (0.9+2.250/2) \times 0.010 \times 5) = 67.6949 \text{ KN}$$

$W_l = \text{Weight density for brickwork} = 20 \text{ KN/m}^3$

$$= (20 \times 0.8 \times \pi \times 0.1 \times 20) + (20 \times \pi \times (0.8+2.150/2) \times 0.1 \times 10) = 193.207 \text{ KN}$$

$$\text{Total } W = 67.6949 + 193.207 = 241.482 \text{ KN}$$

Increase the weight by 5% to account for lap, stiffeners, platforms, ladder etc.

$$\text{Total } W = (241.482 + 12.074) = 253.556 \text{ KN}$$

### H. Design of Base Plate

The maximum compressive force per unit length

$$F_c = \frac{W_s + W_l}{\pi d} + \frac{4M_w}{\pi d^2 \cdot 2} = \left[ \frac{253.5568}{\pi \times 2.250} + \frac{4(442.4625)}{\pi \times 2.250^2} \right]$$

$$= 147.1520 \text{ KN/m}$$

$$= 147.1520 \text{ N/mm}$$

Allowable bearing pressure,  $\sigma_c = 4 \text{ N/mm}^2$

$$\therefore \text{Width} = 147.1520 / 4$$

$$= 36.788 \text{ mm}$$

Provide 37 mm wide base plate.

### I. Design of Anchor Bolts

Maximum uplift force per unit length of circumference

$$F_t = \frac{4M_w}{\pi d^2} - \frac{W_s}{\pi d}$$

As per IS 6533 (part 2): 1989, the overturning moment  $M_w$  should be increased to 1.5 times from stability consideration

$$F_t = \frac{4(442.4325 \times 1.5)}{\pi \times 2.250^2} - \frac{67.6949}{\pi \times 2.250}$$

$$= 365.99 \text{ KN/m}$$

Let us provide 39mm dia. ISO fine threaded bolts having effective area =  $1028 \text{ mm}^2$ , at root of thread. Taking permissible tensile strength of  $120 \text{ N/mm}^2$  at the root of thread.

$$\text{Strength of each bolt} = 1028 \times 120 \times 10^{-3} = 123.36 \text{ KN.}$$

No increase in stress is recommended since wind is the major load in the case of chimneys.

$$\text{Spacing of bolts} = \frac{123.36}{67.6949} \times 1000 = 1822.2 \text{ mm}$$

$$\text{No. of bolts} = \frac{\pi \times 2.250 \times 1000}{1822.2} = 3.8791$$

However, provide 4 bolts of 39mm nominal diameter on a circle diameter.



### VII. FINITE ELEMENT ANALYSIS OF EXISTING MODEL OF SEGMENT V OF CHIMNEY

#### A. Reverse Engineering of Existing Model of Segment II of Chimney

The below CATIA diagram represents segment II of the chimney which we have taken into consideration. The section V is of 5000mm high with base diameter of 1572mm and outer diameter of 900mm.

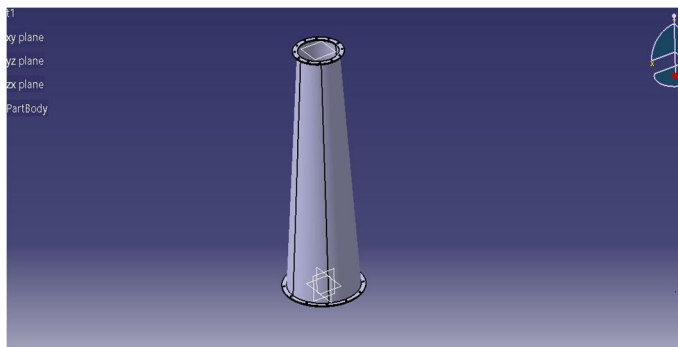

Fig. No. 2: CAD model of segment V

#### B. Finite Element Analysis Of Existing Model Of Segment V Of Chimney

1) *Mesh Model:* A structure or component consists of infinite number of particles or points hence they must be divided in to some finite number of parts. Meshing is nothing but dividing a component into finite numbers. Dividing components helps us to carry out calculations on the meshed part. We divide the component by nodes and elements. We are going to mesh the components using 3D element. Number of nodes and elements are formed respectively. After meshing elements are to be checked for Quality i.e. elements have a definite quality criterion and this criterion should be met by all elements.

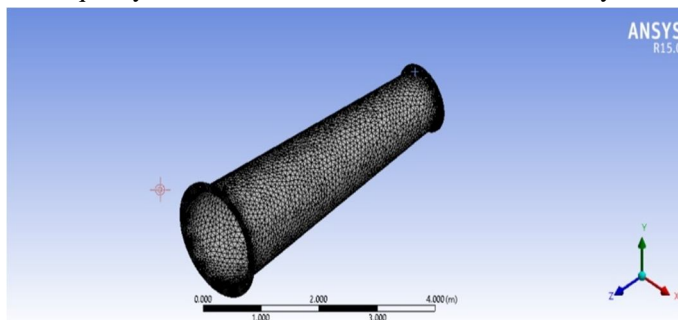

Fig. No 3: Meshed model of segment V of chimney

### VIII. INTRODUCTION TO FLAPPERS

Flappers is the metal material with reducing cross section of area. This reducing cross sectional area increases the pressure energy of the outgoing gases into kinetic energy. Due to increase in velocity of the gases, a turbulent flow is formed and due to this the gas does not stick to the chimney surface. Instead, this gas is flown upwards and outside the chimney. Hence we can reduce the fouling. In our project, we have attached flappers in the second section of the chimney. In our project, we have attached the flappers at different angles ranging from 10°, 12° and 15° and got the results. We did the comparison of various angles and the respective results and computed them with various softwares like ANSYS and CATIA.

The flappers in are used to reduce the fouling effect at different angles. CAD model of flappers is shown in fig 4, 5, 6.

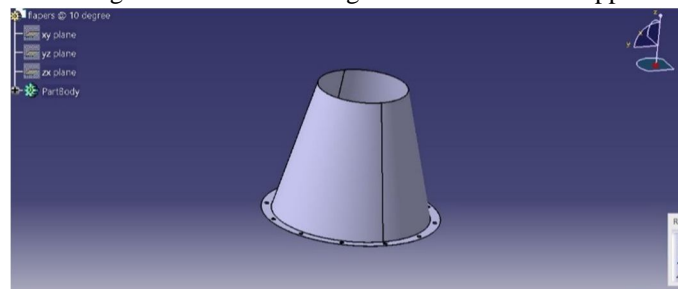

Fig. No 4: Flapper at angle 10°

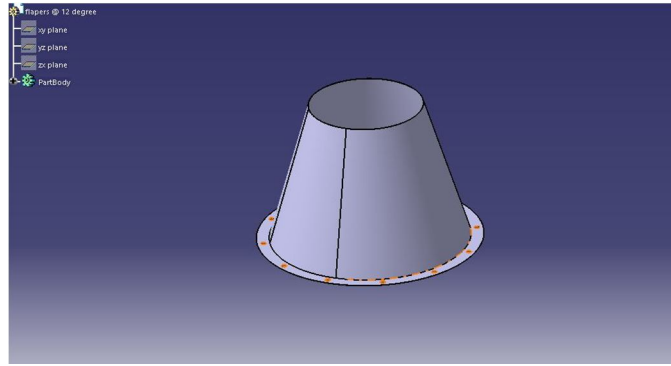

Fig. No 5: Flapper at angle 12°

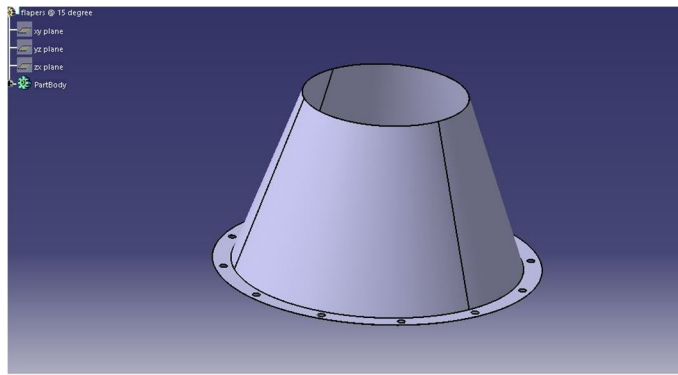

Fig. No 6 : Flapper at angle 15°

CAD model of flappers inserted in segment II of chimney is shown in fig 7, 8, 9.

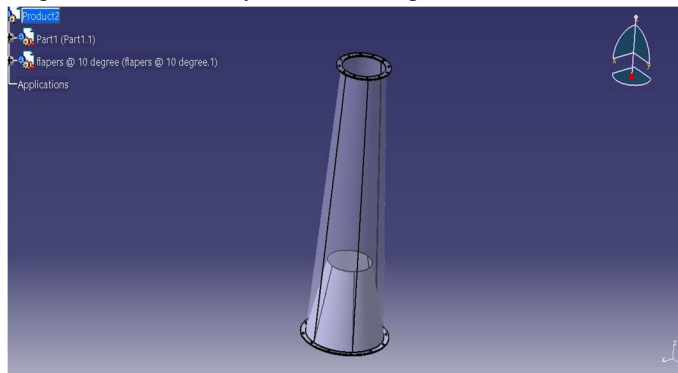

Fig. No 7 : Chimney segment II with Flapper at 10°

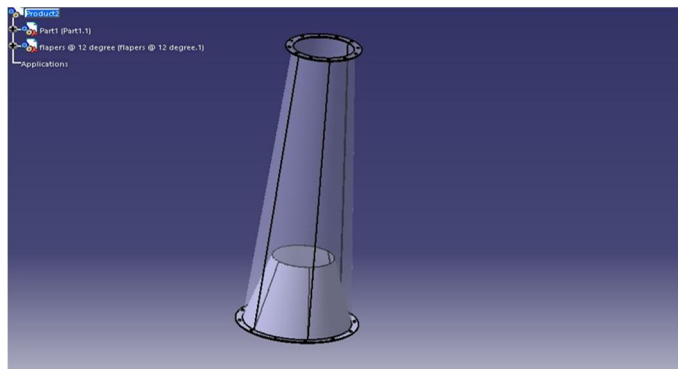

Fig. No 8 : Chimney segment II with Flapper at 12°

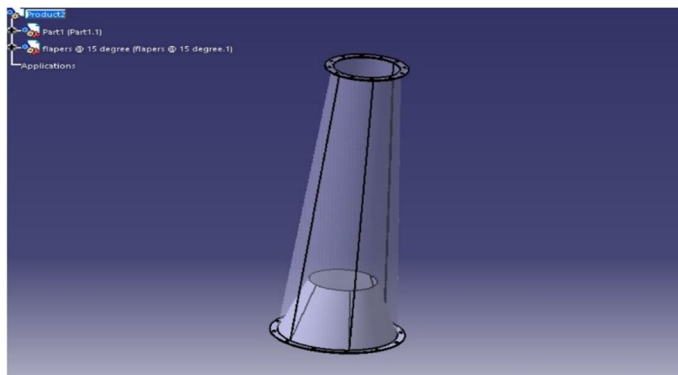

Fig. No 9: Chimney segment II with Flapper at 15°

### IX. DESIGN CONSIDERATIONS AND OPTIMIZATION OF EXISTING DESIGN AND MODIFIED DESIGN

In the designing of the exchanger following factors were put to consideration.

- 1) The surface has to be the most efficient and suitable.
- 2) The design has to consider the fouling effect of the flue gases.
- 3) The design has to allow for quick maintenance without interfering with the boiler operations.
- 4) The ducting design has to conform to the boiler chimney design.

Based on the above points, flapper provided at various angles in chimney convergent duct to check the velocity increase of flue gases in chimney area.

#### A. Change In Velocity of Existing Model And Modified Model

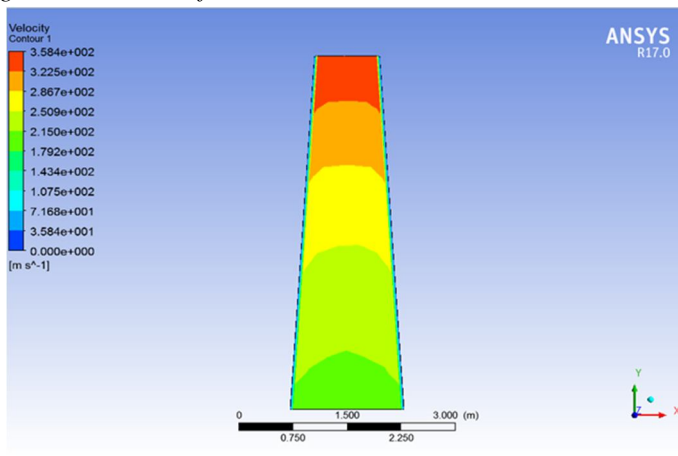

Fig. No 10 : Velocity obtained in without modification.

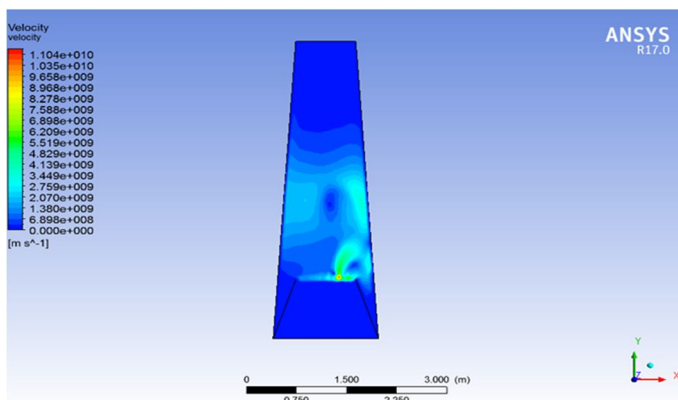

Fig. No 11 : Velocity obtained in with modification.

**B. Change In Pressure Of Existing Model And Modified Model**

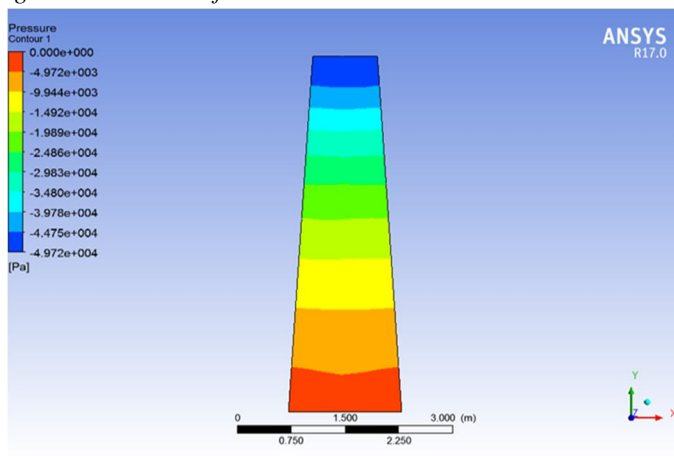

Fig. No 12: Pressure obtained in without modification.

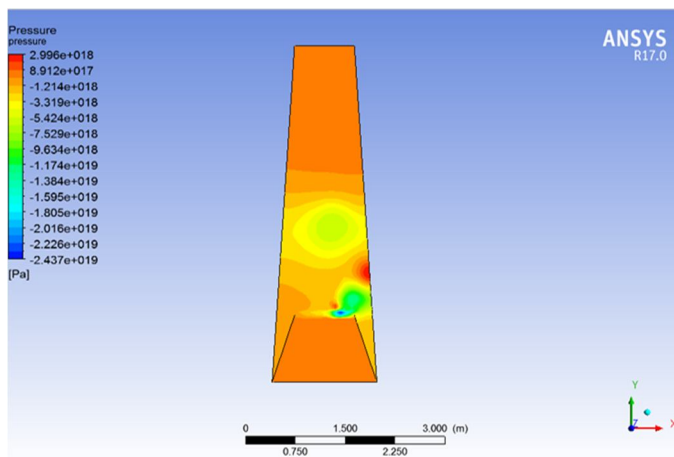

Fig. No 13: Pressure obtained in with modification.

**X. RESULTS**

From above modification we have use convergent on the diverse aspects of the operation of boiler efficiently. In upcoming years to come Efficient operation of boiler is likely to play a very big role in following years, Industries all over the world are going through increased and powerful competition and increased automation of plants. To get away with this challenge, it is clearer by this paper. By using this technology, we have obtained change in velocity and pressure. In other word we can say that, velocity increases and pressure decreases due to modification. The difference between velocity and pressure of existing and modified design is as shown below graph.

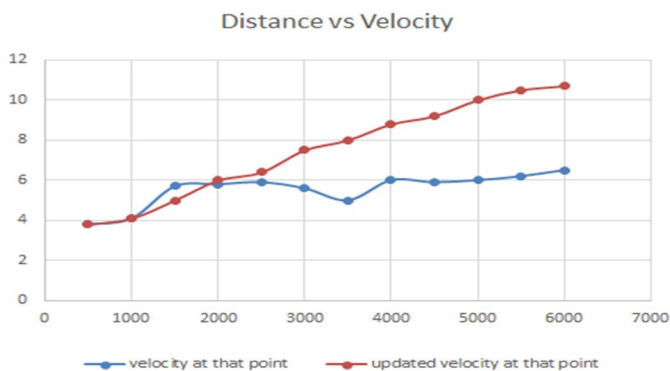

Fig. No 14 : Graph 1- Distance vs Velocity.

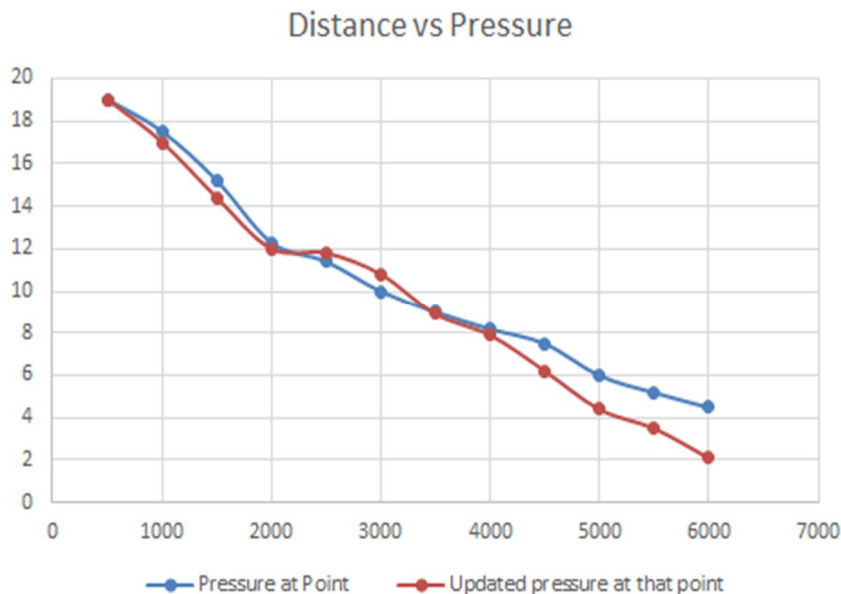

Fig. No 15 : Graph - Distance vs Pressure.

### XI. CONCLUSION

- A. The objective of this project was completion and testing of boiler chimney heat recovery heat exchanger system that could be used to recover heat lost through flue gases and reduces the effects of fouling.
- B. Design calculation with specified working parameters in order to reduce the fouling on boiler chimney surface were validated and implemented successfully.
- C. Attempts were made to reduce fouling by introducing flappers in the fifth section of the chimney. Flappers were installed at various angles like 10°, 12°, 15° and analysis is done on the results by comparing all of them.
- D. Analysis results showed that, the flappers installed at 15° is the best choice to reduce soot formation i.e., fouling which eventually increases the efficiency of the chimney and also the life of chimney.
- E. The effects of pressure and velocities of flue gases on the boiler chimney surface are analyzed through finite element method, the results of which were validated with the actual with satisfactory results.

### XII. FUTURE SCOPE

- A. The exchanger core plate spacing should be increased to improve on air flow.
- B. An allowance for expansion of the plates should be provided at the ends of the plates.
- C. The height of segment should be optimized, to increase the time for the flue gases to exchange heat with air.
- D. Similar work can be done different heat exchanger surface which are affected by fouling or clogging on the heat transfer surface.
- E. In this project Finite element analysis method were used to check the effect of pressure and velocities of flue gases due to design modifications. Computational Fluid dynamics can be applied to check the effects of flue gases due to shape optimization performed due to design modifications.

### XIII. ACKNOWLEDGMENT

The author is indeed a great pleasure and moment of immense satisfaction. I take the opportunity to thanks those who gave us their indebted assistance. I wish to extend my cordial gratitude with profound thanks to our internal guide Prof. R. K. Nanwatkar. It was his inspiration and encouragement which helped us in completing my work. I am also thankful to Prof. S. M. Jadhav, PG Co-ordinator for his overwhelming support and invaluable guidance. My sincere thanks and deep gratitude to Head of Department, Prof. D. H. Burande and other faculty members. At last but not least I express my sincere thanks to the Institute's Principal Dr. Y. P. Reddy, for providing us infrastructure and technical environment.

## REFERANCES

- [1] Ulrich Kleinhansa, Christoph Wielanda, Flemming J. Frandsenc, Hartmut Spliethoffa,b in ELSAVIER journal of Progress in Energy and Combustion Science, in paper entitled(4 February 2018) , “Ash formation and deposition in coal and biomass fired combustion systems: Progress and challenges in the field of ash particle sticking and rebound behavior”.
- [2] Akash Singh, Vivek Sharma, Siddhant Mittal , Gopesh Pandey, Deepa Mudgal, Pallav Gupta in Springer International Journal of Industrial Chemistry (2018) in paper entitled, “An overview of problems and solutions for components subjected to freside of boilers”.
- [3] Ming-Jia Li, Song-Zhen Tang, Fei-long Wang, Qin-Xin Zhao, Wen-Quan Tao, in ELSEVIER journal, (2017) titled, “Gas-side fouling, erosion and corrosion of heat exchangers for middle/low temperature waste heat utilization: A review on simulation and experiment”.
- [4] Sagar Kafle a, Seung Hee Euh a, Lahoon Cho a, Yun Seong Nam a, Kwang Cheol Oh a, Yun Sung Choi a, c, Jae-Heun Oh c, Dae Hyun Kim a, in ELSEVIER Energy Journal, (2017) “Tar fouling reduction in wood pellet boiler using additives and study the effects of additives on the characteristics of pellets”.
- [5] R. K. Mishra, in Springer journal technical article, “Fouling and Corrosion in an Aero Gas Turbine Compressor”, (2015).
- [6] Suhas R Bamrotwar, Dr. V.S.Deshpande, in journal (2014) IOSR-JMCE, named “Root Cause Analysis and Economic Implication of Boiler Tube Failures in 210 MW Thermal Power Plant”.
- [7] K.T. Ajayi and A. A. Akande, in JETEAS (2012) paper published “Effect of Fouling on Heat Transfer Surfaces in Boilers”.
- [8] Kilkovský B, Turek V, Jegla Z. and Stehlík P, in 8th International Conference on Heat Transfer, Fluid Mechanics and Thermodynamics 11 – 13 July 2011, in paper published “Aspects Of Fouling In Case Of Heat Exchangers With Polluted Gas”.
- [9] Mostafa M. Awad Mansoura University, Faculty of Engineering, Mech. Power Eng. Dept., Egypt(2011), in “Fouling of Heat Transfer Surfaces”.
- [10] Panayiotis Andreou, in his master thesis on “Behavior, Analysis and Design ofSteel Chimneys” (Oct 2011).
- [11] Aleksandar M. Simonovic, Slobodan N. Stupa, Ognjen M. Pekovic, in FME Transactions (2008) 36, 119-125, in paper published, “Stress Distribution as a Cause of Industrial Steel Chimney Root Section Failure”.
- [12] Mathew A. Eaton in 15th North American Waste to Energy Conference May 21-23, 2007 “Analysis of Boiler Fouling and Boiler Cleaning Methods at the Commerce Refuse-To-Energy Facility”.
- [13] K B MCINTYRE, Proc S Afr Sug Technol Ass (2002), “A Review of the Common Causes of Boiler Failure in the Sugar Industry”.
- [14] Yimin Zeng, Kaiyang Li, Robin Hughes and Jing-Li Luo, in I&EC Research journal in paper, (2018) “Corrosion Mechanisms and Materials Selection for the Construction of Flue Gas Component in Advanced Heat and Power Systems”.



10.22214/IJRASET



45.98



IMPACT FACTOR:  
7.129



IMPACT FACTOR:  
7.429



# INTERNATIONAL JOURNAL FOR RESEARCH

IN APPLIED SCIENCE & ENGINEERING TECHNOLOGY

Call : 08813907089  (24\*7 Support on Whatsapp)