



iJRASET

International Journal For Research in
Applied Science and Engineering Technology



INTERNATIONAL JOURNAL FOR RESEARCH

IN APPLIED SCIENCE & ENGINEERING TECHNOLOGY

Volume: 7 Issue: XI Month of publication: November 2019

DOI: <http://doi.org/10.22214/ijraset.2019.11153>

www.ijraset.com

Call:  08813907089

E-mail ID: ijraset@gmail.com

Smart Security and Intrusion Prevention System

Prerna Bhatnagar¹, Vasu Gupta², Sumit Chauhan³, Mr. Sandeep Sharma⁴

GGSIPO, BPIT, Delhi, India

Abstract: *Personal security and privacy are two of the big concerns in today's world and thus in this new era of technologically advanced world smart solutions are what we are looking for. Presented is a smart security and intrusion prevention system which once installed in homes or any place that needs to be secure abstains any intrusion and helps the authority to keep a check on any activity that might be a threat by monitoring movement around the port using PIR sensors that on detecting movement captures and sends an image of the intruder along with an intrusion alert message and alarm.*

Keywords: *Security system, intrusion prevention, PIR sensors, email alert, SMTP*

I. INTRODUCTION

In the presented technology PIR sensors are used which provides continuous monitoring and surveillance. These sensors are operated upon by a microcontroller namely Arduino. The PIR Controller detects heat signatures along with an IR sensor that detects movement and they work together to detect motion. On detection of movement, the system captures an image of the intruder and sends it to the authorized person along with a system-generated message of intrusion alert.

The whole system is an effective low-cost intrusion prevention system and can be easily installed anywhere according to space and purpose further sensors can be varied in type and number to make it a versatile product with various applications.

The microcontroller and sensors used are low cost. the whole system is versatile and easy to install anywhere and user-friendly.

The paper is organized as follows. Section II comprises of Literature Review, Section III comprises of the proposed system and the technologies main features and components. Section IV shows the assembly and configuration of the system.

II. LITERATURE REVIEW

This automated technology may provide an effective and low-cost user-friendly solution for all kinds of security purposes where security threats are increasing day by day. The PIR and IR sensors are highly effective, reliable and compact and hence can be used to detect any kind of unauthorized intrusion or security threat. Moreover, these sensors can be replaced with more accurate sensors or a sensor that suits best the environment where the system is being installed to detect motion and set the security alert on.

The microcontroller used namely Arduino is very versatile and efficient and offers various source inputs and outputs that can be used to bring together this system. It comprises the use of Internet Of Things and has various applications as in Jail Security System, Bank Security, Military, homes, secure document housing, etc This system can be installed anywhere with direct access to the concerned authority singular or plural. Incidences of jailbreaks, robberies at homes, document larceny are a very common but serious matter of concern.

This leads to loss of valuable things and information, might even be a threat to national security or someone's life. Most security systems are capable of only sending an alert or locking the port, with the help of several sensors and cameras the system provides automatic and more accurate detection of threat along with an image of the intruder. As manpower is becoming more and more expensive and it might not be feasible to hire manpower for security purposes. Intelligent systems are being designed to automate work and thus making it more feasible and reliable. Machines can be automated and heavily relied upon when it comes to security and intrusion threat detection. The proposed system is all automated and requires minimal human intervention with only reliability on authorized personnel.

The technology Uses Passive Infrared Sensors and Infrared sensors to detect motion that is basically human. PIR works on the principle of detecting heat signatures to detect motion triggered by human intervention.

PIR is compact in size, highly reliable and inexpensive and hence is used in various small scale applications.

The sensors actively detect any motion and send a high voltage input to the Arduino input port. The microcontroller then processes the high input data and runs the code further.

The IR sensor detects motion by sensing the infrared rays that are emitted by the LED. the LED emits infrared rays of a fixed magnitude which are then detected by a photodiode that is sensitive to this set wavelength of rays. As motion is set off as there incurs a change in the magnitude of this infrared ray is registered by the sensor and it sets off.

III. PROPOSED SYSTEM

The general structure of the Smart Security and Intrusion Prevention system is rather simple. It consists of a main microcontroller Arduino board, a PIR sensor to detect heat signatures and an IR sensor to detect motion. The sensors are attached to the Arduino board which is attached to a power source and a computer. Also, a buzzer is attached to the board which is set off when an intrusion is incurred. The schematic of the connections of the PIR sensors and the IR sensors areas in the below figure.

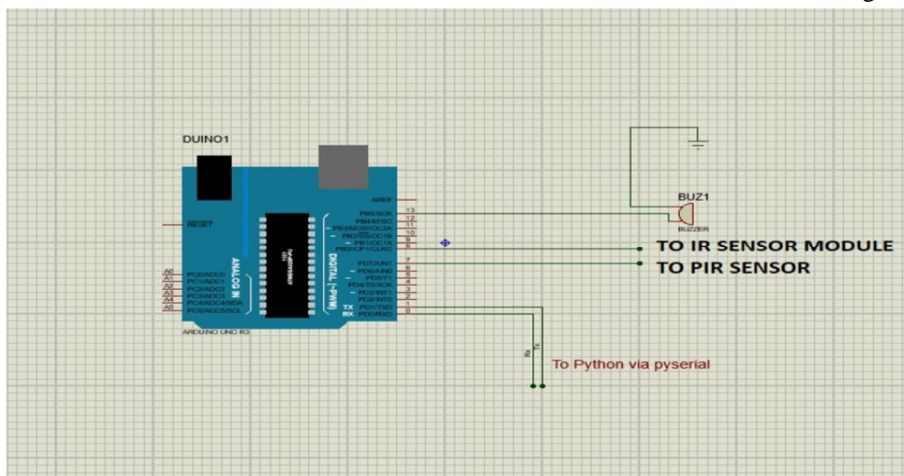

Fig 1. Schematic diagram of the system

A. Software Design of the System

As soon as an intrusion is detected by the PIR or the IR sensors the sensor controller sends a digital high signal to the Arduino and this signal is then received and processed by the microcontroller.

Arduino is programmed to run a set of commands in order to first take a picture of the intruder through the system camera and then initiate the Simple Mail Transfer Protocol to send an email alert stating “INTRUSION DETECTED” along with the image captured by the camera.

B. Flowchart of the System

The system is initiated when intrusion is detected by the sensors.

The sensors send a high output to Arduino which further processes the signal and runs a set of commands that triggers the system camera to click a picture of the intruder and further sends a system-generated intrusion alert along with the captured image.

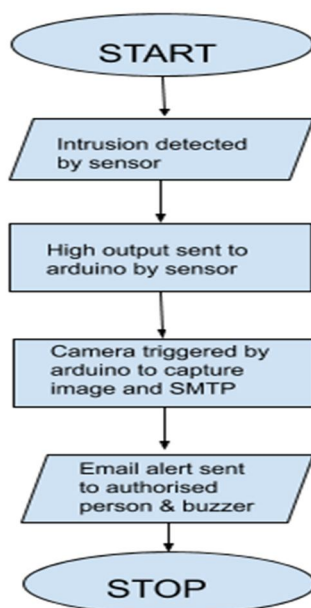

Fig 2. Flowchart of smart security and intrusion prevention system

IV. COMPONENTS USED

A. PIR Sensor

PIR sensors are widely used to detect motion or a heat signature. The PIR sensor or Pyroelectric sensor works on the principle of detection of intensity of infrared rays. It is comprised of two photoelectric diodes which are connected to each other in order to keep a track of the equivalent infrared ray intensity, when there is motion the intensity of infrared waves differs in the two photodiodes as when one registers a change the output will swing high or low and this is registered by the controller chip which further converts the IR waves into analog signal for comparison.

Thus when motion is sensed the PIR sensor catches a difference in the intensity of the infrared rays and triggers a high voltage output.

B. IR Sensor

The IR sensor is an infrared ray sensor that basically senses the change in infrared rays in a system. It consists of an LED that emits infrared rays that fall upon a photoelectric diode that further senses the IR rays. When an intrusion to the path of these IR waves is detected the output goes high and a signal is sent.

V. CONCLUSION

This paper presents the design and the implementation of a smart security and intrusion prevention system. The system has a friendly user interface and employs some methods to reduce power consumption. The system is easy to install and use. The system is low cost, low power consumption, and an easily operable system. The system can lightly be expanded to other applications.

VI. FUTURE SCOPE

This smart security and intrusion prevention system has various uses in different niches for security purposes-

- A. Various sensors can be used in competence with the environment in order to detect and avoid security threats.
- B. This system can be installed on various vaults in order to ensure safety and avoid the breach
- C. It can further be developed to support face recognition and give access to only authorized personnel

REFERENCE

- [1] Pooja Dahiya (student), Neha (Student) "IoT based Home Alert System using Wi-Fi and Cloud Technologies" National Conference on Product Design (NCPD 2016), July 2016.
- [2] Safa.H, Sakthi Priyanka.N, Vikkashini Gokul Priya.S, Vishnupriya.S, Boobalan.T "IOT based Theft Preemption and Security System" International Journal of Innovative Research in Science, Engineering and Technology, An ISO 3297: 2007 Certified Organization.
- [3] M.Sangeetha, C.Udhayanila, G.Gayathri, N.Rakshana "Smart Home Control System by the Internet of Things Based on WIFI Module", Smart Home Control System by the Internet of Things Based on WIFI Module, An ISO 3297: 2007 Certified Organization.
- [4] Vinod Choudhary, Aniket Parab, Satyajit Bhapkar, Neetesh Jha, Ms. Medha Kulkarni "Design and Implementation of Wi-Fi-based International Journal of Scientific Research in Science, Engineering and Technology (ijraset.com) 48 Smart Home System", International Journal Of Engineering And Computer Science ISSN:2319- 7242, Volume – 5 Issue -02 February, 2016 Page No. 15852-15855.
- [5] Swati Tiwari, Rahul Gedam "A Review Paper on Home Automation System Based on Internet of Things Technology", International Research Journal of Engineering and Technology (IRJET), e-ISSN: 2395 -0056, p-ISSN: 2395-0072.
- [6] Shaik Anwar, D. Kishore "IOT based Smart Home Security System with Alert and Door Access Control using Smart Phone", International Journal of Engineering Research & Technology (IJERT) ISSN: 2278-0181 Vol. 5 Issue 12, December-2016



10.22214/IJRASET



45.98



IMPACT FACTOR:
7.129



IMPACT FACTOR:
7.429



INTERNATIONAL JOURNAL FOR RESEARCH

IN APPLIED SCIENCE & ENGINEERING TECHNOLOGY

Call : 08813907089  (24*7 Support on Whatsapp)